

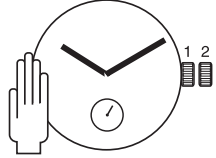

10 ½''' ETA 7001

CT 7001 FDE 289015 06 11.09.2014

10 ½''' Ø 23,30 mm



Hauteur sur mouvement	Höhe auf Werk	Movement height	2,50 mm
Réserve de marche	Gangreserve	Running time	42 h
Nombre de rubis	Anzahl Rubine	Number of jewels	17
Angle de levée du balancier	Hebungswinkel der Unruh	Angle lift of balance	50°
Fréquence	Frequenz	Frequency	21'600 A/h

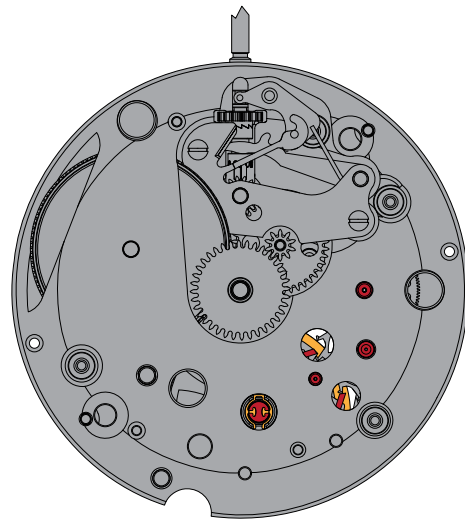
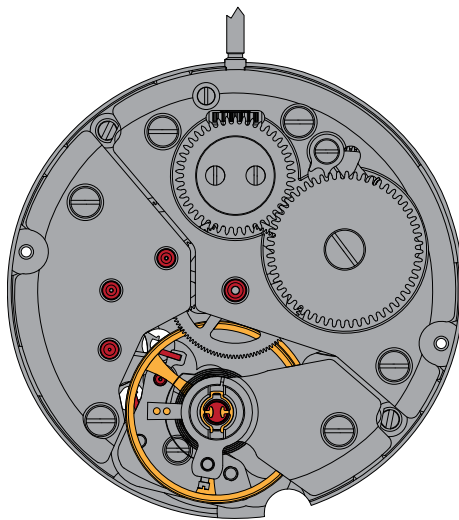

Les travaux de réparation et de révision ne doivent être effectués que par du personnel dûment formé.
Reparatur- und Revisionsarbeiten dürfen nur von ausgebildetem Fachpersonal ausgeführt werden.
The repair and reconditioning work must only be performed by properly trained personnel.



Informations générales



Avant de démarrer les travaux, veuillez svp étudier attentivement cette "Communication technique".



La protection des yeux est obligatoire pour toutes les interventions / tous les travaux sur le mouvement!



ETA SA décline toute responsabilité en cas de dommages du non respect de cette "Communication technique".

Exigences en matière de protection de l'environnement



Les dispositions légales en matière de traitement et d'élimination des déchets doivent être respectées lors de toutes les interventions / tous les travaux sur les mouvements!

En particulier, les produits de graissage et de nettoyage néfastes pour l'environnement doivent être éliminés selon les règles!



Les **substances de nature à polluer l'eau** doivent être entreposées, transportées, récupérées et éliminées dans des récipients adéquats.

Elles ne doivent en aucun cas polluer le sol ou être évacuées dans les réseaux de canalisation!

Explication des symboles



Attention! Risque de dégât matériel!

Ci-après quelques instructions à suivre obligatoirement pour éviter tout dégât matériel!

Allgemeine Informationen



Diese "Technische Mitteilung" ist **vor** dem Beginn der Arbeiten genauestens zu studieren.



Für sämtliche Arbeiten am und mit dem Uhrwerk ist ein Augenschutz obligatorisch!



Für Schäden, welche durch Nichtbeachtung dieser "Technischen Mitteilung" entstehen, haftet die ETA SA nicht.

Umweltschutz-Vorschriften



Bei allen Arbeiten am und mit dem Uhrwerk sind die gesetzlichen Vorschriften zur ordnungsgemässen Verwertung und Beseitigung der Abfälle einzuhalten!

Insbesondere sind umweltgefährdende Schmier- und Reinigungsmittel ordnungsgemäss zu entsorgen!



Wassergefährdende Stoffe müssen in geeigneten Behältern aufbewahrt, transportiert, aufgefangen und entsorgt werden.

Diese dürfen nicht den Boden belasten oder in die Kanalisation gelangen!

Symbolerklärung



Achtung! Gefahr von Sachschäden!

Hier folgen wichtige Hinweise, die zur Vermeidung von Sachschäden unbedingt beachtet werden müssen!

General information



Before starting work, please study this "Technical communication" carefully.



Eye protection is obligatory for all operations / work on the movement!



ETA SA disclaims any liability in case of damage arising from failure to observe this "Technical communication".

Environmental protection requirements



The legal provisions relating to waste handling and disposal must be observed in all operations / work on the movements!

In particular, lubricating and cleaning products harmful to the environment must be disposed of in accordance with the rules!



Substances prone to cause water pollution must be stored, transported, collected and disposed of in appropriate vessels.

Under no circumstances must they pollute the soil or be poured into sewage systems!

Explanation of symbols



Caution! Risk of material damage!

Below are some obligatory instructions for preventing any material damage!

Liste des fournitures - Bestandteilliste - List of components

Pos	No Nr No	No Nr CS No	Numéro d'article Artikelnummer Article number	Liste des fournitures	Bestandteilliste	List of components
1	100	10.020.06	Var	Platine, montée	Werkplatte, montiert	Main plate, assembled
1-1	144	10.300.00	7613226002043	Fixateur de cadran	Zifferblatthalter	Dial fasteners
1-2	3025	70.531.00	7613226021617	Amortisseur empierré de balancier, à chasser, à portée, dessous INCABLOC	Stosssicherung mit Stein, für Unruh, zum Einpressen, mit Auflage, unten INCABLOC	Jewelled shock-absorber, for balance, shouldered, to press in, bottom INCABLOC
2	407	31.121.00	7613226034341	Pignon coulant	Kupplungstrieb	Sliding pinion
3	410	31.120.00	7613226038899	Pignon de remontoir	Aufzugtrieb	Winding pinion
4	401	51.010.00	7613226050372	Tige de remontoir	Aufzugwelle	Winding stem
5	443	51.080.00	7613226019362	Tirette	Winkelhebel	Setting lever
6	435	51.050.00	7613226054912	Bascule de pignon coulant	Kupplungstriebhebel	Yoke
7	440	61.100.00	7613226052796	Ressort de bascule	Kupplungshebelfeder	Yoke spring
8	450	31.100.00	7613226007932	Renvoi	Zeigerstellrad	Setting wheel
9	260	31.041.00	7613226021020	Roue de minuterie	Wechselrad	Minute wheel
10	445	51.090.00	7613226000100	Sautoir de tirette	Winkelhebelaste	Setting lever jumper
11	705	30.040.00	7613226045576	Roue d'échappement	Hemmungsrads	Escape wheel
12	220	30.027.06	Var	Roue de seconde, montée	Sekundenrad, montiert	Second wheel, assembled
13	210	30.025.00	7613226031784	Roue moyenne	Kleinbodenrad	Third wheel
14	201	30.015.00	7613226048225	Roue de centre	Minutenrad	Centre wheel
15	110	10.048.07	Var	Pont de rouage, empierré	Räderwerkbrücke, mit Steinen	Train wheel bridge, jewelled
16	180/1	20.010.00	7613226033573	Barillet complet de mouvement	Federhaus vollständig für Grundwerk	Movement barrel complete
17	105	10.041.07	Var	Pont de barillet, empierré	Federhausbrücke, mit Stein	Barrel bridge, jewelled
18	420	31.023.00	Var	Roue de couronne	Kronrad	Crown wheel
19	423	81.136.00	Var	Noyau de roue de couronne	Kronradkern	Crown wheel core
20	425	51.120.00	7613226039230	Cliquet	Klinke	Click
21	430	61.080.00	7613226003040	Ressort de cliquet	Klinkenfeder	Click spring
22	415	31.020.00	Var	Rochet	Sperrrad	Ratchet wheel
23	710	40.010.06	7613226056251	Ancre, montée	Anker, montiert	Pallet fork, assembled
24	125	10.057.07	Var	Pont d'ancre, empierré	Ankerbrücke, mit Stein	Pallet bridge, jewelled
25	721	40.050.21	7613226056398	Balancier réglé, avec piton, chronomètre	Unruh reguliert, mit Spiralklötzchen, Chronometer	Timed balance regulated, with stud, chronometer
26	121	10.058.06	Var	Pont balancier, monté	Unruh-Brücke, montiert	Balance bridge, assembled
26-1	121/3	10.058.00	Var	Pont balancier	Unruh-Brücke	Balance bridge
26-2	307/1	40.301.06	7613226036895	Raquette sans flèche, monté	Rücker ohne Stiel, montiert	Regulator without pointer, assembled
26-3	375	40.200.00	7613226026438	Porte-piton	Spiralklötzchenträger	Stud support
26-4	3024	70.500.00	7613226037687	Amortisseur empierré de balancier, à chasser, à portée, dessus INCABLOC	Stosssicherung mit Stein, für Unruh, zum Einpressen, mit Auflage, oben INCABLOC	Jewelled shock-absorber, for balance, shouldered, to press in, top INCABLOC
27	240	31.080.00	Var	Chaussée entraîneuse	Mitnehmer-Minutenrohr	Driver cannon pinion
28	250	31.046.00	Var	Roue des heures	Stundenrad	Hour wheel
900	-	88.502.00	Var	Vis spéciale - Pos. 5: Vis de tirette	Spezialschraube - Pos. 5: Schraube für Winkelhebel	Special screw - Pos. 5: Screw for setting lever
901	-	88.542.00	7613226051898	Vis à tête conique - Pos. 10: Vis de sautoir de tirette	Senkschraube - Pos. 10: Schraube für Winkelhebelaste	Countersunk head screw - Pos. 10: Screw for setting lever jumper
902	-	88.502.01	Var	Vis à tête cylindrique - Pos. 15: Vis de pont de rouage - Pos. 17: Vis de pont de barillet - Pos. 26: Vis de pont balancier	Zylinderkopfschraube - Pos. 15: Schraube für Räderwerkbrücke - Pos. 17: Schraube für Federhausbrücke - Pos. 26: Schraube für Unruhbrücke	Cylindrical head screw - Pos. 15: Screw for train wheel bridge - Pos. 17: Screw for barrel bridge - Pos. 26: Screw for balance bridge
903	-	88.542.01	Var	Vis à tête conique - Pos. 19: Vis de noyau de roue de couronne	Senkschraube - Pos. 19: Schraube für Kronradkern	Countersunk head screw - Pos. 19: Screw for crown wheel core
904	-	88.502.02	Var	Vis à tête cylindrique - Pos. 20: Vis de cliquet	Zylinderkopfschraube - Pos. 20: Schraube für Klinke	Cylindrical head screw - Pos. 20: Screw for click
905	-	88.502.03	Var	Vis à tête cylindrique - Pos. 22: Vis de rochet	Zylinderkopfschraube - Pos. 22: Schraube für Sperrad	Cylindrical head screw - Pos. 22: Screw for ratchet wheel
906	-	88.502.04	Var	Vis à tête cylindrique - Pos. 24: Vis de pont d'ancre	Zylinderkopfschraube - Pos. 24: Schraube für Ankerbrücke	Cylindrical head screw - Pos. 24: Screw for pallet bridge

Pos	No Nr No	No Nr CS No	Numéro d'article Artikelnummer Article number	Liste des fournitures	Bestandteilliste	List of components
			Var	Variante	Variante	Variant

L'interchangeabilité et les variantes se trouvent sur ETA ONLINE SHOP (EOS) :

www.eta.ch
→ Support Center
→ Support Center Portal

Die Austauschbarkeit und Varianten finden Sie im ETA ONLINE SHOP (EOS):

www.eta.ch
→ Support Center
→ Support Center Portal

Interchangeability and variants can be found on the ETA ONLINE SHOP (EOS):

www.eta.ch
→ Support Center
→ Support Center Portal

Fournitures - Bestandteile - Materials

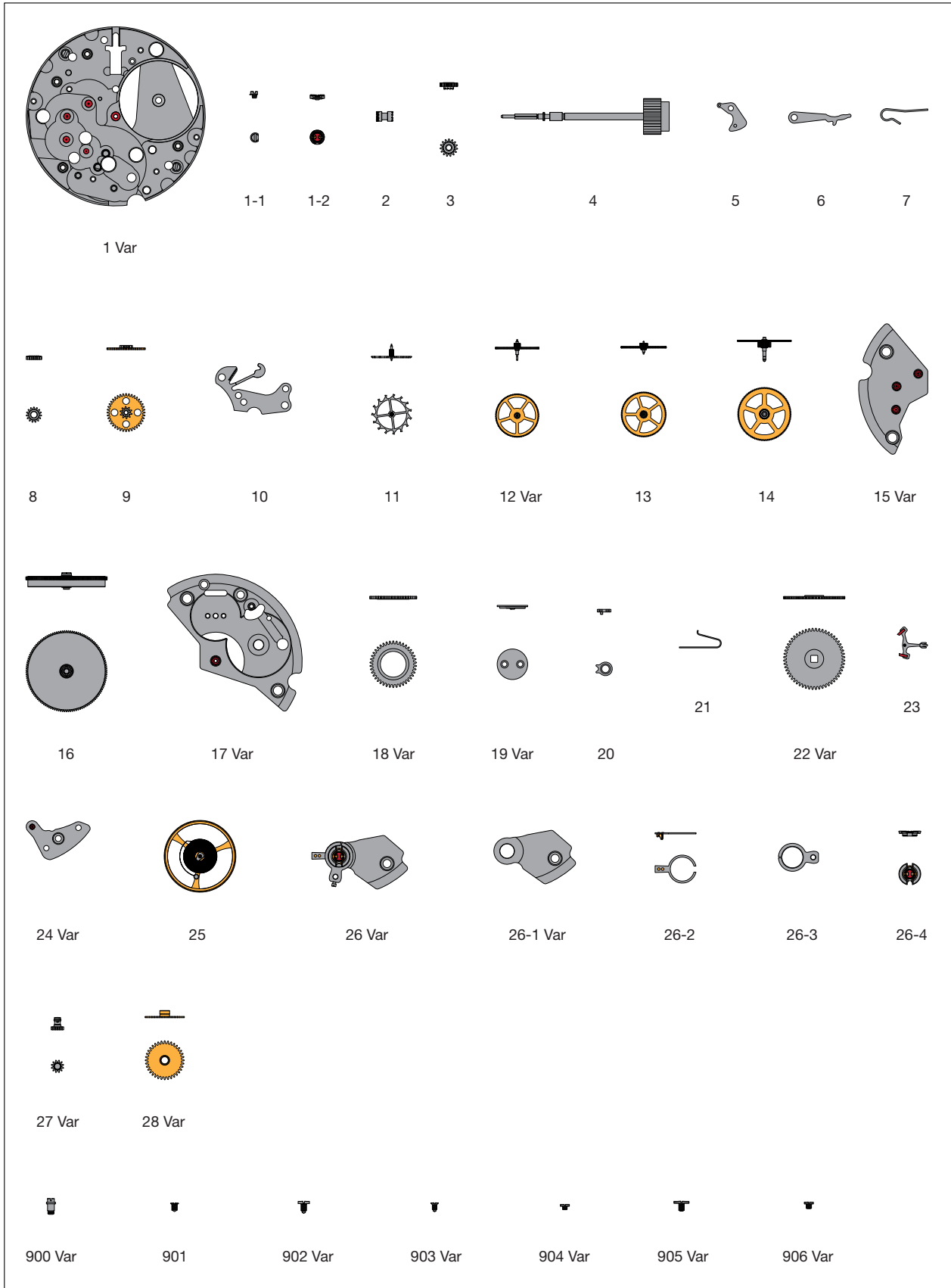

Ordre d'assemblage - Montagereihenfolge - Order of assembly:
 Mécanisme de mise à l'heure - Zeigerwerkmechanismus - Handsetting mechanism

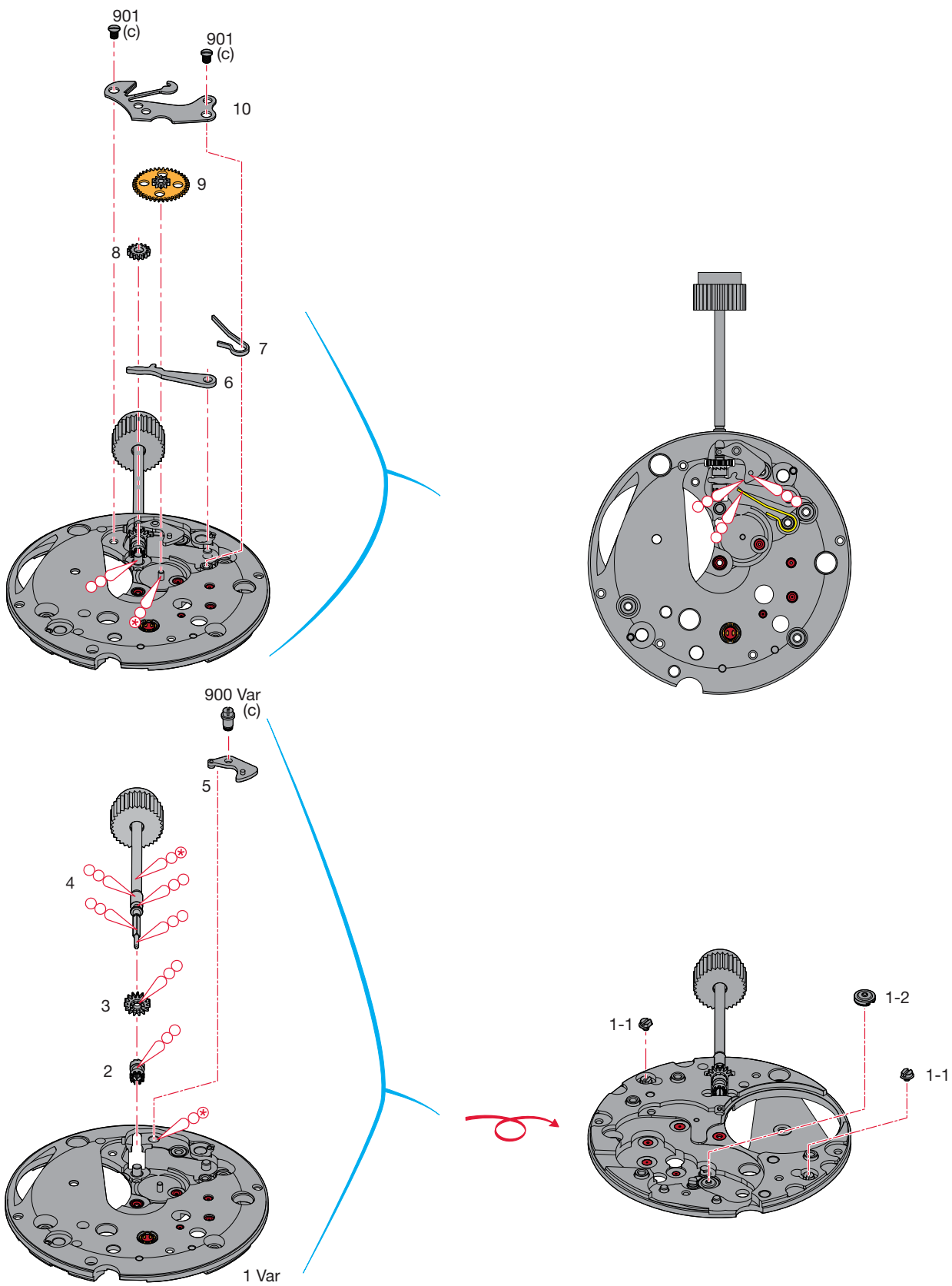

Montage du mécanisme de mise à l'heure

(Liste des fournitures par ordre d'assemblage)

Zusammenstellen des Zeigerwerkmechanismus

(Bestandteilliste in Montager Reihenfolge)

Assembling of the handsetting mechanism

(Parts listed in order of assembly)

1 Var	5	9
2	6	10
3	7	901 (2x)
4	8	

Lubrification - Schmierung - Lubrication

 Huile épaisse ou graisse
 Dickflüssiges Öl oder Fett
 Thick oil or grease

**Moebius
HP-1300**
 ou / oder / or
Moebius D5



 Très faible quantité
 Sehr kleine Menge
 Very small quantity

**Moebius
HP-1300**
 ou / oder / or
Moebius D5

M_L Couple minimum pour dévisser**M_L Minimales Drehmoment zum Lösen****M_L Minimum torque for loosening**

(c) 0,7 Ncm

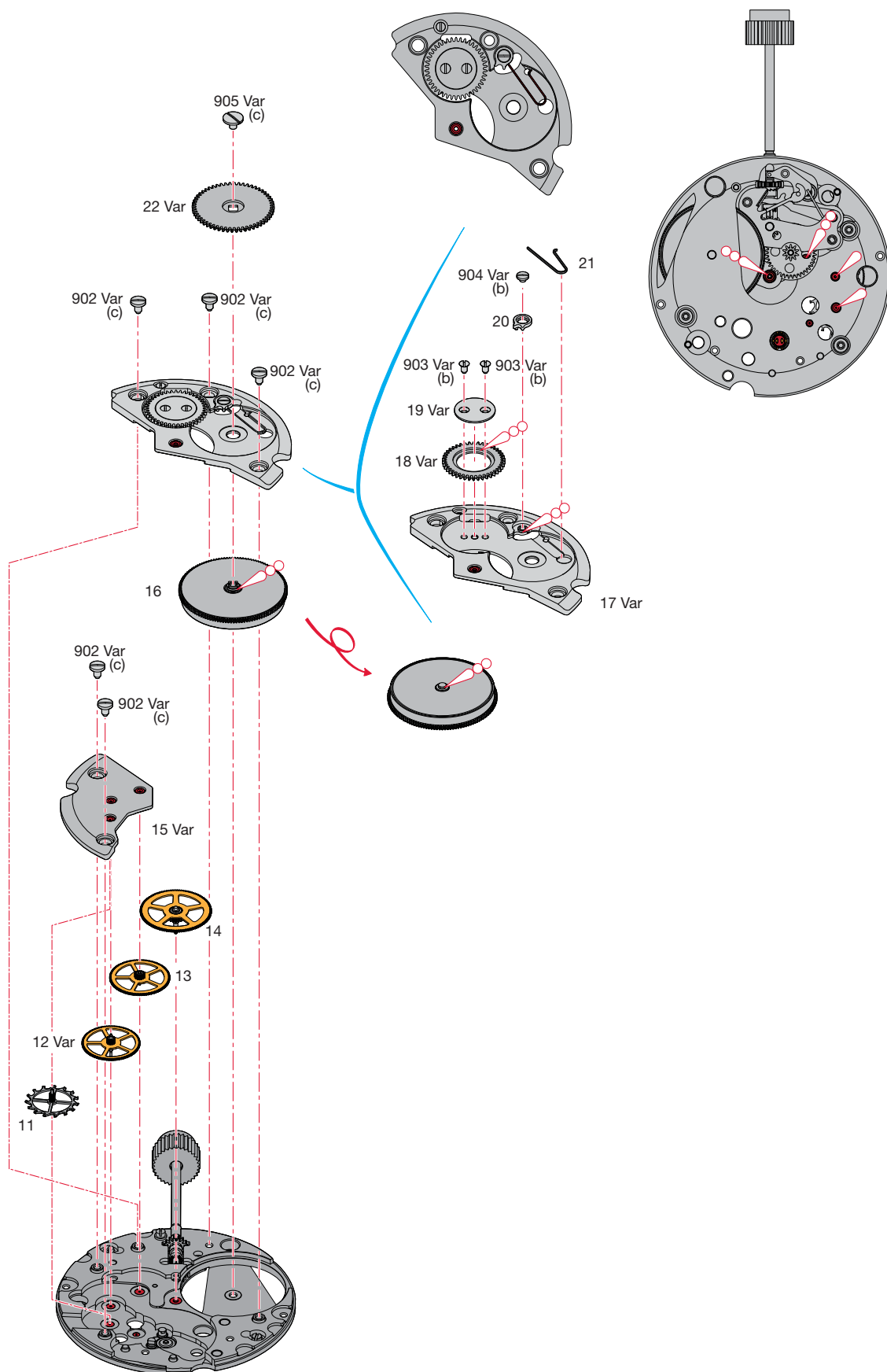
Ordre d'assemblage - Montager Reihenfolge - Order of assembly:
 Mouvement de base - Basiswerk - Basic movement



Montage du mouvement de base

(Liste des fournitures par ordre d'assemblage)

Zusammenstellen des Basiswerkes



(Bestandteilliste in Montager Reihenfolge)

Assembling of the basic movement

(Parts listed in order of assembly)

11	16	904 Var (1x)
12 Var	17 Var	21
13	18 Var	902 Var (3x)
14	19 Var	22 Var
15 Var	903 Var (2x)	905 Var (1x)
902 Var (2x)	20	

Lubrication - Schmierung - Lubrication

	Huile épaisse ou graisse Dickflüssiges Öl oder Fett Thick oil or grease	Moebius HP-1300 ou / oder / or Moebius D5
	Huile fine Dünnflüssiges Öl Fine oil	Moebius 9010

M_L Couple minimum pour dévisser**M_L Minimales Drehmoment zum Lösen****M_L Minimum torque for loosening**

- (b) 0,6 Ncm
- (c) 0,7 Ncm

Ordre d'assemblage - Montagerihenfolge - Order of assembly:
 Mouvement de base - Basiswerk - Basic movement

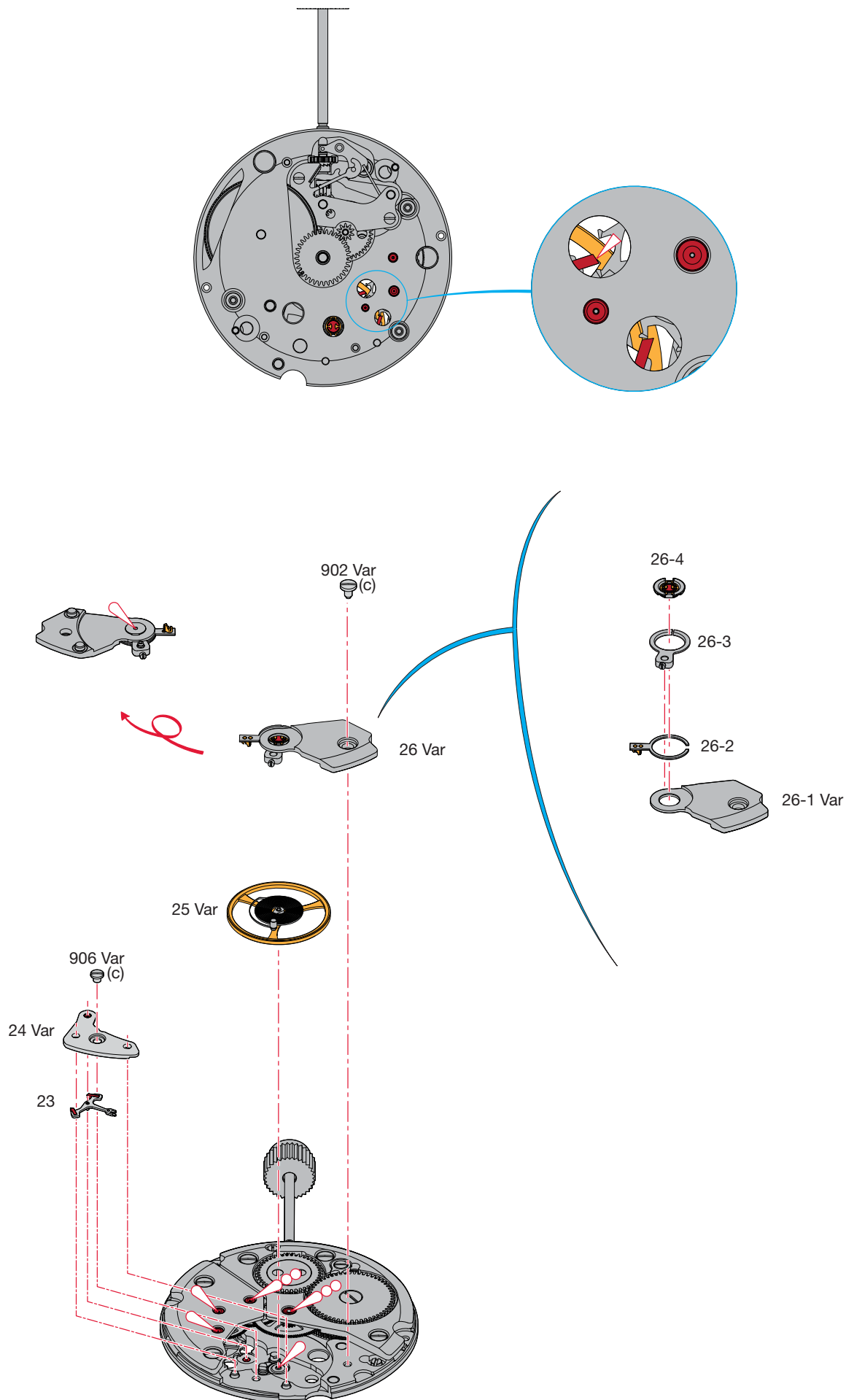

Montage du mouvement de base

(Liste des fournitures par ordre d'assemblage)

Zusammenstellen des Basiswerkes

(Bestandteilliste in Montager Reihenfolge)

Assembling of the basic movement

(Parts listed in order of assembly)

23	25 Var
24 Var	26 Var
906 Var (1x)	902 Var (1x)

Lubrification - Schmierung - Lubrication

Huile épaisse ou graisse
Dickflüssiges Öl oder Fett
Thick oil or grease

**Moebius
HP-1300**
ou / oder / or
Moebius D5



Huile fine
Dünnflüssiges Öl
Fine oil

Moebius 9010



Huile spéciale pour levées
Spezialöl für Hebungssteine
Special oil for pallet stones

Moebius 941
ou / oder / or
Moebius 9415

M_L Couple minimum pour dévisser**M_L Minimales Drehmoment zum Lösen****M_L Minimum torque for loosening**

- (a) 0,25 Ncm
- (c) 0,7 Ncm

Ordre d'assemblage - Montager Reihenfolge - Order of assembly:
Rouage - Räderwerk - Wheel train

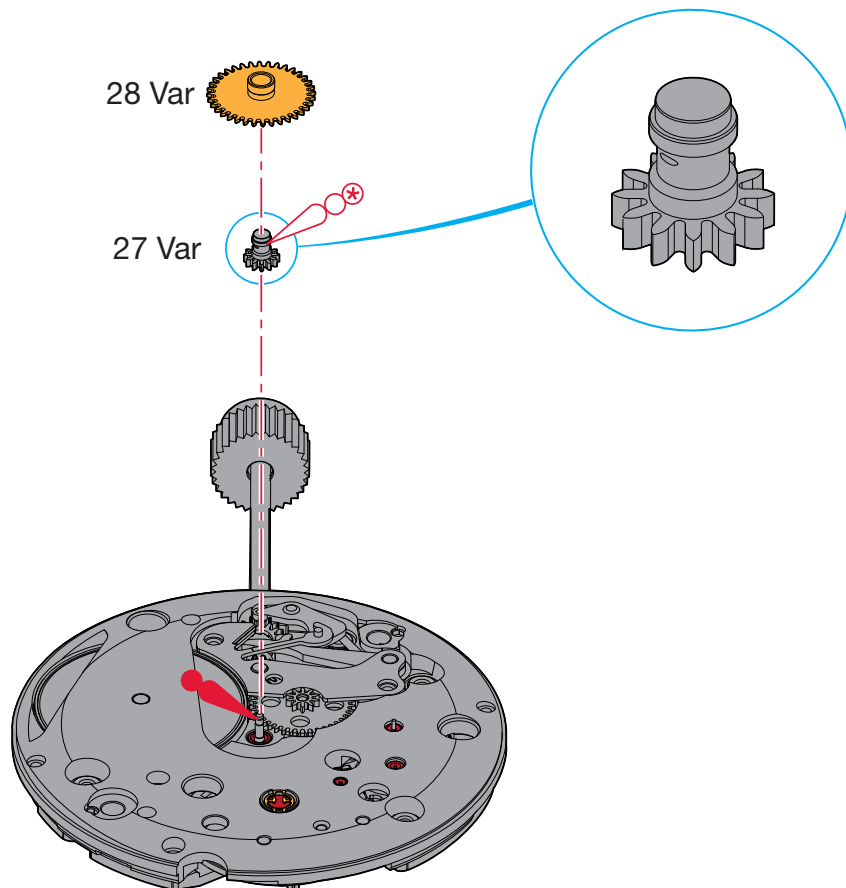

Montage du rouage

(Liste des fournitures par ordre d'assemblage)

Zusammenstellen des Räderwerks

(Bestandteilliste in Montager Reihenfolge)

Assembling of the wheel train

(Parts listed in order of assembly)

27 Var

28 Var

Lubrification - Schmierung - Lubrication

Très faible quantité
Sehr kleine Menge
Very small quantity

**Moebius
HP-1300**
ou / oder / or
Moebius D5



Graisse
Fett
Grease

Moebius 9501
ou / oder / or
Jismaa 124

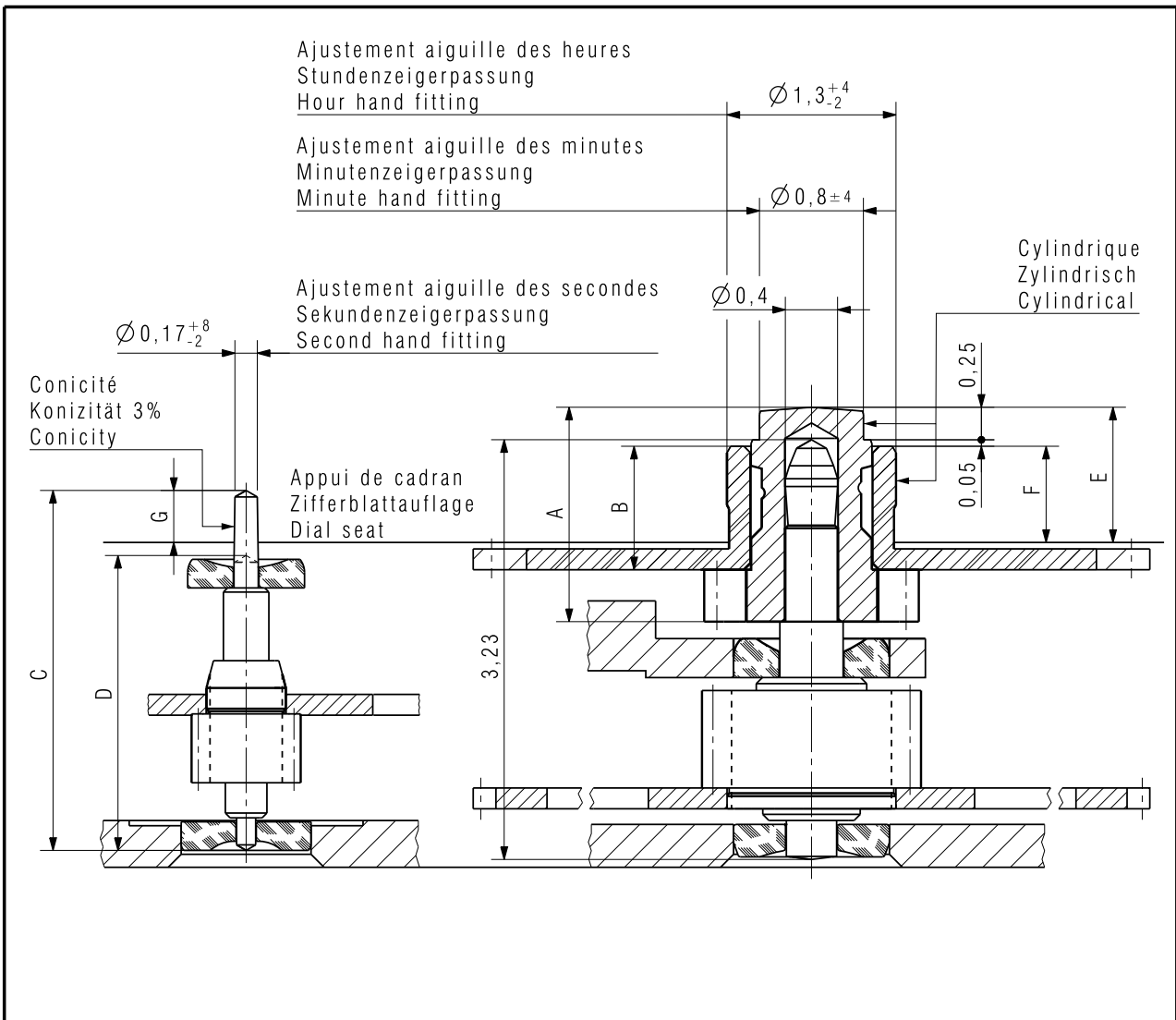

Aiguillage Zeigerwerkhöhe Hand fitting height	Longueur / Länge / Length				Höhe über Zifferblattaufgabe Height over dial seat Dépassement		
	A	B	C	D	E	F	G
1	1,65	0,95	2,77	sans sec. ohne Sek. without sec. 2,27	1,04	0,74	0,40
2 normal	1,80	1,10	2,77		1,19	0,89	0,40
3	1,95	1,25	2,77		1,34	1,04	0,40
4	2,20	1,50	2,77		1,59	1,29	0,40

Kaliber / Calibre / Caliber 7001	Masstab Echelle Scale --		CATIA V5
		Masse in mm Dimensions en mm Dimensions in mm	Tol. 1/1000 mm

AIGUILLAGES ZEIGERWERKHÖHEN HAND FITTING HEIGHTS	Version 04	Revision 00	Blatt Feuille Sheet 01/01
Z0091272			

ETA SA MANUFACTURE HORLOGÈRE SUISSE DEPUIS 1793 A COMPANY OF THE SWATCH GROUP	Ersatz für/En remplacement de/Remplacement for	Klass. ZVACC	KUN
	Aenderung/Modification	Erstellt Etabli Created 07.04.2009 FRL	Geprüft Contrôlé Controlled 13.11.2009 HID
	24551	Freigegeben Libéré Released 13.11.2009 HID	

Nous nous réservons tous les droits sur ce document. Il est comié au destinataire. Il ne peut, sans notre autorisation écrite, être copié, reproduit, communiqué à des tiers.
 Für dieses Dokument behalten wir uns alle Rechte vor. Es ist nur für den Empfänger bestimmt. Ohne unsere schriftliche Bewilligung darf es nicht kopiert, vervielfältigt und Dritten zugänglich gemacht werden.
 We reserve all rights for this document. It is meant for the recipient only and it may not be copied, printed or given to a third person without our written permission.

Cette page est laissée vide
intentionnellement en cas d'impression
au format A3.

Diese Seite wird absichtlich leer
gelassen für den Fall, dass im
A3-Format gedruckt wird.

This page has deliberately been
left blank in case of A3 format
printing.

**Modifications comparées aux versions
précédentes du document****Änderungen gegenüber vorher-
gehenden Dokumentversionen****Modifications compared with previous
document versions**

Version	Date Datum Date	Modification	Änderung	Modification	Page Seite Page
06	11.09.2014	Adaptation variante et numéro GTIN	Anpassung Variante und GTINnr.	Adaptation variant and GTIN number	3-13
05	11.11.2011	Correction ordre des fournitures	Reihenfolge Bestandteile	Order of spare parts correction	3
		Ajout variante sur la liste fourniture	Variante bei Bestandteilliste ergänzt	Addition variant in list of components	3-4
		Modifications montage	Änderungen Montage	Montage modifications	6-13
04	18.11.2009	Suppression des pièces No 224, 5101 et 5102	Teile Nr. 224, 5101 und 5102 entfernt	Remove parts No. 224, 5101 and 5102	2
		Nouveau plan	Neue Zeichnung	New drawing	7
		Nouveau layout	Neues Layout	New layout	1-8
03	02.12.2003	Version de base	Basic Version	Basis version	--

Sous réserve de toutes modifications.

Änderungen vorbehalten.

All modifications reserved.

**Ce document se trouve sur le
Support Center Portal (SCP) :****www.eta.ch**

- Support Center
- Support Center Portal
- Documents techniques

**Dieses Dokument finden Sie im
Support Center Portal (SCP):****www.eta.ch**

- Support Center
- Support Center Portal
- Technische Dokumente

**This document can be found on the
Support Center Portal (SCP):****www.eta.ch**

- Support Center
- Support Center Portal
- Technical Documents



ETA^{SA}
MANUFACTURE HORLOGÈRE SUISSE
DEP. N. 5.1793

SC PRODUCT COMMUNICATION

Bahnhofstrasse 9
2540 Grenchen
Switzerland

Phone +41 (0)32 655 71 11
Fax +41 (0)32 655 71 74

contact@eta.ch
www.eta.ch



10 ½^{'''} ETA 7001

CT 7001 ESI 328464 06 11.09.2014

10 ½^{'''} Ø 23,30 mm

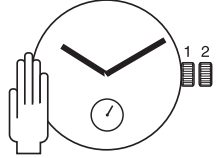

Movement height	Altura sobre máquina	Altezza sopra movimento	2,50 mm
Running time	Reserva de marcha	Riserva di marcia	42 h
Number of jewels	Número de piedras	Numero di pietre	17
Angle lift of balance	Ángulo de alzamiento	Angolo di alzamento	50°
Frequency	Frecuencia	Frequenza	21'600 A/h

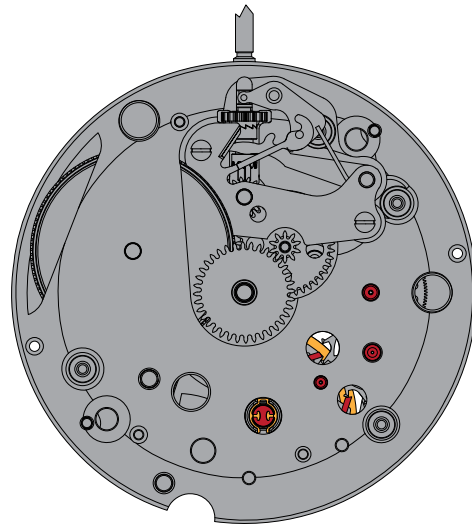
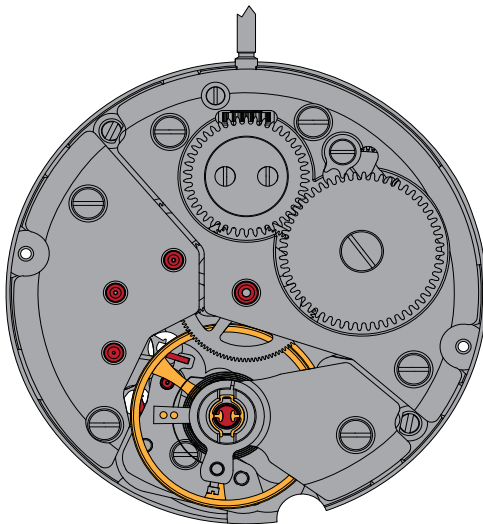

The repair and reconditioning work must only be performed by properly trained personnel.
Las tareas de reparación y revisión sólo deben ser llevadas a cabo por personal debidamente formado.
I lavori di riparazione e di revisione devono essere eseguiti esclusivamente da personale adeguatamente formato.



General information



Before starting work, please study this "Technical communication" carefully.



Eye protection is obligatory for all operations / work on the movement!



ETA SA disclaims any liability in case of damage arising from failure to observe this "Technical communication".

Environmental protection requirements



The legal provisions relating to waste handling and disposal must be observed in all operations / work on the movements!

In particular, lubricating and cleaning products harmful to the environment must be disposed of in accordance with the rules!



Substances prone to cause water pollution must be stored, transported, collected and disposed of in appropriate vessels.

Under no circumstances must they pollute the soil or be poured into sewage systems!

Explanation of symbols



Caution! Risk of material damage!

Below are some obligatory instructions for preventing any material damage!

Información general



Esta "Comunicación técnica" deberá estudiarse muy bien **antes** de comenzar los trabajos.



Es obligatorio utilizar protección ocular para todos los trabajos en y con el reloj.



ETA SA no se hace responsable de los daños provocados como consecuencia de la inobservancia de esta "Comunicación técnica".

Normas de protección medioambiental



Deberá cumplirse la normativa legal relativa al reciclaje y la eliminación correctos de los residuos en todos los trabajos en y con el reloj.

En especial, deberán eliminarse correctamente los productos lubricantes y de limpieza peligrosos para el medio ambiente.



Las sustancias contaminantes del agua deben recogerse, almacenarse, transportarse y eliminarse en recipientes adecuados.

En ningún caso se permitirá que contaminen el suelo o que lleguen a la canalización.

Significado de los símbolos



Atención Peligro de daños materiales

Instrucciones que deberán respetarse necesariamente para evitar daños materiales.

Informazioni generali



Questa "Comunicazione Tecnica" deve essere studiata attentamente **prima** dell'inizio dei lavori.



Per tutti i lavori su e con il movimento dell'orologio è obbligatorio proteggere gli occhi!



ETA SA declina qualunque responsabilità per eventuali danni causati dalla mancata osservanza della presente "Comunicazione tecnica".

Disposizioni relative alla protezione ambientale



Per tutti i lavori su e con il movimento dell'orologio si dovranno rispettare le disposizioni di legge relative al corretto riciclaggio e smaltimento dei rifiuti!

In particolare si dovrà provvedere al corretto smaltimento di lubrificanti e detersivi nocivi per l'ambiente!



Le sostanze inquinanti per l'acqua devono essere conservate, trasportate, raccolte e smaltite in contenitori adatti.

Queste non devono inquinare il terreno o arrivare nelle canalizzazioni!

Spiegazione dei simboli



Attenzione! Pericolo di danni materiali!

Seguono importanti indicazioni che devono essere tassativamente rispettate per evitare danni materiali!

List of components - Lista de piezas - Lista fornitori

Pos	No	No CS	Article number Número de artículo Numero articolo		List of components	Lista de piezas	Lista fornitori
1	100	10.020.06	Var		Main plate, assembled	Platina, montada	Piastra, montata
1-1	144	10.300.00	7613226002043		Dial fastener	Sujetador de cuadrante	Ferma-quadrante
1-2	3025	70.531.00	7613226021617		Jewelled shock-absorber, for balance, shouldered, to press in, bottom INCABLOC	Amortiguador empedrado, de volante, de embutir, de asiento, debajo INCABLOC	Ammortizzatore con pietra, del bilanciante, a pressione, con piano di appoggio, sotto INCABLOC
2	407	31.121.00	7613226034341		Sliding pinion	Piñón corredizo	Pignone scorrevole
3	410	31.120.00	7613226038899		Winding pinion	Piñón de remontuar	Pignone di carica
4	401	51.010.00	7613226050372		Winding stem	Tija de remontuar	Albero di carica
5	443	51.080.00	7613226019362		Setting lever	Tirete	Tiretto
6	435	51.050.00	7613226054912		Yoke	Báscula de piñón corredizo	Bascula del pignone scorrevole
7	440	61.100.00	7613226052796		Yoke spring	Muelle de báscula	Molla della bascula
8	450	31.100.00	7613226007932		Setting wheel	Rueda de transmisión	Rinvio
9	260	31.041.00	7613226021020		Minute wheel	Rueda de minutería	Ruota della minuteria
10	445	51.090.00	7613226000100		Setting lever jumper	Muelle flexible de tirete	Scatto del tiretto
11	705	30.040.00	7613226045576		Escape wheel	Rueda de escape	Ruota di scappamento
12	220	30.027.00	Var		Second wheel, assembled	Rueda de segundos, montada	Ruota dei secondi, montata
13	210	30.025.00	7613226031784		Third wheel	Rueda primera	Ruota mediana
14	201	30.015.00	7613226048225		Centre wheel	Rueda de centro	Ruota di centro
15	110	10.048.07	Var		Train wheel bridge, jewelled	Puente de rodaje, empedrado	Ponte del ruotismo con pietre
16	180/1	20.010.00	7613226033573		Movement barrel, complete	Cubo completo de máquina	Bariletto completo del movimento
17	105	10.041.07	Var		Barrel bridge, jewelled	Puente de cubo, empedrado	Ponte del bariletto, con pietre
18	420	31.023.00	Var		Crown wheel	Rueda de corona	Ruota a corona
19	423	81.136.00	Var		Crown wheel core	Sombbrero de rueda de corona	Nocciolo della ruota a corona
20	425	51.120.00	7613226039230		Click	Trinquete	Cricco
21	430	61.080.00	7613226003040		Click spring	Muelle de trinquete	Molla del cricco
22	415	31.020.00	Var		Ratchet wheel	Rochete	Rocchetto
23	710	40.010.06	7613226056251		Pallet fork, assembled	Áncora, montada	Ancora, montata
24	125	10.057.07	Var		Pallet bridge, jewelled	Puente de áncora, empedrado	Ponte dell'ancora, con pietre
25	721	40.050.21	7613226056398		Timed balance regulated, with stud, chronometer	Volante regulado, con pitone, cronometro	Bilanciere regolato, con pitón, cronometro
26	121	10.058.06	Var		Balance bridge, assembled	Puente de volante, montado	Ponte del bilanciere, montato
26-1	121/3	10.058.61	Var		Balance bridge	Puente de volante	Ponte del bilanciere
26-2	307/1	40.301.06	7613226036895		Regulator without pointer, assembled	Raqueta sin flecha, montada	Racchetta senza freccia, montata
26-3	375	40.200.00	7613226026438		Stud support	Porta-pitón	Portapitone
26-4	3024	70.500.00	7613226037687		Jewelled shock-absorber, for balance, shouldered, to press in, top INCABLOC	Amortiguador empedrado, de volante, de embutir, de asiento, encima INCABLOC	Ammortizzatore con pietra, del bilanciante, a pressione, con piano di appoggio, sopra INCABLOC
27	240	31.080.00	Var		Driver cannon pinion	Cañón de minutos arrastrador	Pignone calzante conduttore
28	250	31.046.00	Var		Hour wheel	Rueda de horas	Ruota delle ore
900	-	88.502.00	Var	1x	Special screw - Pos. 5: Screw for setting lever	Tornillo especial - Pos. 5: Tornillo de tirete	Vite speciale - Pos. 5: Vite del tiretto
901	-	88.542.00	7613226051898	2x	Countersunk head screw - Pos. 10: Screw for setting lever jumper	Tornillo cabeza cónica - Pos. 10: Tornillo del muelle flexible de tirete	Vite testa cónica - Pos. 10: Vite del scatto del tiretto
902	-	88.502.01	Var	2x	Cylindrical head screw - Pos. 15: Screw for train wheel bridge	Tornillo cabeza cilindrico - Pos. 15: Tornillo de puente de rodaje	Vite testa cilindrico - Pos. 15: Vite del ponte del ruotismo
				3x	- Pos. 17: Screw for barrel bridge	- Pos. 17: Tornillo del puente de cubo	- Pos. 17: Vite del ponte del bariletto
				1x	- Pos. 26: Screw for balance bridge	- Pos. 26: Tornillo del puente de volante	- Pos. 26: Vite del ponte del bilanciere
903	-	88.542.01	Var	2x	Countersunk head screw - Pos. 19: Screw for crown wheel core	Tornillo cabeza cónica - Pos. 19: Tornillo del sombrero de rueda de corona	Vite testa cónica - Pos. 19: Vite del nocciolo della ruota a corona
904	-	88.502.02	Var	1x	Cylindrical head screw - Pos. 20: Screw for click	Tornillo cabeza cilindrico - Pos. 20: Tornillo de trinquete	Vite testa cilindrico - Pos. 20: Vite del cricco
905	-	88.502.03	Var	1x	Cylindrical head screw - Pos. 22: Screw for ratchet wheel	Tornillo cabeza cilindrico - Pos. 22: Tornillo del rochete	Vite testa cilindrico - Pos. 22: Vite per il rocchetto
906	-	88.502.04	Var	1x	Cylindrical head screw - Pos. 24: Screw for pallet bridge	Tornillo cabeza cilindrico - Pos. 24: Tornillo del puente de áncora	Vite testa cilindrico - Pos. 24: Vite del ponte d'ancora

Pos	No	No CS	Article number Número de artículo Numero articolo	List of components	Lista de piezas	Lista fornitori
			Var	Variante	Variante	Variant

**Interchangeability and variants
can be found on the
ETA ONLINE SHOP (EOS):**

www.eta.ch

- Support Center
- Support Center Portal

**La intercambiabilidad y las
variantes se encuentran en
ETA ONLINE SHOP (EOS):**

www.eta.ch

- Support Center
- Support Center Portal

**L'intercambiabilità e le varianti si
trovano sul
ETA ONLINE SHOP (EOS):**

www.eta.ch

- Support Center
- Support Center Portal

Materials - Fornituras - Forniture

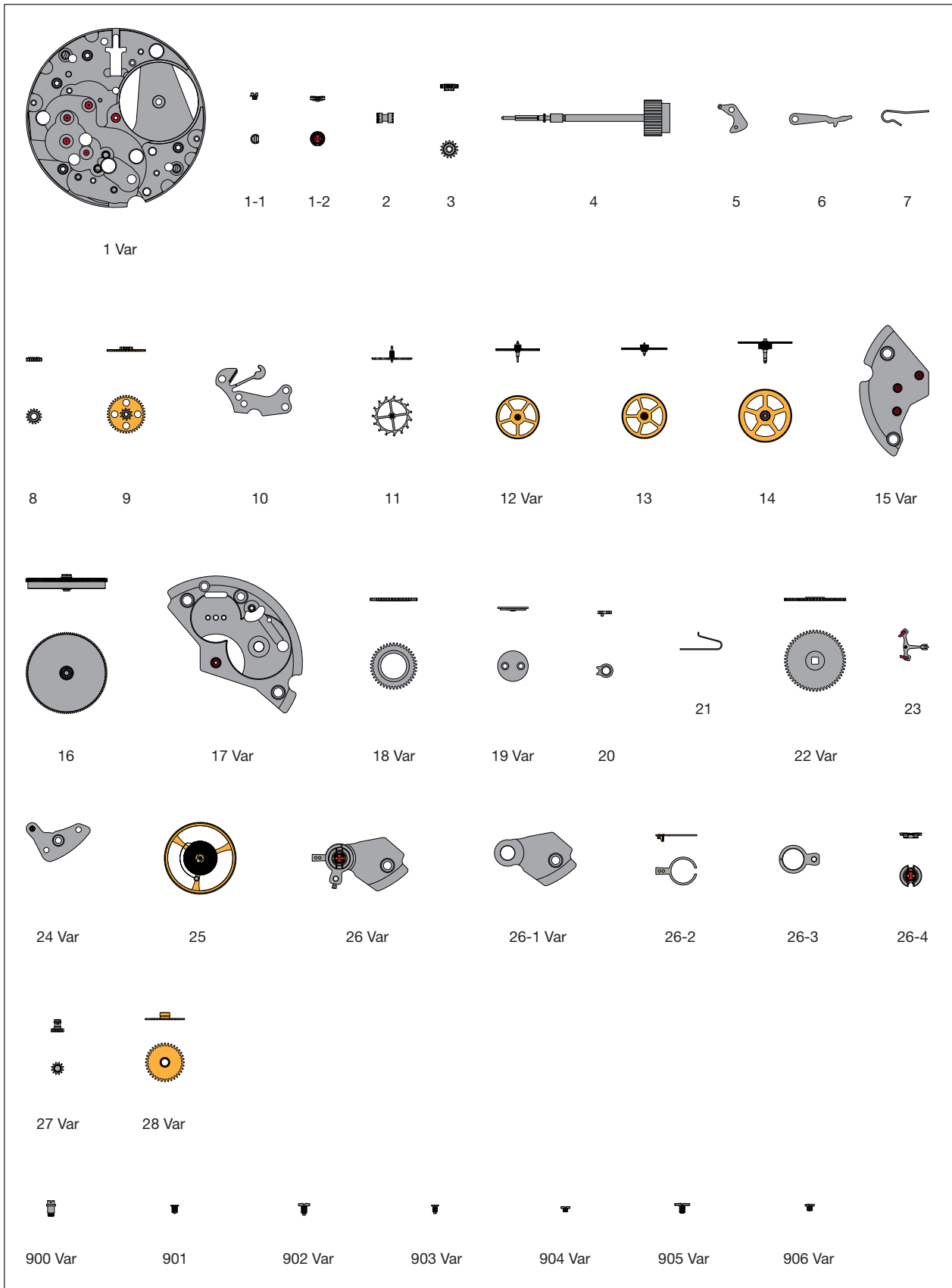

Order of assembly - Orden del montaje - Odine dell'assemblaggio:
 Handsetting mechanism - Mecanismo de puesta en hora - Meccanismo dell messa all'ora

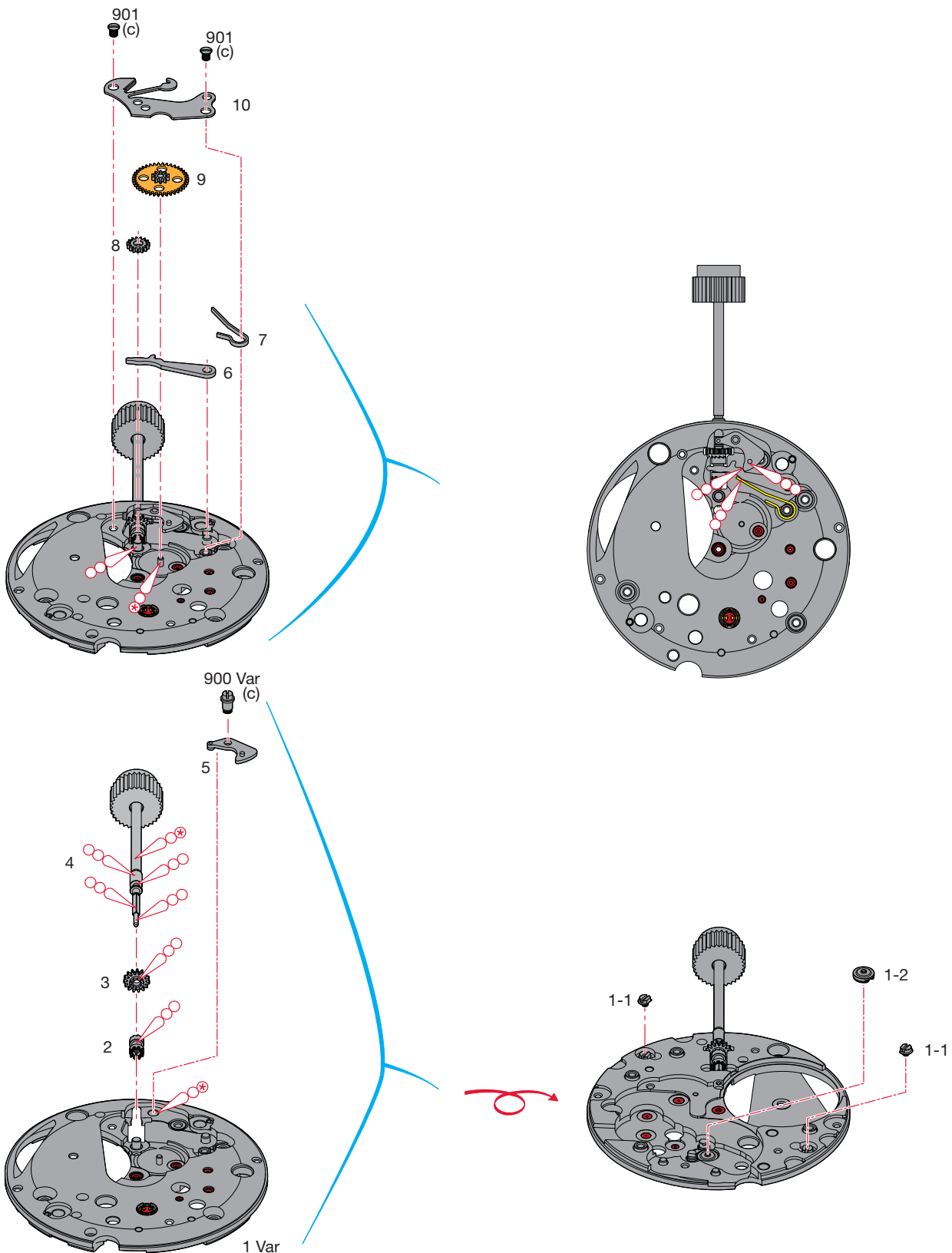

Assembling of the handsetting mechanism

(Parts listed in order of assembly)

Montaje del mecanismo de puesta en hora

(Lista de fornitureas por orden de ensamblado)

Montaggio del meccanismo della messa all'ora

(Elenco delle forniture in ordine di montaggio)

1 Var	5	9
2	6	10
3	7	901 (2x)
4	8	

Lubrication - Lubricación - Lubrificazione

Thick oil or grease
 Aceite espeso o grasa
 Olio denso o grasso

**Moebius
 HP-1300
 or / ó / o
 Moebius D5**



Very small quantity
 Cantidad muy pequeña
 Piccolissima quantità

**Moebius
 HP-1300
 or / ó / o
 Moebius D5**

M_L Minimum torque for loosening**M_L Par mínimo para desatornillar****M_L Coppia minima per svitare**

(c) 0,7 Ncm

Order of assembly - Orden del montaje - Odine dell'assemblaggio:
 Basic movement - Máquina de base - Movimento di base

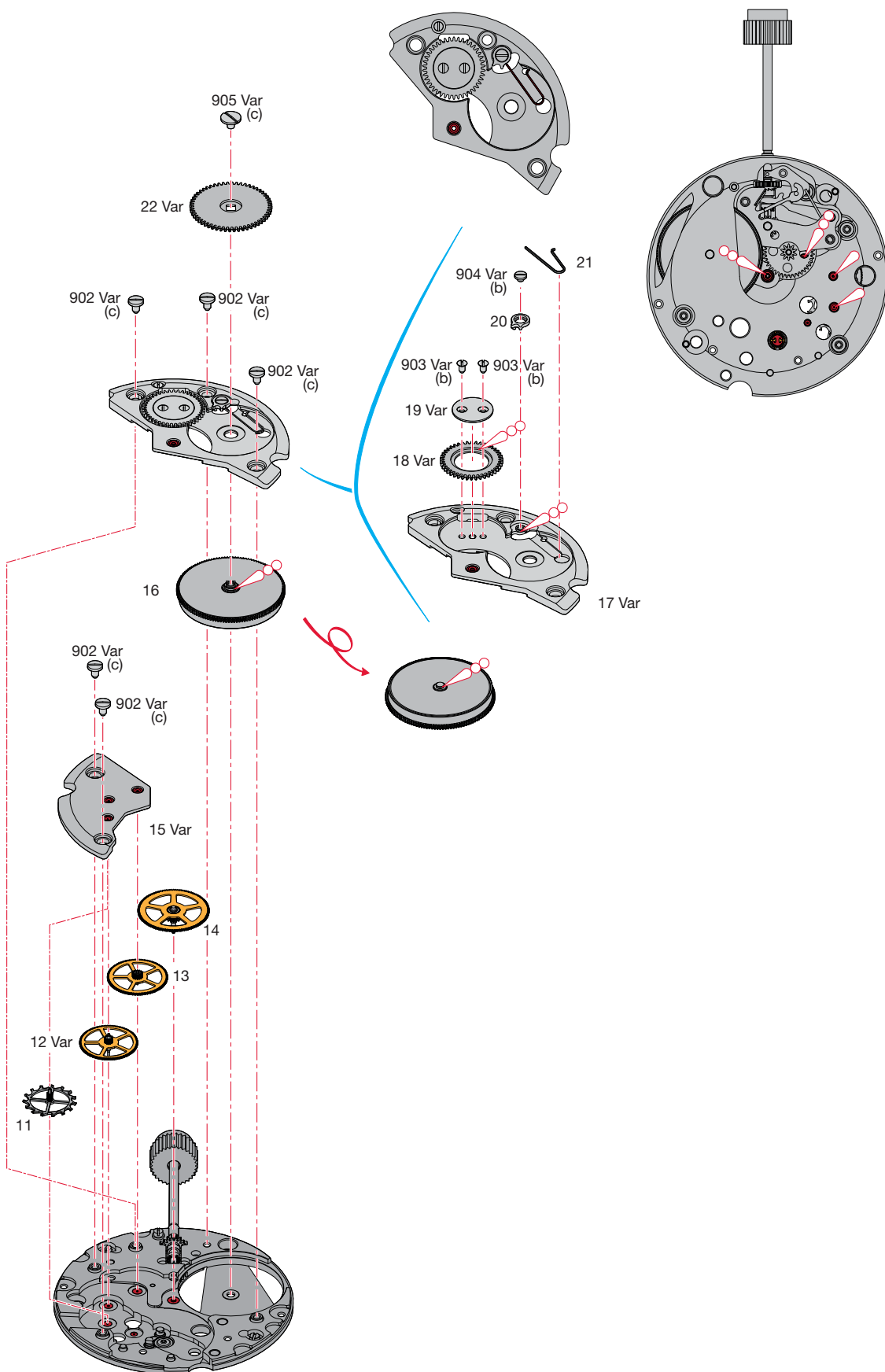

Assembling of the basic movement

(Parts listed in order of assembly)

Montaje de la máquina de base



(Lista de fornitureas por orden de ensamblado)

Montaggio del movimento di base

(Elenco delle forniture in ordine di montaggio)

11	16	904 Var (1x)
12 Var	17 Var	21
13	18 Var	902 Var (3x)
14	19 Var	22 Var
15 Var	903 Var (2x)	905 Var (1x)
902 Var (2x)	20	

Lubrication - Lubricación - Lubrificazione

	Thick oil or grease Aceite espeso o grasa Olio denso o grasso	Moebius HP-1300 or / ó / o Moebius D5
	Fine oil Aceite fino Olio fluido	Moebius 9010

M_L Minimum torque for loosening**M_L Par mínimo para desatornillar****M_L Coppia minima per svitare**

- (b) 0,6 Ncm
- (c) 0,7 Ncm

Order of assembly - Orden del montaje - Odine dell'assemblaggio:
 Basic movement - Máquina de base - Movimento di base

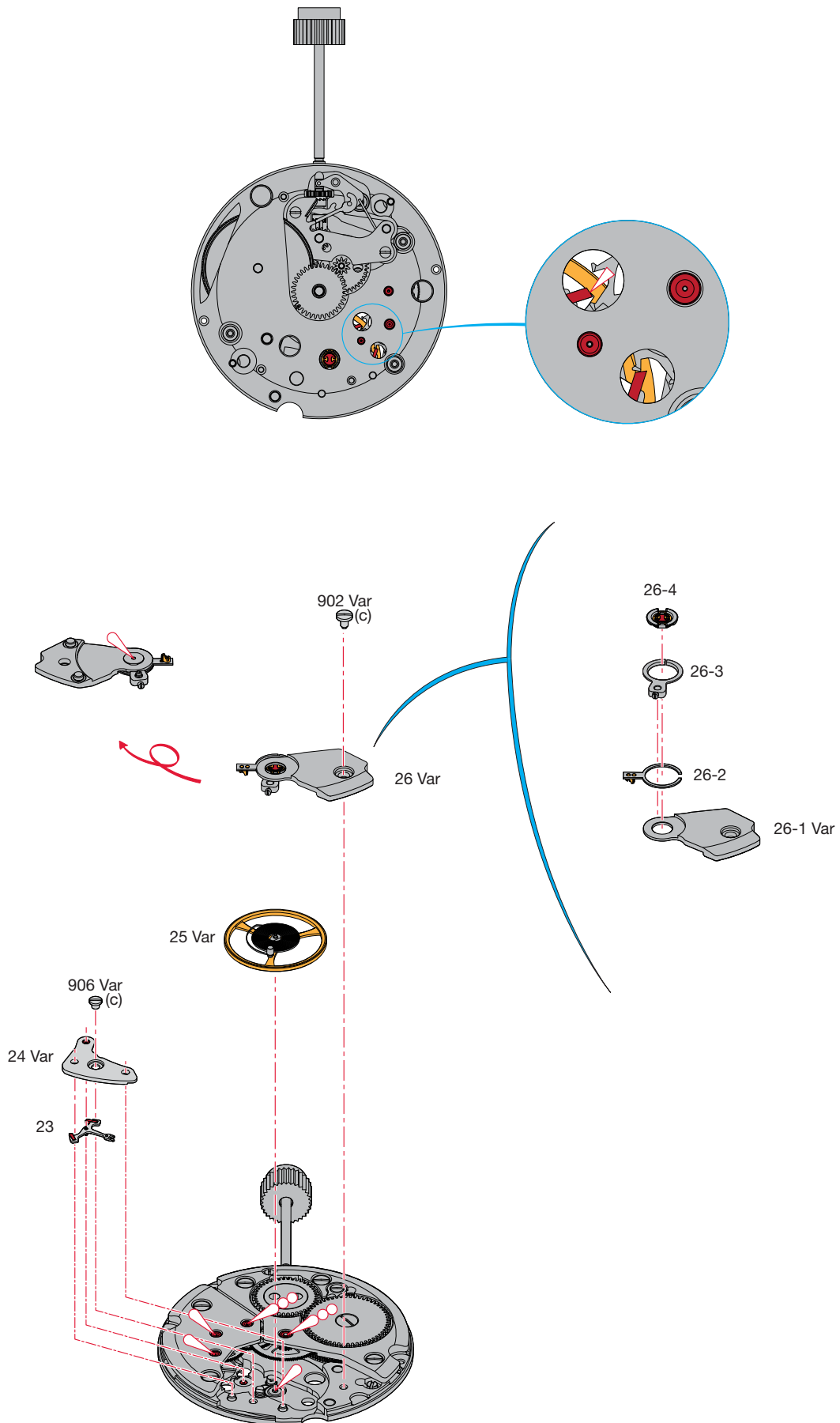

Assembling of the basic movement

(Parts listed in order of assembly)

Montaje de la máquina de base

(Lista de fornitureas por orden de ensamblado)

Montaggio del movimento di base

(Elenco delle forniture in ordine di montaggio)

23	25 Var
24 Var	26 Var
906 Var (1x)	902 Var (1x)

Lubrication - Lubricación - Lubrificazione

	Thick oil or grease Aceite espeso o grasa Olio denso o grasso	Moebius HP-1300 or / ó / o Moebius D5
	Fine oil Aceite fino Olio fluido	Moebius 9010
	Special oil for pallet stones Aceite especial para escape Olio speciale per scappamento	Moebius 941 or / ó / o Moebius 9415

M_L Minimum torque for loosening**M_L Par mínimo para desatornillar****M_L Coppia minima per svitare**

- (a) 0,25 Ncm
- (c) 0,7 Ncm

Order of assembly - Orden del montaje - Odine dell'assemblaggio:
Wheel train - Rodaje - Ruotismo

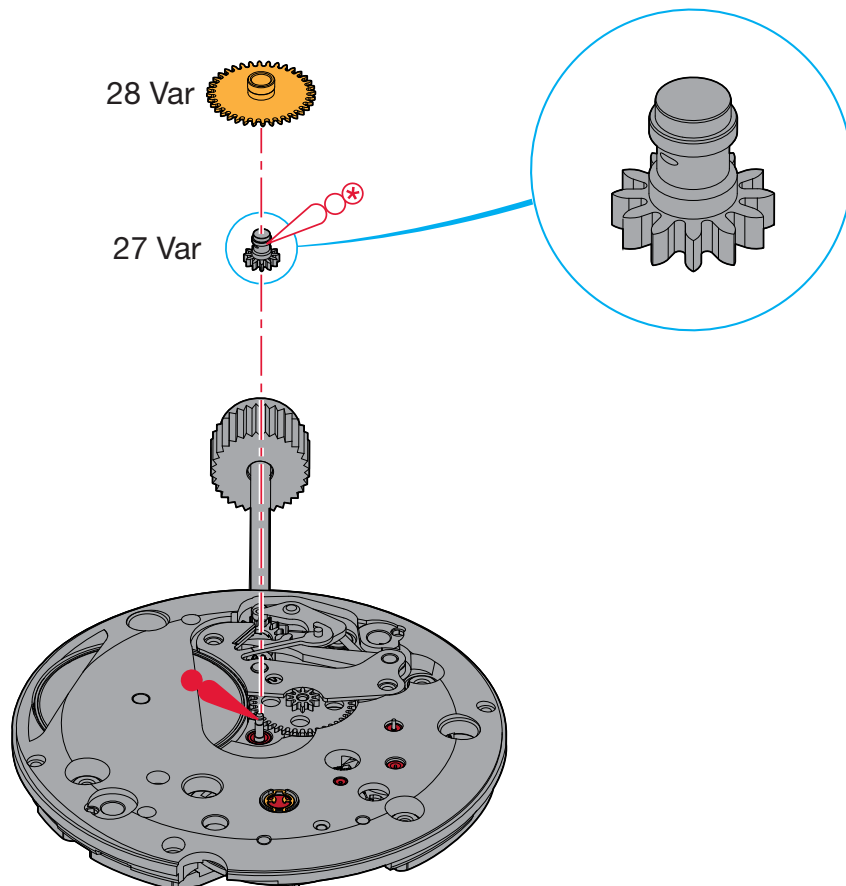

Assembling of the wheel train

(Parts listed in order of assembly)

Montaje del rodaje

(Lista de fornituras por orden de ensamblado)

Montaggio del ruotismo

(Elenco delle forniture in ordine di montaggio)

27 Var

28 Var

Lubrication - Lubricación - Lubrificazione

Very small quantity

Cantidad muy pequeña

Piccolissima quantità

Moebius

HP-1300

or / ó / o

Moebius D5



Grease

Grasa

Grasso

Moebius 9501

or / ó / o

Jismaa 124

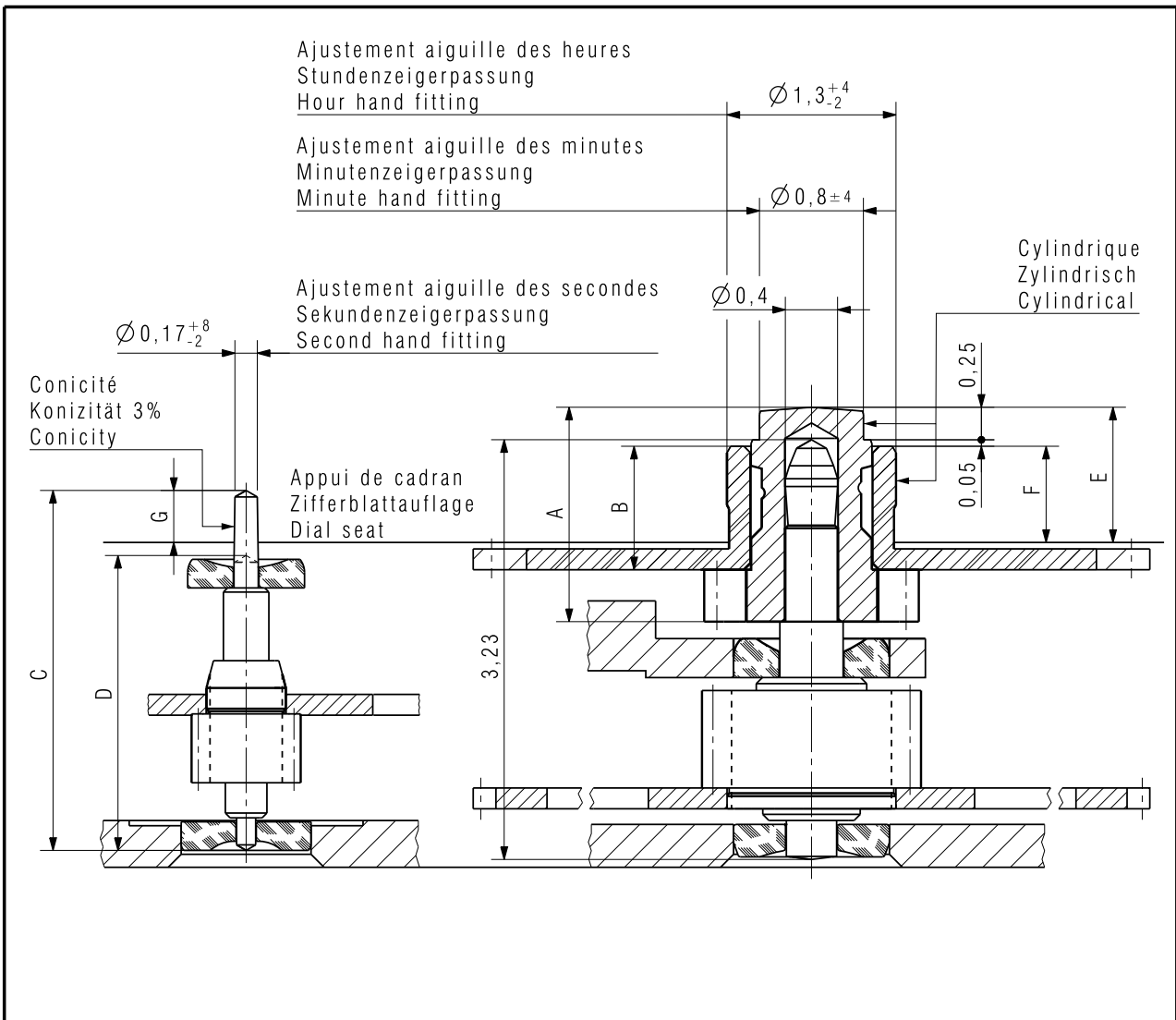

Aiguillage Zeigerwerkhöhe Hand fitting height	Longueur / Länge / Length				Höhe über Zifferblattaufgabe Height over dial seat Dépassement		
	A	B	C	D	E	F	G
1	1,65	0,95	2,77	sans sec. ohne Sek. without sec. 2,27	1,04	0,74	0,40
2 normal	1,80	1,10	2,77		1,19	0,89	0,40
3	1,95	1,25	2,77		1,34	1,04	0,40
4	2,20	1,50	2,77		1,59	1,29	0,40

Kaliber / Calibre / Caliber 7001	Masstab Echelle Scale --		CATIA V5
		Masse in mm Dimensions en mm Dimensions in mm	Tol. 1/1000 mm

AIGUILLAGES ZEIGERWERKHÖHEN HAND FITTING HEIGHTS	Version 04	Revision 00	Blatt Feuille Sheet 01/01
Z0091272	04	00	01/01

ETA SA MANUFACTURE HORLOGÈRE SUISSE DEPUIS 1793 A COMPANY OF THE SWATCH GROUP	Ersatz für/En remplacement de/Remplacement for	Klass. Class. ZVACC	KUN	
	Aenderung/Modification	Erstellt Etabli Created 07.04.2009	Gepfüt Contrôlé Controlled FRL	Freigegeben Libéré Released 13.11.2009
	24551	07.04.2009	FRL	13.11.2009

We reserve all rights for this document. It is meant for the recipient only and it may not be copied, printed or given to a third person without our written permission. Quedan reservados todos los derechos relacionados con este documento, que está dirigido únicamente al destinatario. Queda por lo tanto prohibida su copia, impresión a terceros sin nuestra autorización por escrito. Ogni diritto su questo documento è riservato. Il documento è indirizzato esclusivamente al destinatario e non può essere copiato, stampato o ceduto a terzi senza un'autorizzazione scritta.

This page has deliberately been left blank in case of A3 format printing.

Esta página se han dejado en blanco a propósito en caso de imprimirla en formato A3.

Questa pagina è lasciata intenzionalmente bianca in caso di stampa formato A3.

Modifications compared with previous document versions**Modificaciones comparadas con las versiones anteriores del documento****Modifiche comparate con le versioni precedenti del documento**

Version Versión Versione	Date Fecha Data	Modification	Modificación	Modifica	Page Página Pagina
06	11.09.2014	Adaptation variant and GTIN number	Adaptación variante y número GTIN	Adattamento variante e numero GTIN	3-13
05	14.11.2011	Order of spare parts correction	Corrección del orden de piezas	Correzioni ordine delle forniture	5
		Addition variant in list of components	Adición variante lista de piezas	Aggiunta variante lista fornitori	3-4
		Montage modifications	Modificaciones montaje	Modifiche d'assemblaggio	6-13
04	18.11.2009	Remove parts No. 224, 5101 and 5102	Eliminar piezas No. 224, 5101 y 5102	Soppressione degli pezzi No 224, 5101 e 5102	2
		New drawing	Nuevo plan	Nuovo disegno	7
		New layout	Nuevo layout	Nuova layout	1-8
03	02.12.2003	Basis version	Versión de base	Versione di base	--

All modifications reserved.

Salvo modificación.

Con riserva di ogni eventuale modifica.

This document can be found on the
Support Center Portal (SCP):

www.eta.ch

- Support Center
- Support Center Portal
- Technical Documents

Este documento se encuentran en el
Support Center Portal (SCP):

www.eta.ch

- Support Center
- Support Center Portal
- Technical Documents

Il presente documento si trovano sul
Support Center Portal (SCP):

www.eta.ch

- Support Center
- Support Center Portal
- Technical Documents



ETA^{SA}
MANUFACTURE HORLOGÈRE SUISSE
DEPUIS 1793

SC PRODUCT COMMUNICATION

Bahnhofstrasse 9
2540 Grenchen
Switzerland

Phone +41 (0)32 655 71 11
Fax +41 (0)32 655 71 74

contact@eta.ch
www.eta.ch