

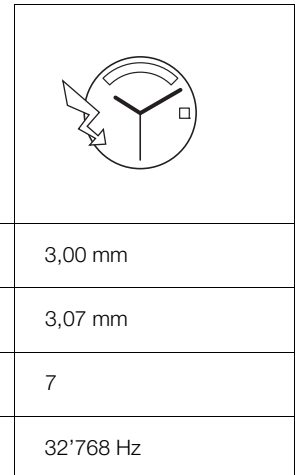

11 1/2" ETA 955.132

CT 955132 FDE 491861 09 06.02.2015

11 1/2" Ø 25,60 mm



Hauteur sur mouvement	Höhe auf Werk	Movement height	3,00 mm
Hauteur sur pile	Höhe auf Batterie	Height on battery	3,07 mm
Nombre de rubis	Anzahl Rubine	Number of jewels	7
Fréquence	Frequenz	Frequency	32'768 Hz

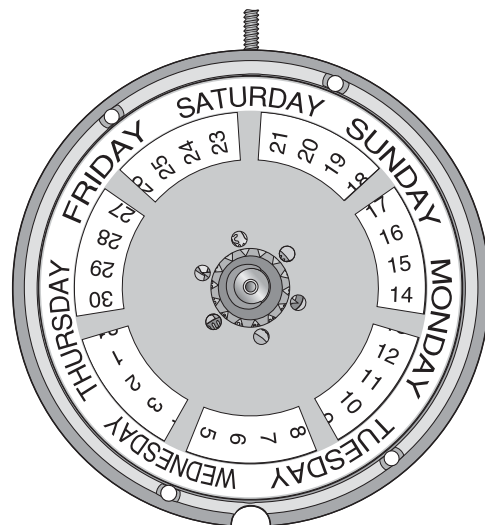
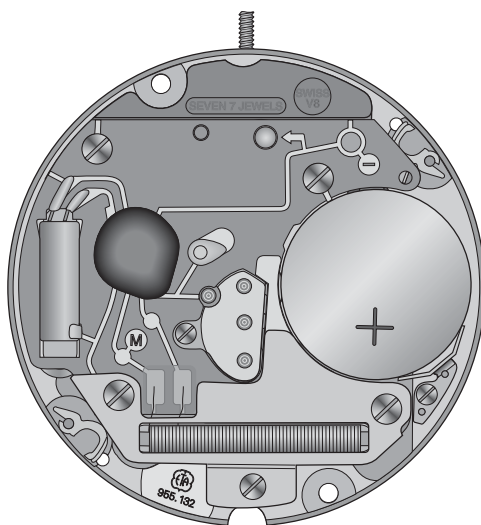

Les travaux de réparation et de révision ne doivent être effectués que par du personnel dûment formé.
Reparatur- und Revisionsarbeiten dürfen nur von ausgebildetem Fachpersonal ausgeführt werden.
The repair and reconditioning work must only be performed by properly trained personnel.



Informations générales



Avant de démarrer les travaux, veuillez svp étudier attentivement cette "*Communication technique*".



La protection des yeux est obligatoire pour toutes les interventions / tous les travaux sur le mouvement!



ETA SA décline toute responsabilité en cas de dommages du non respect de cette "*Communication technique*".

Exigences en matière de protection de l'environnement



Les dispositions légales en matière de traitement et d'élimination des déchets doivent être respectées lors de toutes les interventions / tous les travaux sur les mouvements!

En particulier, les produits de graissage et de nettoyage néfastes pour l'environnement doivent être éliminés selon les règles!



Les **substances de nature à polluer l'eau** doivent être entreposées, transportées, récupérées et éliminées dans des récipients adéquats.

Elles ne doivent en aucun cas polluer le sol ou être évacuées dans les réseaux de canalisation!

Explication des symboles



Attention! Risque de dégât matériel!

Ci-après quelques instructions à suivre obligatoirement pour éviter tout dégât matériel!



Ci-après quelques conseils d'utilisations et informations importantes.

Allgemeine Informationen



Diese "*Technische Mitteilung*" ist **vor** dem Beginn der Arbeiten genauestens zu studieren.



Für sämtliche Arbeiten am und mit dem Uhrwerk ist ein Augenschutz obligatorisch!



Für Schäden, welche durch Nichtbeachtung dieser "*Technischen Mitteilung*" entstehen, haftet die ETA SA nicht.

Umweltschutz-Vorschriften



Bei allen Arbeiten am und mit dem Uhrwerk sind die gesetzlichen Vorschriften zur ordnungsgemässen Verwertung und Beseitigung der Abfälle einzuhalten!

Insbesondere sind umweltgefährdende Schmier- und Reinigungsmittel ordnungsgemäss zu entsorgen!



Wassergefährdende Stoffe müssen in geeigneten Behältern aufbewahrt, transportiert, aufgefangen und entsorgt werden.

Diese dürfen nicht den Boden belasten oder in die Kanalisation gelangen!

Symbolerklärung



Achtung! Gefahr von Sachschäden!

Hier folgen wichtige Hinweise, die zur Vermeidung von Sachschäden unbedingt beachtet werden müssen!



Hier folgen Anwendungstipps und wichtige Informationen.

General information



Before starting work, please study this "*Technical communication*" carefully.



Eye protection is obligatory for all operations / work on the movement!



ETA SA disclaims any liability in case of damage arising from failure to observe this "*Technical communication*".

Environmental protection requirements



The legal provisions relating to waste handling and disposal must be observed in all operations / work on the movement!

In particular, lubricating and cleaning products harmful to the environment must be disposed of in accordance with the rules!



Substances prone to cause water pollution must be stored, transported, collected and disposed of in appropriate vessels.

Under no circumstances must they pollute the soil or be poured into sewage systems!

Explanation of symbols



Caution! Risk of material damage!

Below are some obligatory instructions for preventing any material damage!



Below is some advice for use and important information.

Liste des fournitures - Bestandteilliste - List of components

Pos	No Nr No	No Nr CS No	Numéro d'article Artikelnummer Article number	Liste des fournitures	Bestandteilliste	List of components
-	100	10.020.07	-	Platine, empierrée	Werkplatte, mit Steinen	Main plate, jewelled
-	110	10.048.07	Var	Pont de rouage, empierré	Räderwerkbrücke, mit Steinen	Train wheel bridge, jewelled
-	144	10.300.00	-	Fixateur de cadran	Zifferblatthalter	Dial fastener
-	145	10.106.00	-	Support de cadran	Träger für Zifferblatt	Dial support
-	147	10.280.00	-	Porte-marque	Platte für Markenzeichen	Mark support
-	161	80.400.00	-	Tube de centre	Zentrallagerrohr	Centre tube
-	203	30.012.00	-	Roue intermédiaire	Zwischenrad	Intermediate wheel
-	210	30.025.00	-	Roue moyenne	Kleinbodenrad	Third wheel
-	227	30.027.00	Var	Roue de seconde	Sekundenrad	Second wheel
-	242	31.083.00	Var	Chaussée avec roue entraîneuse	Minutenrohr mit Mitnehmerrad	Cannon pinion with driving wheel
-	255	31.046.00	Var	Roue des heures	Stundenrad	Hour wheel
-	260	31.041.00	-	Roue de minuterie	Wechselrad	Minute wheel
-	405	51.020.21	Var	Tige de mise à l'heure	Stellwelle	Handsetting stem
-	407	31.121.00	-	Pignon coulant	Kupplungstrieb	Sliding pinion
-	435	51.050.00	-	Bascule de pignon coulant	Kupplungstriebhebel	Yoke
-	443/1	51.080.06	-	Tirette montée	Winkelhebel, montiert	Setting lever, assembled
-	445	51.090.00	-	Sautoir de tirette	Winkelhebelraste	Setting lever jumper
-	450	31.100.00	-	Renvoi	Zeigerstellrad	Setting wheel
-	462	10.062.00	-	Pont de rouage de minuterie	Wechselradbrücke	Minute train bridge
-	549	81.185.00	-	Clavette de tirette	Klemmscheibe für Winkelhebel	Setting lever spring-clip
-	560	56.071.00	-	Levier d'arrêt et interrupteur	Stoppehebel und Unterbrecher	Stop lever and switch
-	2543	33.011.00	-	Roue intermédiaire de quantième	Datum-Zwischenrad	Intermediate date wheel
-	2555	33.028.00	-	Roue entraîneuse du calendrier	Kalender-Mitnehmerrad	Calendar driving wheel
-	2557/1	91.440.22	Var	Indicateur de quantième, ouverture de guichet à 3 h	Datumanzeiger, für Fenster bei 3 Uhr	Date indicator, for window opening at 3 o'clock
-	2561/1	91.441.21	Var	Indicateur du jour pour ouverture en arc de cercle à 12 h	Tagesanzeiger, für Bogenförmiges Fenster bei 12 Uhr	Day indicator, for circular arc opening at 12 o'clock
-	2567	53.201.00	-	Correcteur des jours	Tageskorrektor	Day corrector
-	2569	53.204.00	-	Correcteur double	Doppelkorrektor	Double corrector
-	2570	53.026.00	-	Commande du correcteur double	Schalthebel für Doppelkorrektor	Double corrector operating lever
-	2573	63.032.00	-	Ressort du sautoir des jours	Feder für Tagesraste	Day jumper spring
-	2576	53.080.00	-	Sautoir de quantième	Datumraste	Date jumper
-	2577	53.081.00	-	Sautoir des jours	Tagesraste	Day jumper
-	2595	13.111.00	-	Plaque de maintien du sautoir de quantième	Halteplatte für Datumraste	Date jumper maintaining plate
-	2780	83.171.00	-	Clavette de l'indicateur du jour	Klemmscheibe für Tagesanzeiger	Day indicator spring clip
-	4000	10.513.00	Var	Module électronique	Elektronik-Baugruppe	Electronic module
-	4021	20.582.00	-	1x Stator	Stator	Stator
-	4022	80.102.00	Var	Entretoise du module électronique	Zwischenstück für Elektronik-Baugruppe	Electronic module distance piece
-	4038	20.584.00	-	Ecran magnétique supérieur	Oberer Magnetschirm	Upper magnetic screen
-	4046	20.651.00	-	Isolateur de pile	Isolation für Batterie	Battery insulator
-	4211	20.580.00	-	Rotor	Rotor	Rotor
-	4233	80.246.00	-	Rivet de stator	Niet für Stator	Rivet for stator
-	4407	20.764.00	-	Bride +	Bügel +	Bridle +
-	4412	10.601.00	-	Ressort de limitation de pile	Begrenzungsfeder für Batterie	Battery limiting spring
-	4929	20.570.00	Var	Pile	Batterie	Battery
-	5110	10.048.01	Var	1x Vis de pont de rouage	Schraube für Räderwerkbrücke	Screw for train wheel bridge
1)	5462	10.062.01	-	1x Vis de pont de rouage de minuterie	Schraube für Wechselradbrücke	Screw for minute train bridge
-	52567	53.201.01	-	1x Vis de correcteur des jours	Schraube für Tageskorrektor	Screw for day corrector
1)	52573	63.032.01	-	1x Vis de ressort du sautoir des jours	Schraube für Tagesrastefeder	Screw for day jumper spring
1)	52595	13.111.01	-	1x Vis de plaque de maintien du sautoir de quantième	Schraube für Halteplatte für Datumraste	Screw for date jumper maintaining plate
-	54000	10.513.01	Var	4x Vis de module électronique, longue	Schraube für Elektronik-Bau-Gruppe, lang	Screw for electronic module, long
-	54000 ¹	10.513.02	Var	1x Vis de module électronique, courte	Schraube für Elektronik-Baugruppe, kurz	Screw for electronic module, short
2)	54038	20.584.01	-	1x Vis d'écran magnétique	Schraube für oberen Magnetschirm	Screw for upper magnetic screen
2)	54407	20.764.01	-	1x Vis de bride +	Schraube für Bügel +	Screw for bridle +

Pos	No Nr No	No Nr CS No	Numéro d'article Artikelnummer Article number	Liste des fournitures	Bestandteilliste	List of components
				Vis identiques Identische Schrauben Identical screws	1) 5462 52573 52595	2) 54038 54407

**L'interchangeabilité et les variantes se trouvent sur
ETA ONLINE SHOP (EOS) :**

www.eta.ch
→ Support Center
→ Support Center Portal

**Die Austauschbarkeit und Varianten finden Sie im
ETA ONLINE SHOP (EOS):**

www.eta.ch
→ Support Center
→ Support Center Portal

**Interchangeability and variants
can be found on the
ETA ONLINE SHOP (EOS):**

www.eta.ch
→ Support Center
→ Support Center Portal

Fournitures - Bestandteile - Materials

100	110 Var	144	145	147	161	203	210	227 Var	5110 Var	
242 Var	255 Var	260	405 Var	407	435	443/1	445	450	462	549
560	2543	2555	2557/1 Var	2561/1 Var	2567	2569	2570	2573	2576	
2577	2595	2780	4000 Var	4021	4022 Var	4038	4046	4211	54000 Var	
4233	4407	4412	4929 Var						54000 ¹ Var 54038 54407	

Ordre d'assemblage - Montagereihenfolge - Order of assembly:
 Mouvement de base - Basiswerk - Basic movement

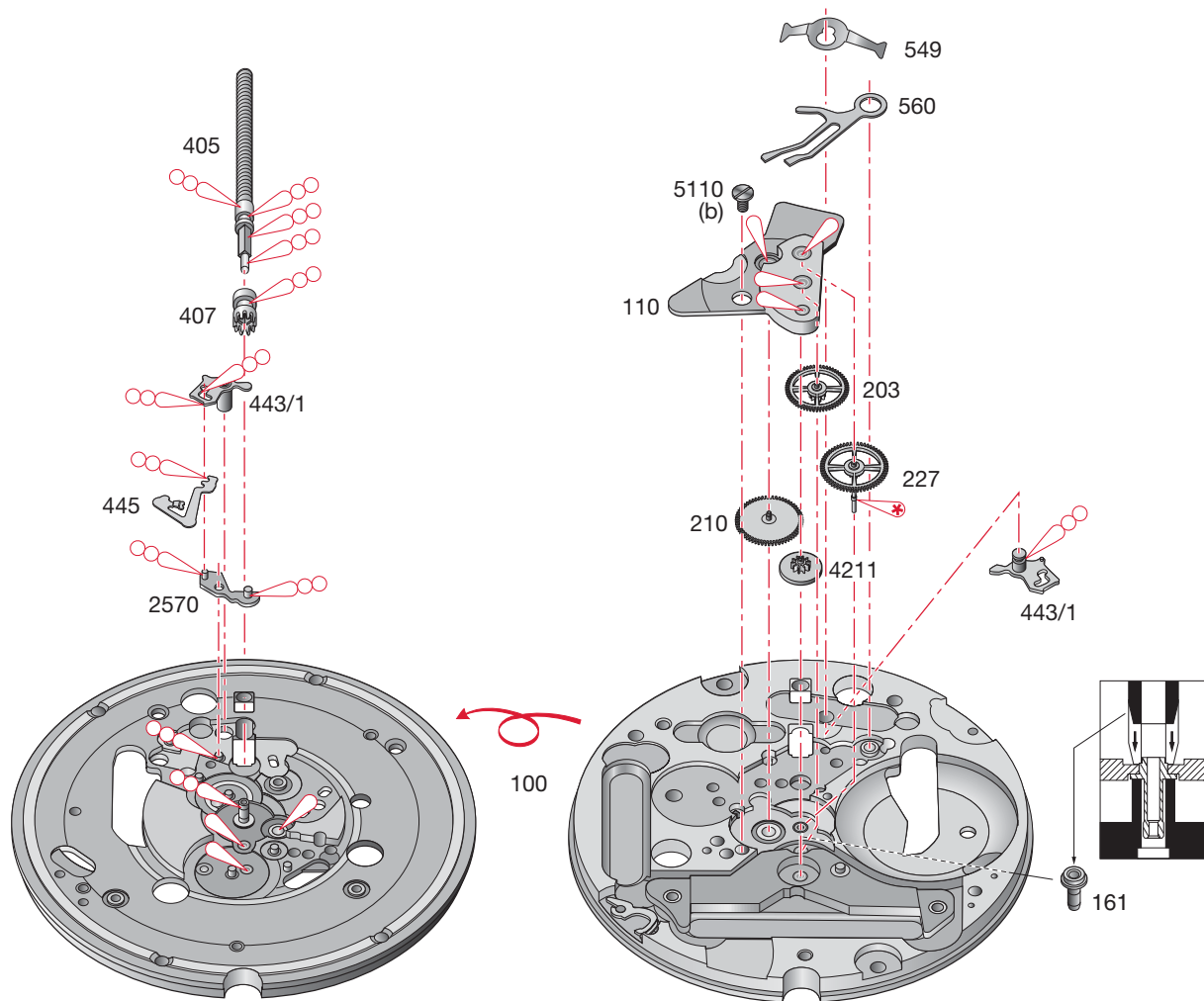

Montage du mouvement de base

(Liste des fournitures par ordre d'assemblage)

Zusammenstellen des Basiswerkes

(Bestandteilliste in Montager Reihenfolge)

Assembling of the basic movement

(Parts listed in order of assembly)

100	443/1	560
161	549	110
407	210	5110 (1x)
405	4211	
2570	227	
445	203	

Lubrification - Schmierung - Lubrication

 Huile fine **Moebius 9014**
 Düninflüssiges Öl ou / oder / or
 Fine oil **Moebius 9034**

 Huile épaisse ou graisse **Moebius**
 Dickflüssiges Öl oder Fett **HP-1300**
 Thick oil or grease ou / oder / or
Moebius D5

 Très faible quantité **Moebius 9014**
 Sehr kleine Menge ou / oder / or
 Very small quantity **Moebius 9034**

M_L Couple minimum pour dévisser**M_L Minimales Drehmoment zum Lösen****M_L Minimum torque for loosening**

(b) 0,7 Ncm

Ordre d'assemblage - Montager Reihenfolge - Order of assembly:
 Mécanismes de mise à l'heure et calendrier - Kalender- und Zeigerwerkmechanismus -
 Handsetting and calendar mechanisms

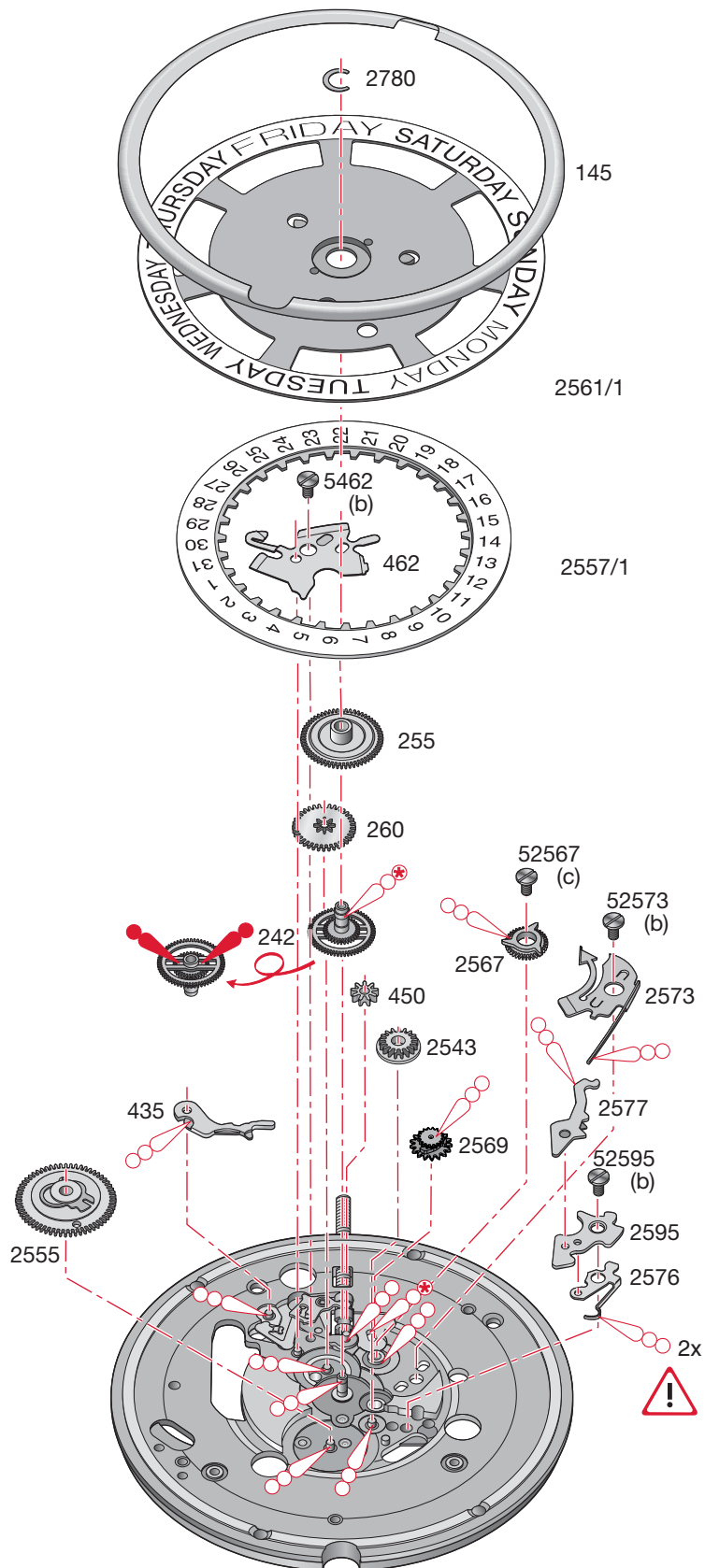

Montage du mécanisme de mise à l'heure et du mécanisme de calendrier

(Liste des fournitures par ordre d'assemblage)

Zusammenstellen des Zeigerwerkmechanismus und des Kalendermechanismus

(Bestandteilliste in Montager Reihenfolge)

Assembling of the handsetting mechanism and the calendar mechanism

(Parts listed in order of assembly)

242	5462 (1x)	2573
260	2557/1	52573 (1x)
450	2555	2577
2569	2543	2561/1
2567	2576	2780
52567 (1x)	2595	145
435	52595 (1x)	
462	255	

Lubrification - Schmierung - Lubrication



Huile épaisse ou graisse
Dickflüssiges Öl oder Fett
Thick oil or grease

**Moebius
HP-1300**
ou / oder / or
Moebius D5



Graisse
Fett
Grease

Moebius 9501
ou / oder / or
Jismaa 124



Très faible quantité
Sehr kleine Menge
Very small quantity

**Moebius
HP-1300**
ou / oder / or
Moebius D5

M_L Couple minimum pour dévisser

M_L Minimales Drehmoment zum Lösen

M_L Minimum torque for loosening

(b) 0,7 Ncm

	<p>Lubrifier la pièce 2576. 1. Teil 2576 schmieren. Lubricate part 2576.</p>
	<p>Tourner la pièce 2557/1 d'environ 10 dents avec la correction rapide. 2. Teil 2557/1 mit Schnellkorrektur ca. 10 Zähne drehen. Rotate part 2557/1 approx 10 teeth with rapide correction.</p>
	<p>Lubrifier à nouveau la pièce 2576. 3. Teil 2576 nochmals schmieren. Lubricate again part 2576.</p>
	<p>Tourner à nouveau la pièce 2557/1 d'environ 10 dents avec la correction rapide. 4. Teil 2557/1 nochmals mit Schnellkorrektur ca. 10 Zähne drehen. Rotate part 2557/1 approx 10 teeth with rapide correction again.</p>

Ordre d'assemblage - Montager Reihenfolge - Order of assembly:
 Mouvement de base et du module électronique - Basiswerkes und der Elektronik-Baugruppe - Basic movement and the electronic module

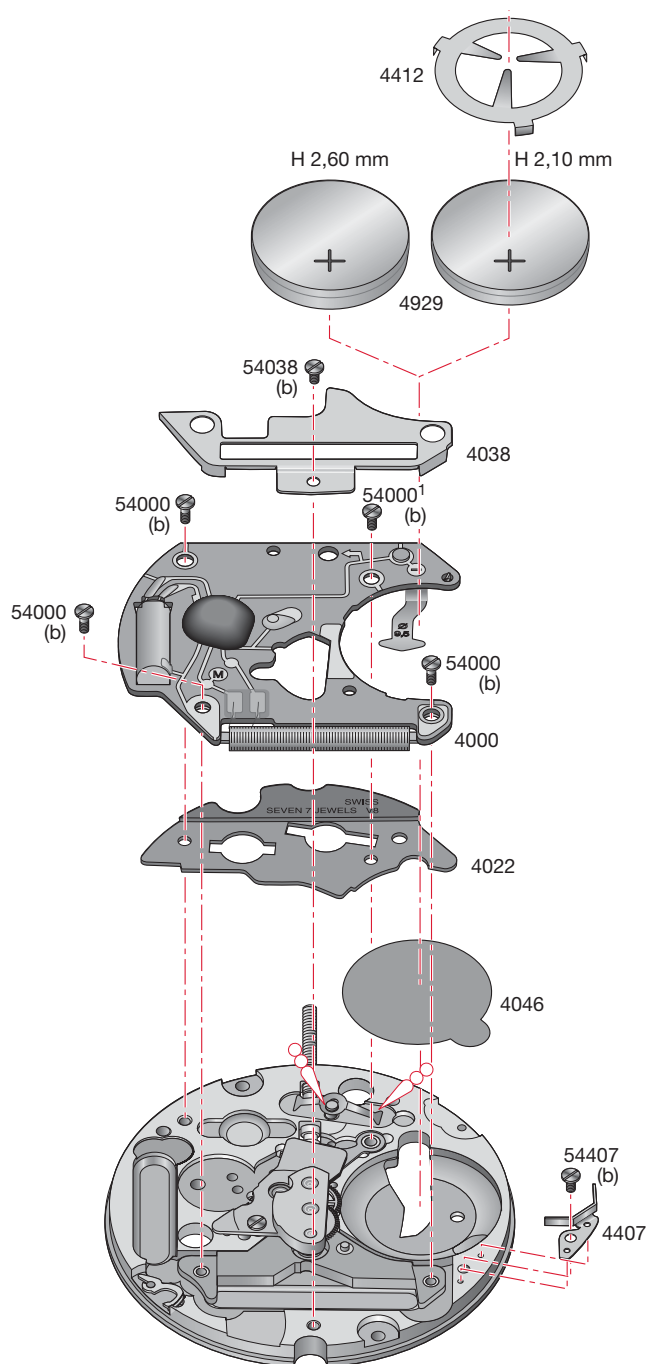

Montage du mouvement de base et du module électronique

(Liste des fournitures par ordre d'assemblage)

Zusammenstellen des Basiswerkes und der Elektronik-Baugruppe

(Bestandteilliste in Montagerihenfolge)

Assembling of the basic movement and the electronic module

(Parts listed in order of assembly)

4407	54000 ¹ (1x)	
54407 (1x)	4038	
4022	54038 (1x)	
4046	4929	
4000	4412	
54000 (3x)		

Lubrification - Schmierung - Lubrication



Huile épaisse ou graisse
Dickflüssiges Öl oder Fett
Thick oil or grease

Moebius
HP-1300
ou / oder / or
Moebius D5

M_L Couple minimum pour dévisser

M_L Minimales Drehmoment zum Lösen

M_L Minimum torque for loosening

(b) 0,7 Ncm

4412:

Nécessaire, si la sûreté entre le mouvement et le fond de la boîte est trop élevée.



Nur nötig, wenn der Abstand Werk Gehäuseboden zu gross ist.

To be fitted when the clearance between the movement and the case back is too great.

Contrôles électriques - Elektrische Kontrollen - Electrical Tests

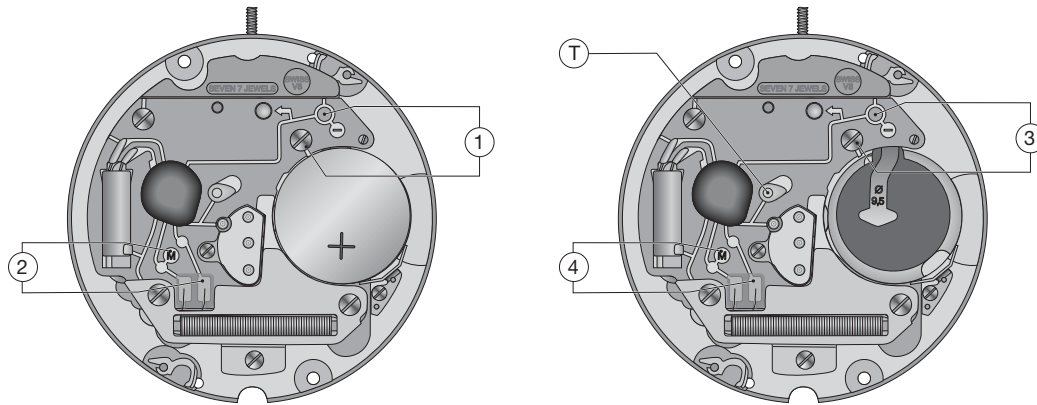

Position Messpunkt Position	Echelle de mesure Einstellung Messgerät Setting of apparatus	Mesure Messung Measurement	Contrôle Kontrolle Test	Remarques Bemerkungen Remarks
1	2 V ($R_i \geq 10 \text{ k}\Omega/V$)	1,55 V	Tension de la pile Spannung der Batterie Battery voltage	Mesure avec pile. Messung mit Batterie. Measurement with battery.
	2 V	Saut de 4 pas toutes les 4 sec. lorsque la tension d'alimentation < 1,30 V.	Fonction EOL. Test de l'indication de fin de vie de pile.	Mesure sans pile, avec tension d'alimentation < 1,30 V, fonction EOL après ~ 2 min.
		4 Schritte-Sprung alle 4 Sek., wenn Speisespannung < 1,30 V.	Funktion EOL. Test: Hinweis zur Batterie Anzeige.	Messung ohne Batterie, mit Speisespannung < 1,30 V, EOL-Funktion nach ca. 2 Min.
		4 steps jump every 4 sec., when feed voltage < 1.30 V.	EOL function. End of life test for the battery.	Measurement without battery, with feed voltage < 1.30 V, EOL-function after about 2 min.
2	1 V ($R_i \geq 10 \text{ k}\Omega / V$)	L'aiguille du multimètre oscille en sens + et -.	Impulsions à la sortie du circuit intégré: Fréquence 1/s.	Mesure avec une pile contrôlée.
		Zeiger im Messgerät pulsiert im + und - Sinn.	Ausgangsimpulse am integrierten Schaltkreis: Frequenz 1/s.	Messung mit Kontrollierter Batterie.
		Hand of measuring apparatus oscillates in + and - direction.	Impulses at output of integrated circuit: Frequency 1/s.	Measurement with controlled battery.
3	2 V 10 μA	$\leq 1,30 \text{ V}$ Mettre en contact le point T et la piste - . Commande du moteur avec 8 pas/s à 1,55 V et 32 pas/s avec tension $\leq 1,30 \text{ V}$ (EOL).	Limite inférieure de la tension de fonction- nement.	Mesure sans pile, alimentation exté- rieure variable, en descendant de 1,55 V à l'arrêt du mouvement.
		T Punkt mit der - Spur verbind- en. Motorantrieb mit 8 Schrt./Sek. bei 1,55 V und 32 Schrt./Sek. mit Spannung $\leq 1,30 \text{ V}$ (EOL).	Untere Funktionsspannungsgrenze.	Messung ohne Batterie mit variabler Speisung von aussen. Spannung von 1,55 V reduzieren bis zum Stillstand des Werkes.
	Connect T point with the - con- ductor. Motor driven with 8 steps/s at 1.55 V and 32 steps/s with voltage $\leq 1,30 \text{ V}$ (EOL).	Lower working-voltage limit.	Measurement without battery, with variable external power supply, start- ing with 1.55 V, lower tension until movement stops.	
	10 μA	$\leq 1,30 \mu\text{A}$	Consommation du mouvement. Stromaufnahme Uhrwerk. Consumption of movement.	Mesure sans pile, avec alimentation extérieure 1,55 V. Messung ohne Batterie, mit Spei- segerät 1,55 V. Measurement without battery, with external power supply 1.55 V.

Position Messpunkt Position	Echelle de mesure Einstellung Messgerät Setting of apparatus	Mesure Messung Measurement	Contrôle Kontrolle Test	Remarques Bemerkungen Remarks
3		$\leq 0,5 \mu\text{A}$	Fonctionnement de l'interrupteur en pos. 3 de la tige de mise à l'heure. Funktion des Stophebels, Pos. 3 der Zeigerstellwelle. Function of stop lever, pos. 3 of handsetting.	Mesure sans pile, avec alimentation extérieure 1,55 V. Messung ohne Batterie, mit Speisegerät 1,55 V. Measurement without battery, with external power supply 1.55 V.
4	10 k Ω 200 μA	1,3–1,8 k Ω 110–155 μA	Résistance de la bobine moteur. Widerstand der Motorspule. Resistance of motor coil.	
<p>Ohmmètres avec tension de mesure supérieure à 0,40 V inappropriés, tension recommandée 0,20 V. ~ Ohmmeter mit Prüfspannung über 0,40 V ungeeignet, empfohlene Spannung 0,20 V. Ohmmeter with a test voltage higher than 0.40 V unsuitable, recommended voltage 0.20 V.</p>				

*Les tests doivent être effectués dans une température ambiante entre 20° C et 25° C.
 Die Tests sind bei einer Umgebungstemperatur zwischen 20° C und 25° C durchzuführen.
 The tests must be conducted at an ambient temperature of between 20° C and 25° C.*



Pour des informations concernant les aiguillages voir:

Information Habillage

Plan:
AIGUILLAGES
ZEIGERWERKHÖHEN
HAND FITTING HEIGHTS



Für Informationen betreffend der Zeigerwerkhöhen siehe:

Fabrikanten Information

Zeichnung:
AIGUILLAGES
ZEIGERWERKHÖHEN
HAND FITTING HEIGHTS



For information regarding hand fitting heights see:

Manufacturing Information

Drawing:
AIGUILLAGES
ZEIGERWERKHÖHEN
HAND FITTING HEIGHTS

Cette page est laissée vide
intentionnellement en cas d'impression
au format A3.

Diese Seite wird absichtlich leer
gelassen für den Fall, dass im
A3-Format gedruckt wird.

This page has deliberately been
left blank in case of A3 format
printing.

**Modifications comparées aux versions
précédentes du document****Änderungen gegenüber vorher-
gehenden Dokumentversionen****Modifications compared with previous
document versions**

Version	Date Datum Date	Modification	Änderung	Modification	Page Seite Page
09	06.02.2015	Nouvelle adresse	Neue Adresse	New address	1, 4, 16
08	31.08.2010	Correction de la hauteur sur pile	Korrektur der Höhe über Batterie	Correction of the height over battery	1
07	27.04.2010	Suppression de la pièce 405/4	Teil Nr. 405/4 entfernt	Remove part No 405/4	3, 5
		Ajout lubrification sur dessin	Zusatz Schmierung auf Zeichnung	Addition lubrication on drawing	6, 8
		Suppression lubrifications	Schmierungen entfernt	Removal of lubricants	10
06	05.03.2010	Ajout lubrification sur dessin	Zusatz Schmierung auf Zeichnung	Addition lubrication on drawing	6
		Suppression lubrification (pièces No 2543 et 2555)	Schmierung entfernt (Teile Nr. 2543 und 2555)	Abolition of the lubrication (parts No 2543 and 2555)	8
05	24.08.2009	Modification lubrification	Änderung Schmierung	Modification lubrication	6
		Nouveau layout	Neues Layout	New layout	1-12
		Répartition des calibres	Aufteilung pro Kaliber	Allocation per caliber	--

Sous réserve de toutes modifications.

Änderungen vorbehalten.

All modifications reserved.

**Ce document se trouve sur le
Support Center Portal (SCP) :****www.eta.ch**

- Support Center
- Support Center Portal
- Documents techniques

**Dieses Dokument finden Sie im
Support Center Portal (SCP):****www.eta.ch**

- Support Center
- Support Center Portal
- Technische Dokumente

**This document can be found on the
Support Center Portal (SCP):****www.eta.ch**

- Support Center
- Support Center Portal
- Technical Documents

**ETA**^{SA}MANUFACTURE HORLOGÈRE SUISSE
DEP. N. 5.1793

SC PRODUCT COMMUNICATION

Bahnhofstrasse 9
2540 Grenchen
SwitzerlandPhone +41 (0)32 655 71 11
Fax +41 (0)32 655 71 74contact@eta.ch
www.eta.ch



11 1/2" ETA 955.132

CT 955132 ESI 491863 09 06.02.2015

11 1/2" Ø 25,60 mm

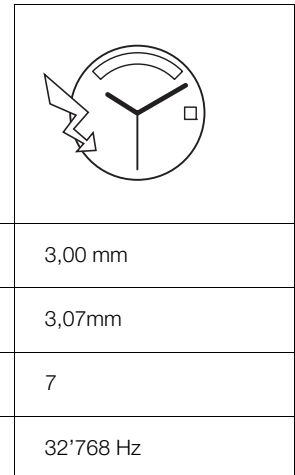

Movement height	Altura sobre máquina	Altezza sopra movimento	3,00 mm
Height on battery	Altura sobre pila	Altezza sopra pila	3,07mm
Number of jewels	Número de piedras	Numero di pietre	7
Frequency	Frecuencia	Frequenza	32'768 Hz

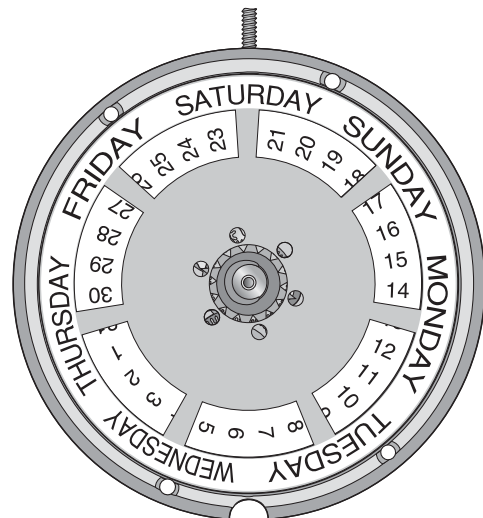
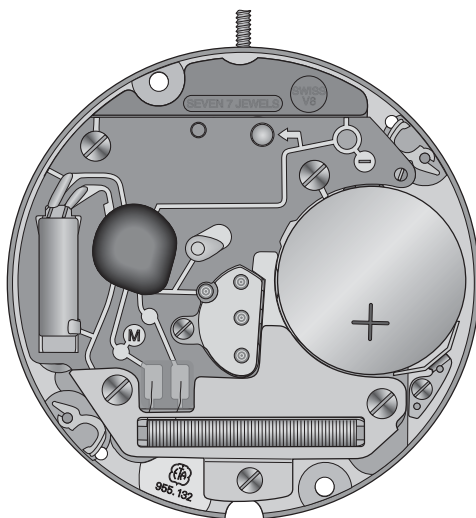

The repair and reconditioning work must only be performed by properly trained personnel.
Las tareas de reparación y revisión sólo deben ser llevadas a cabo por personal debidamente formado.
I lavori di riparazione e di revisione devono essere eseguiti esclusivamente da personale adeguatamente formato.



General information



Before starting work, please study this "Technical communication" carefully.



Eye protection is obligatory for all operations / work on the movement!



ETA SA disclaims any liability in case of damage arising from failure to observe this "Technical communication".

Environmental protection requirements



The legal provisions relating to waste handling and disposal must be observed in all operations / work on the movement!

In particular, lubricating and cleaning products harmful to the environment must be disposed of in accordance with the rules!



Substances prone to cause water pollution must be stored, transported, collected and disposed of in appropriate vessels.

Under no circumstances must they pollute the soil or be poured into sewage systems!

Explanation of symbols



Caution! Risk of material damage!

Below are some obligatory instructions for preventing any material damage!



Below is some advice for use and important information.

Información general



Esta "Comunicación técnica" deberá estudiarse muy bien **antes** de comenzar los trabajos.



Es obligatorio utilizar protección ocular para todos los trabajos en y con el reloj.



ETA SA no se hace responsable de los daños provocados como consecuencia de la inobservancia de esta "Comunicación técnica".

Normas de protección medioambiental



Deberá cumplirse la normativa legal relativa al reciclaje y la eliminación correctos de los residuos en todos los trabajos en y con el reloj.

En especial, deberán eliminarse correctamente los productos lubricantes y de limpieza peligrosos para el medio ambiente.



Las sustancias contaminantes del agua deben recogerse, almacenarse, transportarse y eliminarse en recipientes adecuados.

En ningún caso se permitirá que contaminen el suelo o que lleguen a la canalización.

Significado de los símbolos



Atención Peligro de daños materiales

Instrucciones que deberán respetarse necesariamente para evitar daños materiales.



Consejos de aplicación e información importantes.

Informazioni generali



Questa "Comunicazione Tecnica" deve essere studiata attentamente **prima** dell'inizio dei lavori.



Per tutti i lavori su e con il movimento dell'orologio è obbligatorio proteggere gli occhi!



ETA SA declina qualunque responsabilità per eventuali danni causati dalla mancata osservanza della presente "Comunicazione tecnica".

Disposizioni relative alla protezione ambientale



Per tutti i lavori su e con il movimento dell'orologio si dovranno rispettare le disposizioni di legge relative al corretto riciclaggio e smaltimento dei rifiuti!

In particolare si dovrà provvedere al corretto smaltimento di lubrificanti e detergenti nocivi per l'ambiente!



Le sostanze inquinanti per l'acqua devono essere conservate, trasportate, raccolte e smaltite in contenitori adatti.

Queste non devono inquinare il terreno o arrivare nelle canalizzazioni!

Spiegazione dei simboli



Attenzione! Pericolo di danni materiali!

Seguono importanti indicazioni che devono essere tassativamente rispettate per evitare danni materiali!



Seguono consigli per l'uso e informazioni importanti.

List of components - Lista de piezas - Lista fornitori

Pos	No	No CS	Article number Número de artículo Numero articolo		List of components	Lista de piezas	Lista fornitori
-	100	10.020.07	-		Main plate, jewelled	Platina, empedrada	Piastra con pietre
-	110	10.048.07	Var		Train wheel bridge, jewelled	Puente de rodaje empedrado	Ponte del ruotismo con pietre
-	144	10.300.00	-		Dial fastener	Sujetador de esfera	Ferma-quadrante
-	145	10.106.00	-		Dial support	Soporte del cuadrante	Supporto del quadrante
-	147	10.280.00	-		Mark support	Porta-marca	Porta-marchio
-	161	80.400.00	-		Centre tube	Tube de centro	Tube di centro
-	203	30.012.00	-		Intermediate wheel	Rueda intermedia	Ruota intermedia
-	210	30.025.00	-		Third wheel	Rueda primera	Ruota mediana
-	227	30.027.00	Var		Second wheel	Rueda de segundos	Ruota dei secondi
-	242	31.083.00	Var		Cannon pinion with driving wheel	Cañón de minutos con arrastrador	Pignone calzante con conduttore
-	255	31.046.00	Var		Hour wheel	Rueda de horas	Ruota delle ore
-	260	31.041.00	-		Minute wheel	Rueda de minutería	Ruota della minuteria
-	405	51.020.21	Var		Handsetting stem	Tija de puesta en hora	Albero di messa all'ora
-	407	31.121.00	-		Sliding pinion	Piñón corredizo	Pignone scorrevole
-	435	51.050.00	-		Yoke	Báscula de piñón corredizo	Bascula del pignone scorrevole
-	443/1	51.080.06	-		Setting lever, assembled	Tirete, montado	Tiretto, montato
-	445	51.090.00	-		Setting lever jumper	Muelle flexible de tirete	Scatto del tiretto
-	450	31.100.00	-		Setting wheel	Rueda de transmisión	Rinvio
-	462	10.062.00	-		Minute train bridge	Puente de rodaje de minutería	Ponte del ruotismo di minuteria
-	549	81.185.00	-		Setting lever spring-clip	Chaveta de tirete	Chivetta del tiretto
-	560	56.071.00	-		Stop lever and switch	Palanca de parada e interruptor	Leva di arresto e interruttore
-	2543	33.011.00	-		Intermediate date wheel	Rueda intermedia de fecha	Ruota intermedia del datario
-	2555	33.028.00	-		Calendar driving wheel	Rueda de arrastre del calendario	Ruota conduttrice del calendario
-	2557/1	91.440.22	Var		Date indicator, for window opening at 3 'clock	Indicador de fecha, para abertura de ventanilla en las 3 horas	Indicatore della data, apertura della data ore 3
-	2561/1	91.441.21	Var		Day indicator, for circular arc opening at 12 o'clock	Indicador del día, para abertura en arco de círculo en las 12 horas	Indicatore del giorno, per apertura arco di cerchio sulle ore 12
-	2567	53.201.00	-		Day corrector	Corrector del día	Correttore dei giorni
-	2569	53.204.00	-		Double corrector	Corrector doble	Correttore doppio
-	2570	53.026.00	-		Double corrector operating lever	Mando del corrector doble	Comando del correttore doppio
-	2573	63.032.00	-		Day jumper spring	Resorte del muelle flexible de días	Molla dello scatta-giorni
-	2576	53.080.00	-		Date jumper	Muelle flexible de fecha	Scatta-data
-	2577	53.081.00	-		Day jumper	Muelle flexible de días	Scatta-giorni
-	2595	13.111.00	-		Date jumper maintaining plate	Placa de sujeción del muelle flexible de fecha	Placca di guardia dello scatta-data
-	2780	83.171.00	-		Day indicator spring-clip	Chaveta del indicador del día	Chivetta dell'indicatore dei giorni
-	4000	10.513.00	Var		Electronic module	Módulo electrónico	Modulo elettronico
-	4021	20.582.00	-	3x	Stator	Estátor	Statore
-	4022	80.102.00	Var		Distance piece	Tirante del módulo electrónico	Spessore del modulo elettronico
-	4038	20.584.00	-		Upper magnetic screen	Pantalla magnética superior	Schermo magnetico superiore
-	4046	20.651.00	-		Battery insulator	Aislante de pila	Isolatore della pila
-	4211	20.580.00	-		Rotor	Rotor	Rotore
-	4233	80.246.00	-		Rivet for stator	Remache del estátor	Ribattino dello statore
-	4407	20.764.00	-		Bridle +	Brida de masa	Brida della massa
-	4412	10.601.00	-		Battery limiting spring	Muelle de limitación de pila	Molla di limitazione della pila
-	4929	20.570.00	Var		Battery	Pila	Pila
-	5110	10.048.01	Var	1x	Screw for train wheel bridge	Tornillo de puente de rodaje	Vite del ponte del ruotismo
1)	5462	10.062.01	-	1x	Screw for minute train bridge	Tornillo para puente del rodaje de minutería	Vite per ponte del ruotismo di minuteria
-	52567	53.201.01	-	1x	Screw for day corrector	Tornillo para correctora del día	Vite per correttore dei giorni
1)	52573	63.032.01	-	1x	Screw for day jumper spring	Tornillo para resorte del muelle flexible de días	Vite per molla dello scatta-giorni
1)	52595	13.111.01	-	1x	Screw for date jumper maintaining plate	Tornillo de placa de sujeción del muelle flexible de fecha	Vite della placca di guardia dello scatta-data
-	54000	10.513.02	Var	4x	Screw for electronic module, long	Tornillo de módulo electrónico, largo	Vite del modulo elettronico, lunga
-	54000'	10.513.02	Var	1x	Screw for electronic module, short	Tornillo de módulo electrónico, corto	Vite del modulo elettronico, corta
2)	54038	20.584.01	-	1x	Screw for upper magnetic screen	Tornillo para pantalla magnética superior	Vite per schermo magnetico superiore
2)	54407	20.764.01	-	1x	Screw for earth connector	Tornillo de brida de masa	Vite della brida della massa

Pos	No	No CS	Article number Número de artículo Numero articolo	List of components	Lista de piezas	Lista fornitori
				Identical screws Tornillos idénticos Viti identiche	1) 5462 52573 52595	2) 54038 54407

**Interchangeability and variants
can be found on the
ETA ONLINE SHOP (EOS):**

www.eta.ch
→ Support Center
→ Support Center Portal

**La intercambiabilidad y las
variantes se encuentran en
ETA ONLINE SHOP (EOS):**

www.eta.ch
→ Support Center
→ Support Center Portal

**L'intercambiabilità e le varianti si
trovano sul
ETA ONLINE SHOP (EOS):**

www.eta.ch
→ Support Center
→ Support Center Portal

Materials - Fornituras - Forniture

										5110 Var	
100	110 Var	144	145	147	161	203	210	227 Var			
											5462 52595
242 Var	255 Var	260	405 Var	407	435	443/1	445	450	462	549	
											52567
560	2543	2555	2557/1 Var	2561/1 Var	2567	2569	2570	2573	2576		52573
											54000 Var
2577	2595	2780	4000 Var	4021	4022 Var	4038	4046	4211			
											54000 ¹ Var 54038 54407
4233	4407	4412	4929 Var								

Order of assembly - Orden del montaje - Ordine dell'assemblaggio:
 Basic movement - Máquina de base - Movimento di base

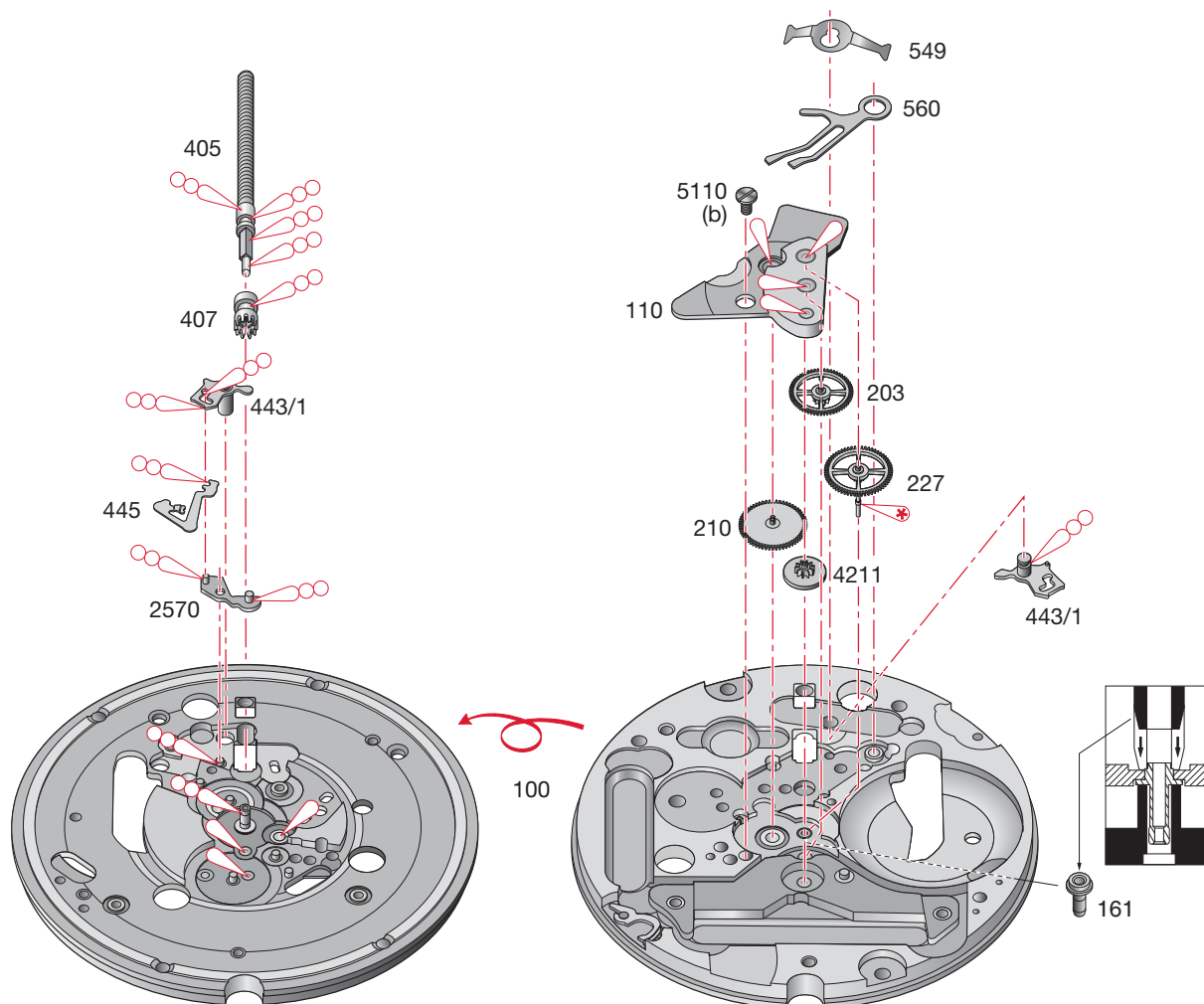

Assembling of the basic movement

(Parts listed in order of assembly)

Montaje de la máquina de base

(Lista de fornituras por orden de ensamblado)

Montaggio del movimento di base

(Elenco delle forniture in ordine di montaggio)

100	443/1	560
161	549	110
407	210	5110 (1x)
405	4211	
2570	227	
445	203	

Lubrication - Lubricación - Lubrificazione

 Fine oil
Aceite fino
Olio fluido

Moebius 9014

or / ó / o

Moebius 9034

 Thick oil or grease
Aceite espeso o grasa
Olio denso o grasso

Moebius**HP-1300**

or / ó / o

Moebius D5

 Very small quantity
Cantidad muy pequeña
Piccolissima quantità

Moebius 9014

or / ó / o

Moebius 9034**M_L Minimum torque for loosening****M_L Par mínimo para desatornillar****M_L Coppia minima per svitare**

(b) 0,7 Ncm

Order of assembly - Orden del montaje - Ordine dell'assemblaggio:
 Handsetting and the calendar mechanisms - Mecanismo de puesta en hora y de calendario - Meccanismo della messa all'ora e del calendario

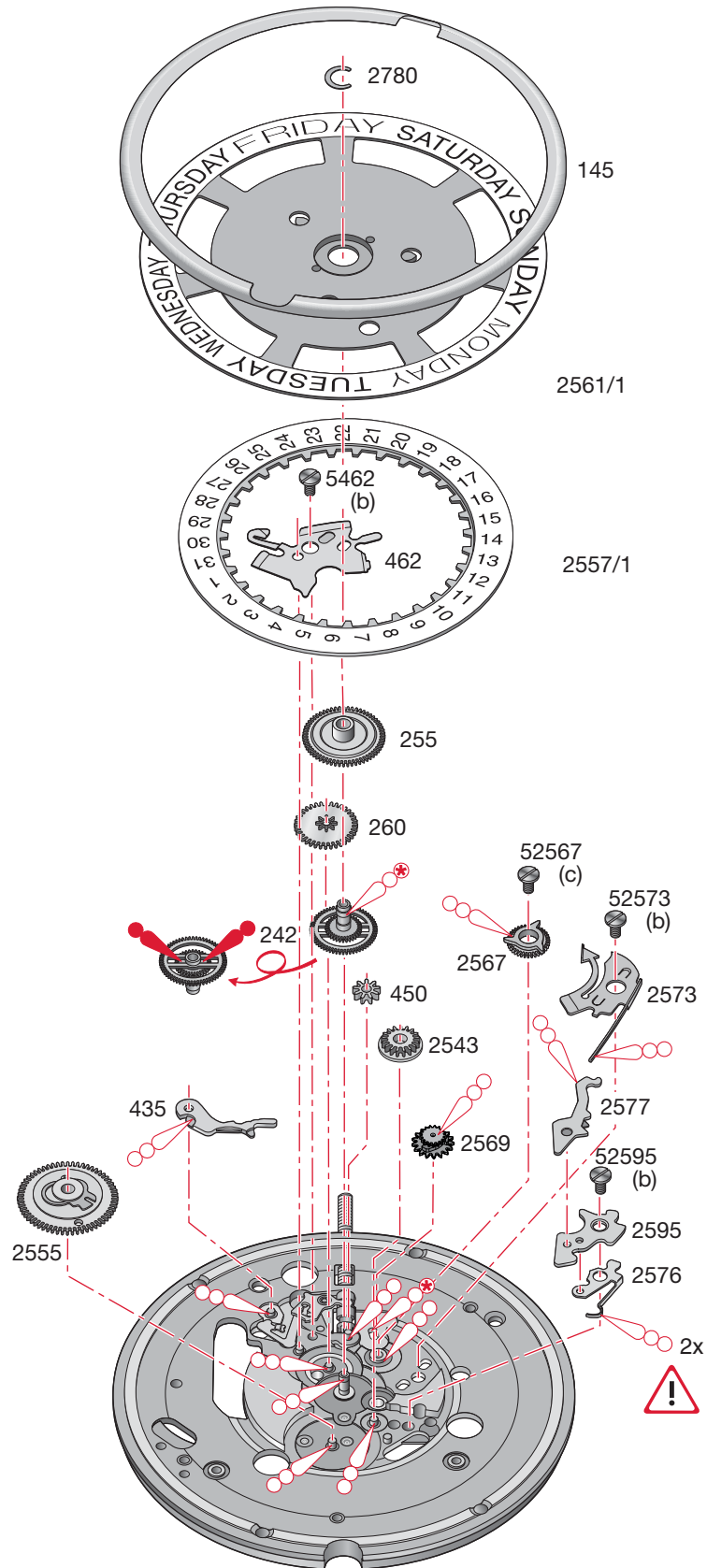

Assembling of the handsetting and the calendar mechanism

(Parts listed in order of assembly)

Montaje del mecanismo de puesta en hora y del mecanismo de calendario



(Lista de fornitureas por orden de ensamblado)

Montaggio della messa all'ora e del meccanismo del calendario

(Elenco delle forniture in ordine di montaggio)

242	5462 (1x)	2573
260	2557/1	52573 (1x)
450	2555	2577
2569	2543	5461/1
2567	2576	2780
52567 (1x)	2595	145
435	52595 (1x)	
462	255	

Lubrication - Lubricación - Lubrificazione

	Thick oil or grease Aceite espeso o grasa Olio denso o grasso	Moebius HP-1300 or / ó / o Moebius D5
	Grease Grasa Grasso	Moebius 9501 or / ó / o Jismaa 124
	Very small quantity Cantidad muy pequeña Piccolissima quantità	Moebius HP-1300 or / ó / o Moebius D5

M_L Minimum torque for loosening**M_L Par mínimo para desatornillar****M_L Coppia minima per svitare**

(b) 0,7 Ncm

	Lubricate part 2576. 1. Lubrique la pieza 2576. Lubrificare il pezzo 2576.
	Rotate part 2557/1 approx 10 teeth with rapide correction. 2. Gire la pieza 2557/1 unos 10 dientes con la corrección rápida. Ruotare il pezzo 2557/1 di circa 10 denti con la correzione rapida.
	Lubricate again part 2576. 3. Lubrique de nuevo la pieza 2576. Lubrificare di nuovo il pezzo 2576.
	Rotate part 2557/1 approx 10 teeth with rapide correction again. 4. Gire de nuevo la pieza 2557/1 unos 10 dientes con la corrección rápida. Ruotare di nuovo il pezzo 2557/1 di circa 10 denti con la correzione rapida.

Order of assembly - Orden del montaje - Ordine dell'assemblaggio:
 Basic movement and the electronic module - Máquina de base y del módulo electrónico - Movimento di
 base e del modulo elettronico

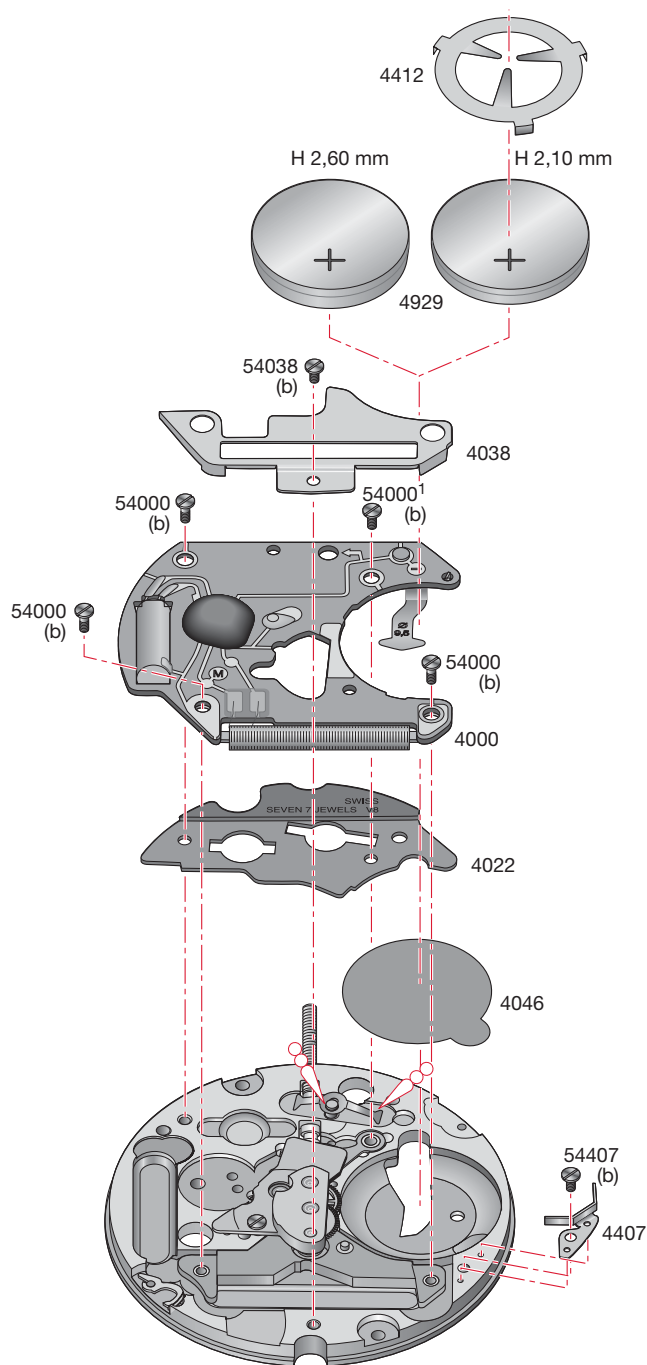

Assembling of the basic movement and the electronic module

(Parts listed in order of assembly)

Montaje de la máquina de base y del módulo electrónico

(Lista de fornitureas por orden de ensamblado)

Montaggio del movimento di base e del modulo elettronico

(Elenco delle forniture in ordine di montaggio)

4407	54000 ¹ (1x)	
54407 (1x)	4038	
4022	54038 (1x)	
4046	4929	
4000	4412	
54000 (3x)		

Lubrication - Lubricación - Lubrificazione

Thick oil or grease
 Aceite espeso o grasa
 Olio denso o grasso

Moebius
HP-1300
 or / ó / o
Moebius D5

M_L Minimum torque for loosening**M_L Par mínimo para desatornillar****M_L Coppia minima per svitare**

(b) 0,7 Ncm

4412:

To be fitted when the clearance between the movement and the case back is too great.



Necesario, si la seguridad entre el movimiento y el fondo de la caja es demasiado elevada.

Necessario quando la sicurezza tra il movimento e il fondo della cassa è troppo elevata.

Electrical tests - Controles eléctricos - Controlli elettrici

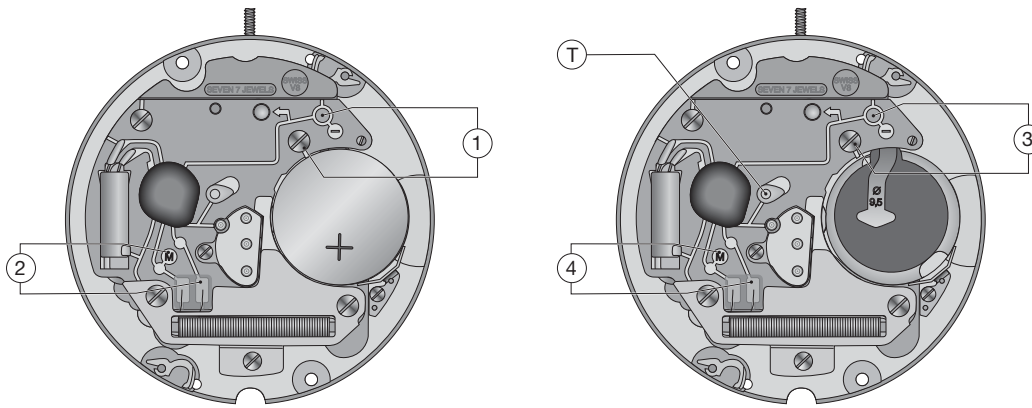

Position Posición Posizione	Setting of apparatus Escala de medición Scala di misura	Measurement Medición Misura	Test Control Controllo	Remarks Notas Osservazioni
1	2 V ($R_i \geq 10 \text{ k}\Omega/\text{V}$)	1,55 V	Battery voltage Tensión de la pila Tensione della pila	Measurement with battery. Medición con pila. Misura con pila.
	2 V	4 steps jump every 4 sec., when feed voltage < 1.30 V.	EOL function. End of life test for the battery.	Measurement without battery, with feed voltage < 1.30 V, EOL –function after about 2 min.
		Salto de 4 pasos cada 4 segundos, con tensión de alimentación < 1,30 V.	Función EOL. Prueba de indicación de fin de vida de la pila.	Medición sin pila, con tensión de alimentación < 1,30 V, EOL –funcionamiento después de 2 minutos.
Scatto di 4 passi ogni 4 secondi quando la tensione e di un'alimentazione < 1,30 V.	Funzione EOL. Prova dell'indicazione di fine vita della pila.	Misura senza pila, con tensione di alimentazione < 1,30 V, EOL –funzionamento dopo 2 minuti.		
2	1 V ($R_i \geq 10 \text{ k}\Omega / \text{V}$)	Hand of the measuring apparatus oscillates in + and – direction. La aguja del multímetro oscila en sentido + y –. La lancetta del multimetro oscilla nel senso + e –.	Impulses at output of integrated circuit: Frequency 1/s. Impulsos a la salida del circuito integrado: Frecuencia 1/s. Impulsi all'uscita del circuito integrato: Frequenza 1/s.	Measurement with controlled battery. Medición con pila controlada. Misura con pila controllata.
3	2 V 10 μA	$\leq 1,30 \text{ V}$ Connect T point with the – conductor. Motor driven with 8 steps/s at 1.55 V and 32 steps/s with voltage $\leq 1,30 \text{ V}$ (EOL). Conectar el punto T con la pista –. Mando del motor con 8 pasos/s a 1,55 V y 32 pasos/s con tensión $\leq 1,30 \text{ V}$ (EOL). Mettere in contatto il punto T con il punto –. Comando del motore con 8 passi/s a 32 passi/s con tensione $\leq 1,30 \text{ V}$ (EOL).	Lower working–voltage limit. Límite inferior de la tensión de funcionamiento. Limite inferiore della tensione di funzionamento.	Measurement without battery, with variable external power supply, starting with 1.55 V, lower tension until movement stops. Medición sin pila, con alimentación exterior variable bajando de 1,55 V hasta la parada de la máquina. Misura senza pila con alimentazione esterna variabile, scendendo da 1,55 V fino all'arresto del movimento.
		10 μA	$\leq 1,30 \mu\text{A}$	Consumption of movement. Consumo de la máquina. Consumo del movimento.

Position Posición Posizione	Setting of apparatus Escala de medición Scala di misura	Measurement Medición Misura	Test Control Controllo	Remarks Notas Osservazioni
3		$\leq 0,5 \mu\text{A}$	Function of stop lever, pos. 3 of handsetting. Funcionamiento del interruptor en pos. 3 de la tija de puesta en hora. Funzionamento dell'interruttore in pos. 3 dell'albero di massa all'ora.	Measurement without battery, with external power supply 1.55 V. Medición sin pila, con alimentación exterior de 1,55 V. Misura senza pila con alimentazione esterna di 1,55 V.
4	10 k Ω 200 μA	1,3–1,8 k Ω 110–155 μA	Resistance of motor coil. Resistencia de la bobina del motor. Resistenza della bobina motore.	
<i>Ohmmeter with a test voltage exceeding 0.40 V unsuitable, recommended voltage 0.20 V. Ohmiómetros con tensión de medición superior a 0,40 V inapropiados; tensión recomendada 0,20 V Ohmmetri con tensione di misura superiore a 0,40 V sono inadeguati; tensione raccomandata 0.20 V</i>				

*The test must be conducted at an ambient temperature of between 20°C and 25°C.
Las pruebas deben realizarse a una temperatura ambiente comprendida entre 20°C y 25°C.
I test devono essere effettuati a temperatura ambiente compresa tra 20°C e 25°C.*



For information regarding hand fitting heights see:

Manufacturing Information

Drawing:
AIGUILLAGES
ZEIGERWERKHÖHEN
HAND FITTING HEIGHTS



Para obtener información sobre las alturas de la minutería, consulte:

Información de la producción

Plan:
AIGUILLAGES
ZEIGERWERKHÖHEN
HAND FITTING HEIGHTS



Per informazioni concernenti l'aggiustamento lancette, consultare:

Informazione di produzione

Disegno:
AIGUILLAGES
ZEIGERWERKHÖHEN
HAND FITTING HEIGHTS

This page has deliberately been left blank in case of A3 format printing.

Esta página se han dejado en blanco a propósito en caso de imprimirla en formato A3.

Questa pagina è lasciata intenzionalmente bianca in caso di stampa formato A3.

Modifications compared with previous document versions**Modificaciones comparadas con las versiones anteriores del documento****Modifiche comparate con le versioni precedenti del documento**

Version Versión Version	Date Fecha Data	Modification	Modificación	Modifica	Page Página Pagina
09	06.02.2015	New adress	Nueva dirección	Nuovo indirizzo	1, 4, 16
08	31.08.2010	Correction of the height over battery	Corrección de la altura sobre pila	Correzione della altezza sopra la batteria	1
07	27.04.2010	Remove part No 405/4	Eliminar pieza No 405/4	Soppressione del pezzo No 405/4	3, 5
		Addition lubrication on drawing	Lubrificación adicional según dibujo	Aggiunta lubrificazione come sul disegno	6, 8
		Removal lubricants	Eliminar lubricación	Soppressione lubrificazione	10
06	02.03.2010	Addition lubrication on drawing	Lubrificación adicional según dibujo	Aggiunta lubrificazione come sul disegno	6
		Abolition of the lubrication (parts No 2543 and 2555)	Eliminar lubricación (piezas No 2543 y 2555)	Soppressione lubrificazione (pezzi No 2543 e 2555)	8
05	24.08.2009	Modification lubrication	Modificación lubricación	Modifica lubrificazione	6
		New layout	Nuevo layout	Nuovo layout	1-12
		Allocation per caliber	Asignación por calibre	Ripartizione per calibro	--

All modifications reserved.

Salvo modificación.

Con riserva di ogni eventuale modifica.

This document can be found on the
Support Center Portal (SCP):

www.eta.ch

- Support Center
- Support Center Portal
- Technical Documents

Este documento se encuentran en el
Support Center Portal (SCP):

www.eta.ch

- Support Center
- Support Center Portal
- Technical Documents

Il presente documento si trovano sul
Support Center Portal (SCP):

www.eta.ch

- Support Center
- Support Center Portal
- Technical Documents



ETA^{SA}
MANUFACTURE HORLOGÈRE SUISSE
DEPUI 1793

SC PRODUCT COMMUNICATION

Bahnhofstrasse 9
2540 Grenchen
Switzerland

Phone +41 (0)32 655 71 11
Fax +41 (0)32 655 71 74

contact@eta.ch
www.eta.ch