



10 ½''' ETA E63.041

CT E63041 FDE 535306 03 22.06.2015



10 ½''' Ø 23,30 mm

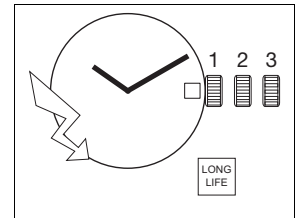

Hauteur sur mouvement	Höhe auf Werk	Movement height	1,95 mm
Hauteur sur pile	Höhe auf Batterie	Height on battery	No 373: 2,10 mm No 371: 2,50 mm
Nombre de rubis	Anzahl Rubine	Number of jewels	8
Fréquence	Frequenz	Frequency	32'768 Hz

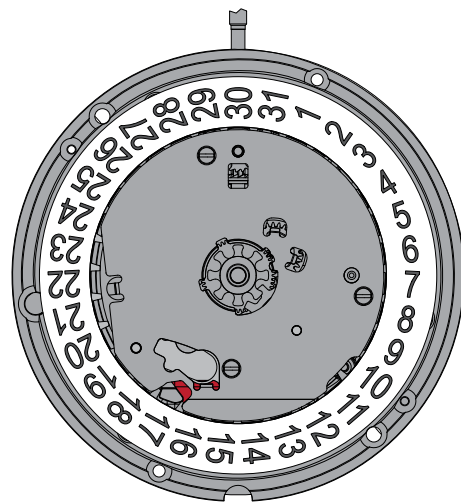
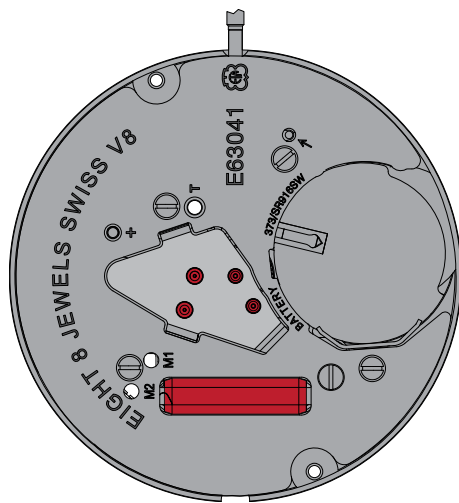

Les travaux de réparation et de révision ne doivent être effectués que par du personnel dûment formé.
Reparatur- und Revisionsarbeiten dürfen nur von ausgebildetem Fachpersonal ausgeführt werden.
The repair and reconditioning work must only be performed by properly trained personnel.



Informations générales



Avant de démarrer les travaux, veuillez svp étudier attentivement cette "Communication technique".



La protection des yeux est obligatoire pour toutes les interventions / tous les travaux sur le mouvement!



ETA SA décline toute responsabilité en cas de dommages du non respect de cette "Communication technique".

Exigences en matière de protection de l'environnement



Les dispositions légales en matière de traitement et d'élimination des déchets doivent être respectées lors de toutes les interventions / tous les travaux sur les mouvements!

En particulier, les produits de graissage et de nettoyage néfastes pour l'environnement doivent être éliminés selon les règles!



Les **substances de nature à polluer l'eau** doivent être entreposées, transportées, récupérées et éliminées dans des récipients adéquats.

Elles ne doivent en aucun cas polluer le sol ou être évacuées dans les réseaux de canalisation!

Explication des symboles



Ci-après quelques conseils d'utilisations et informations importantes.

Allgemeine Informationen



Diese "Technische Mitteilung" ist **vor** dem Beginn der Arbeiten genauestens zu studieren.



Für sämtliche Arbeiten am und mit dem Uhrwerk ist ein Augenschutz obligatorisch!



Für Schäden, welche durch Nichtbeachtung dieser "Technischen Mitteilung" entstehen, haftet die ETA SA nicht.

Umweltschutz-Vorschriften



Bei allen Arbeiten am und mit dem Uhrwerk sind die gesetzlichen Vorschriften zur ordnungsgemässen Verwertung und Beseitigung der Abfälle einzuhalten!

Insbesondere sind umweltgefährdende Schmier- und Reinigungsmittel ordnungsgemäss zu entsorgen!



Wassergefährdende Stoffe müssen in geeigneten Behältern aufbewahrt, transportiert, aufgefangen und entsorgt werden.

Diese dürfen nicht den Boden belasten oder in die Kanalisation gelangen!

Symbolerklärung



Hier folgen Anwendungstipps und wichtige Informationen.

General information



Before starting work, please study this "Technical communication" carefully.



Eye protection is obligatory for all operations / work on the movement!



ETA SA disclaims any liability in case of damage arising from failure to observe this "Technical communication".

Environmental protection requirements



The legal provisions relating to waste handling and disposal must be observed in all operations / work on the movement!

In particular, lubricating and cleaning products harmful to the environment must be disposed of in accordance with the rules!



Substances prone to cause water pollution must be stored, transported, collected and disposed of in appropriate vessels.

Under no circumstances must they pollute the soil or be poured into sewage systems!

Explanation of symbols



Below is some advice for use and important information.

Liste des fournitures - Bestandteilliste - List of components

Pos	Numéro d'article Artikelnummer Article number	Liste des fournitures	Bestandteilliste	List of components
1	Var	Platine, montée	Werkplatte, montiert	Main plate, assembled
2	7613226088788	Pignon coulant	Kupplungstrieb	Sliding pinion
3	7613226088474	Tige de mise à l'heure	Stellwelle	Handsetting stem
4	7613226088795	Bascule de pignon coulant	Kupplungstriebhebel	Yoke
5	7613226088801	Tirette, montée	Winkelhebel, montiert	Setting lever, assembled
6	7613226088818	Sautoir de tirette	Winkelhebelraste	Setting lever jumper
7	7613226088832	Renvoi de mise à l'heure	Zeiteinstellgetriebe	Time setting gear
8	7613226088849	Entretoise de bride -	Zwischenstück für Bügel -	Distance piece for bridle -
9	7613226088856	Stator	Stator	Stator
10	7613226088863	Rotor	Rotor	Rotor
11	7613226118119	Roue intermédiaire	Zwischenrad	Intermediate wheel
12	7613226088887	Roue moyenne	Kleinbodenrad	Third wheel
13	7613226118102	Roue de seconde sans sec.	Sekundenrad ohne Sekunde	Second wheel without sec.
14	Var	Pont de rouage, empierré	Räderwerkbrücke, mit Steinen	Train wheel bridge, jewelled
15	7613226088467	Bobine, montée	Spule, montiert	Coil, assembled
16	7613226088931	Bride +	Bügel +	Bridle +
17	7613226088948	Isolateur de pile	Isolation für Batterie	Battery insulator
18	Var	Module électronique	Elektronik-Baugruppe	Electronic module
19	7613226139237	Couvre-module électronique	Halteplatte für Elektronik-Baugruppe	Electronic module cover
20	Var	Chaussée avec roue entraîneuse	Minutenrohr mit Antriebsrad	Cannon pinion with driving wheel
21	7613226086418	Roue de minuterie, montée	Wechselrad, montiert	Minute wheel, assembled
22	Var	Indicateur de quantième	Datumanzeiger	Date indicator
23	Var	Roue des heures, montée	Stundenrad, montiert	Hour wheel, assembled
24	Var	Roue entraîneuse de l'indicateur de quantième	Datumanzeiger-Mitnehmerrad	Date indicator driving wheel
25	7613226086449	Correcteur de quantième	Datumkorrektor	Date corrector
26	7613226086456	Sautoir de quantième	Datumraste	Date jumper
27	Var	Plaque de maintien du mécanisme de calendrier	Halteplatte für Kalender-Mechanismus	Calendar mechanism maintaining plate
28	7613226086463	Ressort du sautoir de quantième	Feder für Datumraste	Date jumper spring
29	Var	Pile	Batterie	Battery
30	7613226018242	Ressort de limitation de pile	Begrenzungsfeder für Batterie	Battery limiting spring
900	7613226086524	1x Vis à tête cylindrique - Pos. 8: Vis d'entretoise de bride - 1x - Pos. 14: Vis de pont de rouage 1x - Pos. 16: Vis de bride +	Zylinderschraube - Pos. 8: Schraube für Zwischenstück für Bügel - - Pos. 14: Schraube für Räderwerkbrücke - - Pos. 16: Schraube für Bügel +	Cylindrical head screw - Pos. 8: Screw for distance piece for bridle - - Pos. 14: Screw for train wheel bridge - Pos. 16: Screw for bridle +
901	7613226086531	3x Vis à tête conique - Pos. 19: Vis de couvre-module électronique	Senkschraube - Pos. 19: Schraube für Halteplatte für Elektronik-Baugruppe	Countersunk head screw - Pos. 19: Screw for electronic module cover
902	7613226086548	1x Vis à portée - Pos. 19: Vis de couvre-module électronique	Ansatzschraube - Pos. 19: Schraube für Halteplatte für Elektronik-Baugruppe	Shouldered flat head screw - Pos. 19: Screw for electronic module cover
903	7613226086555	3x Vis à tête conique - Pos. 27: Vis de plaque de maintien du mécanisme calendrier	Senkschraube - Pos. 27: Schraube für Halteplatte für Kalender-Mechanismus	Countersunk head screw - Pos. 27: Screw for Calendar mechanism maintaining plate
	Var	Variante	Variante	Variant

L'interchangeabilité et les variantes se trouvent sur ETA ONLINE SHOP (EOS) :

www.eta.ch
→ Support Center
→ Support Center Portal

Die Austauschbarkeit und Varianten finden Sie im ETA ONLINE SHOP (EOS):

www.eta.ch
→ Support Center
→ Support Center Portal

Interchangeability and variants can be found on the ETA ONLINE SHOP (EOS):

www.eta.ch
→ Support Center
→ Support Center Portal

Fournitures - Bestandteile - Materials

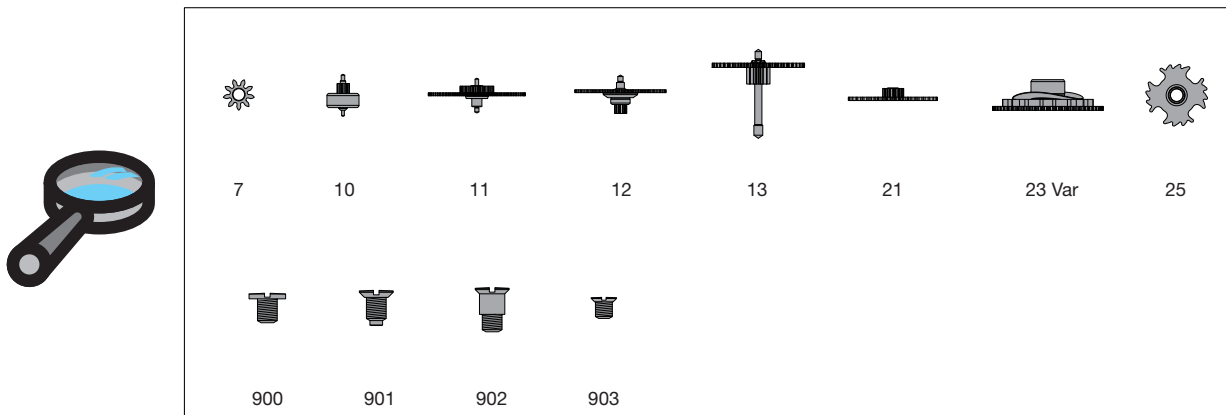
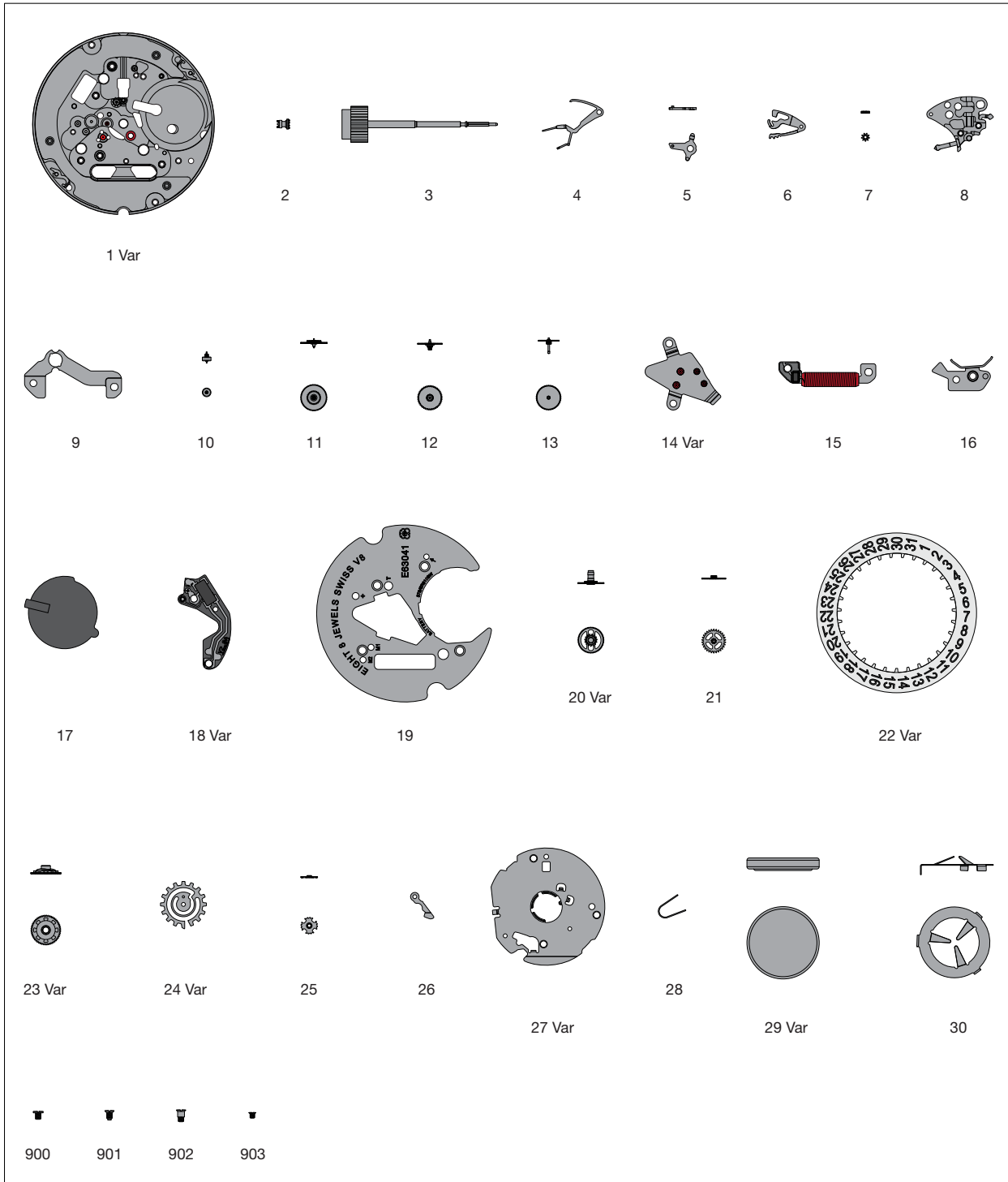

Ordre d'assemblage - Montager Reihenfolge - Order of assembly:
 Mouvement de base - Basiswerk - Basic movement

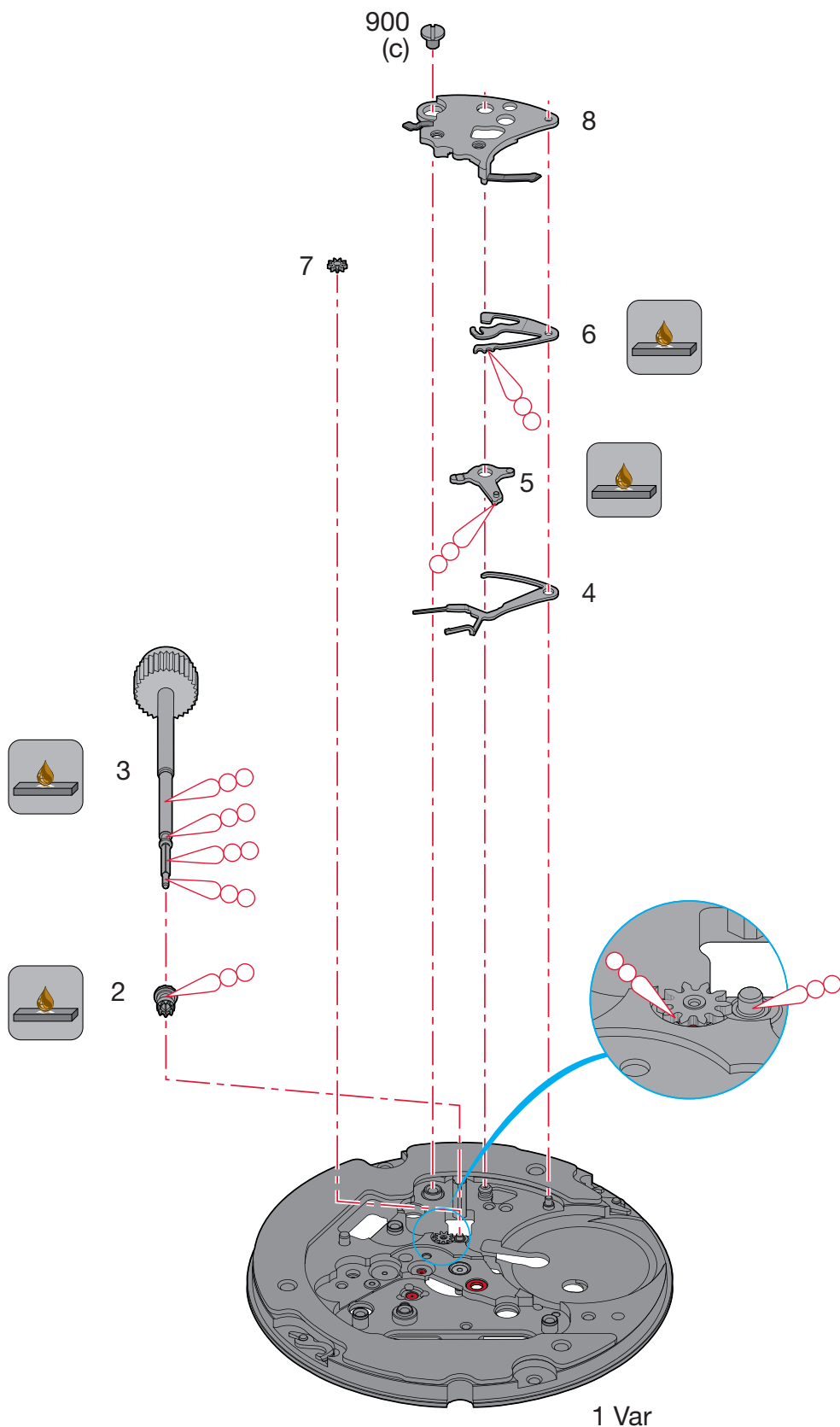

Montage du mouvement de base

(Liste des fournitures par ordre d'assemblage)

Zusammenstellen des Basiswerkes

(Bestandteilliste in Montagereihenfolge)

Assembling of the basic movement

(Parts listed in order of assembly)

1 Var	5	900 (1x)
2	6	
3	7	
4	8	

Lubrification - Schmierung - Lubrication



Huile épaisse ou graisse
Dickflüssiges Öl oder Fett
Thick oil or grease

**Moebius
HP-1300**
ou / oder / or
Moebius D5

Si les pièces à assembler ne sont pas neuves, les composants existants doivent être traités à la Moebius Fixodrop FK/BS 8941 avant le réassemblage.



Wenn keine Neuteile montiert werden, müssen die vorhandenen Teile vor der Wiedermontage mit Moebius Fixodrop FK/BS 8941 epilamisiert werden.

If the pieces to be assembled are not new, existing components must be treated with Moebius Fixodrop FK/BS 8941 epilame before reassembly.

Moebius Fixodrop FK/BS 8941



Volatile
Flüchtig
Volatile

Produit très volatile!

À garder après usage dans des récipients fermés et étanches.

Sehr flüchtiges Produkt!

Nach Gebrauch in geschlossenen und luftdichten Behältern aufbewahren.

Very volatile product!

Keep in closed and airtight containers after usage.

M_L Couple minimum pour dévisser

M_L Minimales Drehmoment zum Lösen

M_L Minimum torque for loosening

(c) 0,8 Ncm

Ordre d'assemblage - Montagerihenfolge - Order of assembly:
Rouage - Räderwerk - Wheel train

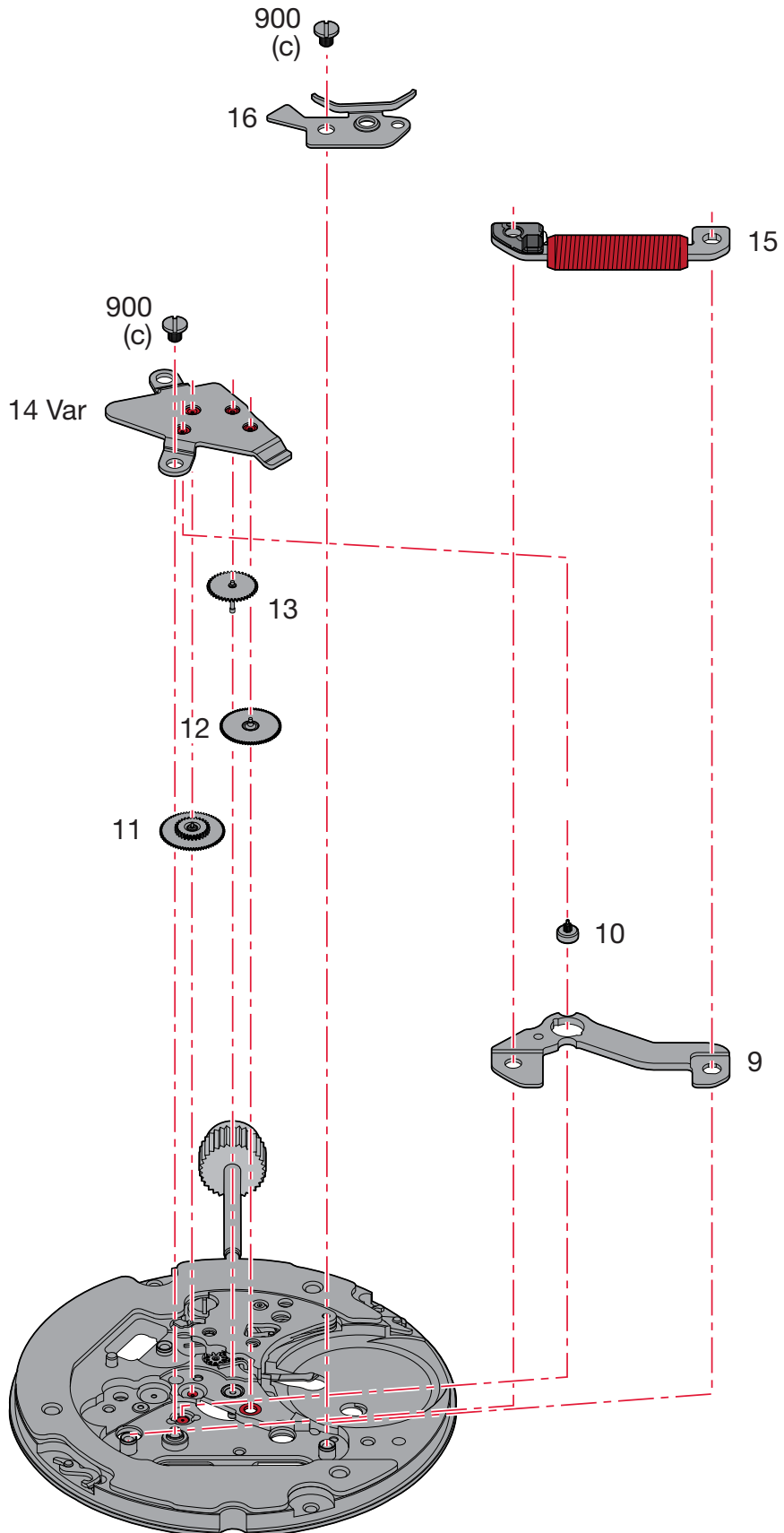

Montage du rouage

(Liste des fournitures par ordre d'assemblage)

Zusammenstellen des Räderwerks

(Bestandteilliste in Montagereihenfolge)

Assembling of the wheel train

(Parts listed in order of assembly)

9	13	16
10	14 Var	900 (1x)
11	900 (1x)	
12	15	

M_L Couple minimum pour dévisser**M_L Minimales Drehmoment zum Lösen****M_L Minimum torque for loosening**

(c) 0,8 Ncm

Ordre d'assemblage - Montager Reihenfolge - Order of assembly:
Module électronique - Elektronik-Baugruppe - Electronic module

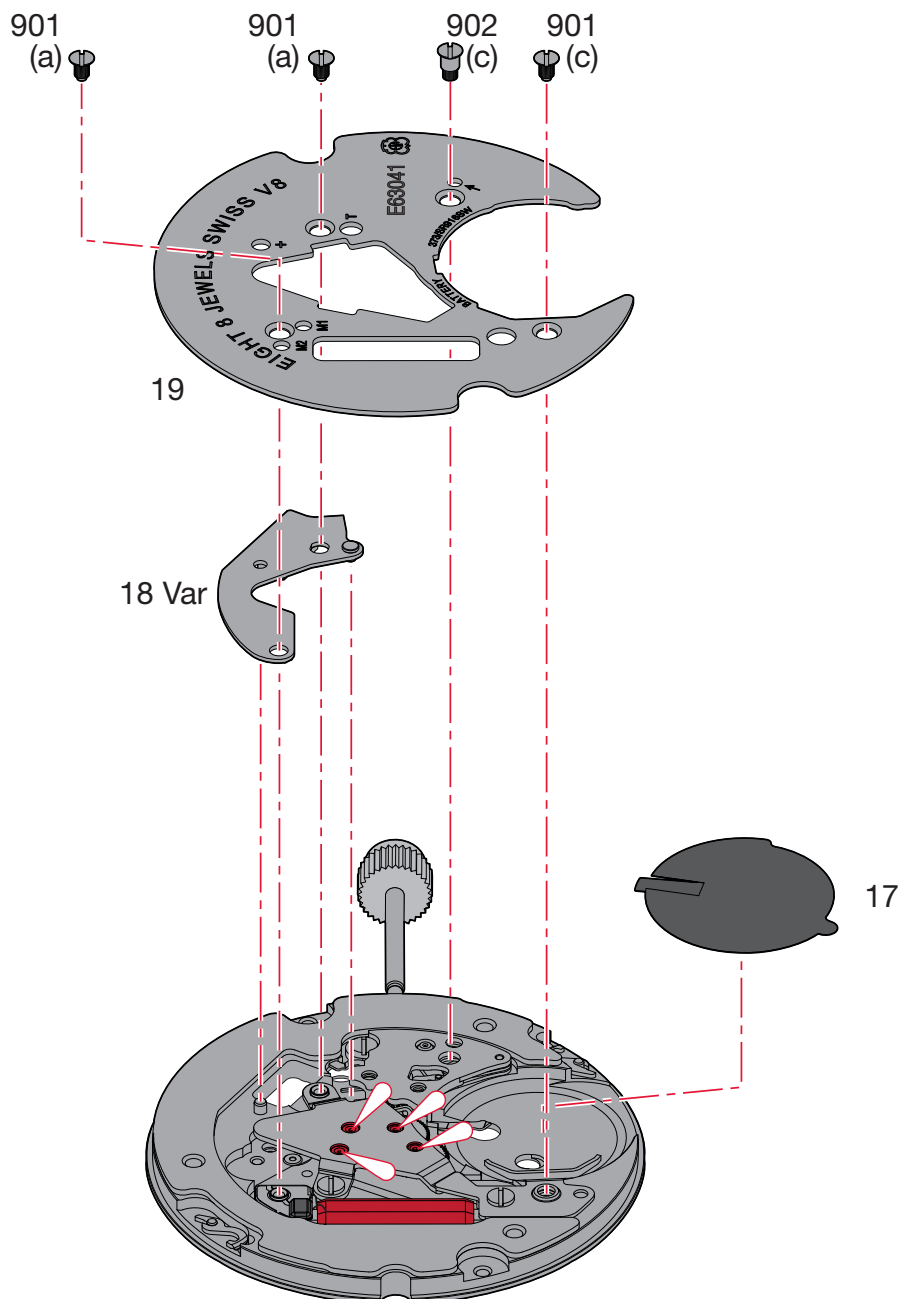

Montage du module électronique

(Liste des fournitures par ordre d'assemblage)

Zusammenstellen der Elektronik-Baugruppe

(Bestandteilliste in Montager Reihenfolge)

Assembling of the electronic module

(Parts listed in order of assembly)

17	901 (3x)	
18 Var	902 (1x)	
19		

Lubrification - Schmierung - Lubrication

 Huile fine
Dünnflüssiges Öl **Moebius 9014**
Fine oil

M_L Couple minimum pour dévisser**M_L Minimales Drehmoment zum Lösen****M_L Minimum torque for loosening**

- (a) 0,5 Ncm
- (c) 0,8 Ncm

Ordre d'assemblage - Montagereihenfolge - Order of assembly:
 Mécanisme de mise à l'heure et du mécanisme de calendrier - Zeigerwerkmechanismus und Kalendermechanismus - Handsetting mechanism and calendar mechanism

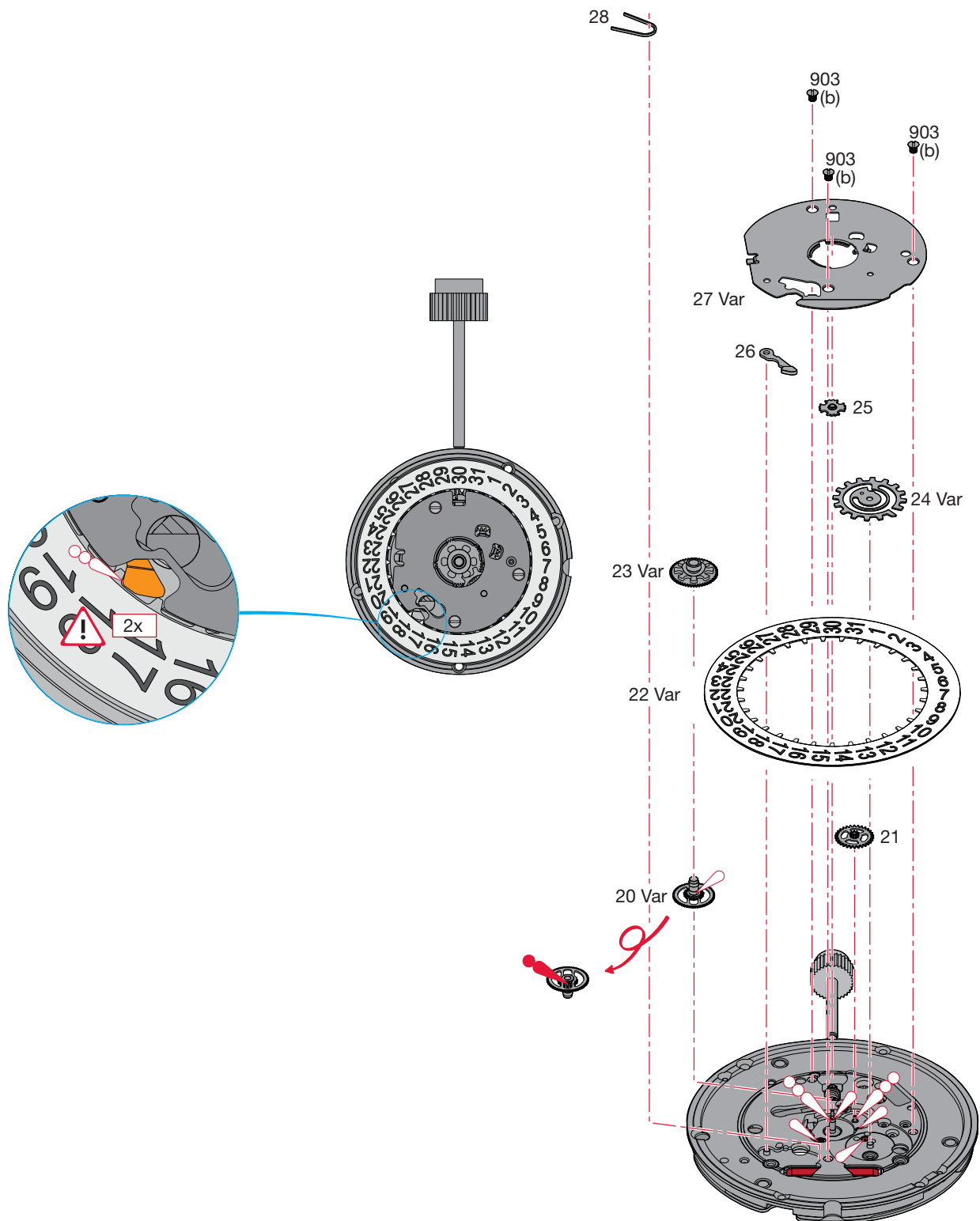

Montage du mécanisme de mise à l'heure et du mécanisme de calendrier

(Liste des fournitures par ordre d'assemblage)

Zusammenstellen des Zeigerwerkmechanismus und des Kalendermechanismus

(Bestandteilliste in Montagereihenfolge)

Assembling of the handsetting mechanism and the calendar mechanism

(Parts listed in order of assembly)

20 Var	24 Var	903 (3x)
21	25	28
22 Var	26	
23 Var	27 Var	

Lubrification - Schmierung - Lubrication

 Huile fine
Dünnflüssiges Öl **Moebius 9014**
Fine oil

 Graisse
Fett **Moebius 9501**
Grease

 Huile épaisse ou graisse **Moebius HP-1300**
Dickflüssiges Öl oder Fett **ou / oder / or**
Thick oil or grease **Moebius D5**

	Lubrifier la pièce 26. 1. Teil 26 schmieren. Lubricate part 26.
	Tourner la pièce 22 d'environ 10 dents avec la correction rapide. 2. Teil 22 mit Schnellkorrektur ca. 10 Zähne drehen. Rotate part 22 approx 10 teeth with rapide correction.
	Lubrifier à nouveau la pièce 26. 3. Teil 26 nochmals schmieren. Lubricate again part 26.
	Tourner à nouveau la pièce 22 d'environ 10 dents avec la correction rapide. Teil 22 nochmals mit Schnellkorrektur ca. 10 Zähne drehen. Rotate part 22 approx 10 teeth with rapide correction again.

M_L Couple minimum pour dévisser

M_L Minimales Drehmoment zum Lösen

M_L Minimum torque for loosening

(b) 0,7 Ncm

Ordre d'assemblage - Montager Reihenfolge - Order of assembly:
Pile et ressort de limitation de pile - Batterie und Begrenzungsfeder für Batterie - Battery and battery limiting spring

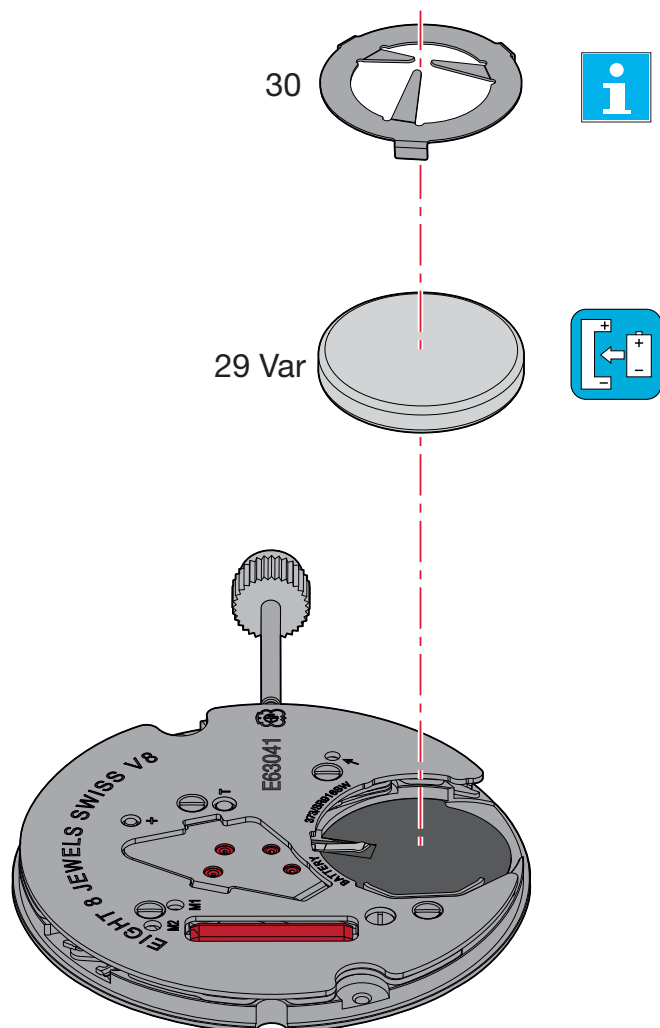

Montage de la pile et du ressort de limitation de pile

(Liste des fournitures par ordre d'assemblage)

Zusammenstellen der Batterie und der Begrenzungsfeder für Batterie

(Bestandteilliste in Montagereihenfolge)

Assembling of the battery and the battery limiting spring

(Parts listed in order of assembly)

29 Var		
30		

Pos 30:

Le ressort de limitation est nécessaire uniquement si la distance entre la pile et le fond de la boîte est trop élevée.

Pour de plus amples informations, voir:

Information Habillage

"CAGE POUR BOITE"



Die Begrenzungsfeder ist nur nötig, wenn der Abstand von der Batterie zum Gehäusoboden zu gross ist.

Für weitere Informationen siehe:

Fabrikanten Information

"UHRWERKGESTELL FÜR GEHÄUSE"

The limit spring is only necessary when the distance from the battery to the base of the casing is too far.

For further details please go to:

Manufacturing Information

"FRAME FOR CASE"

Contrôles électriques - Elektrische Kontrollen - Electrical Tests

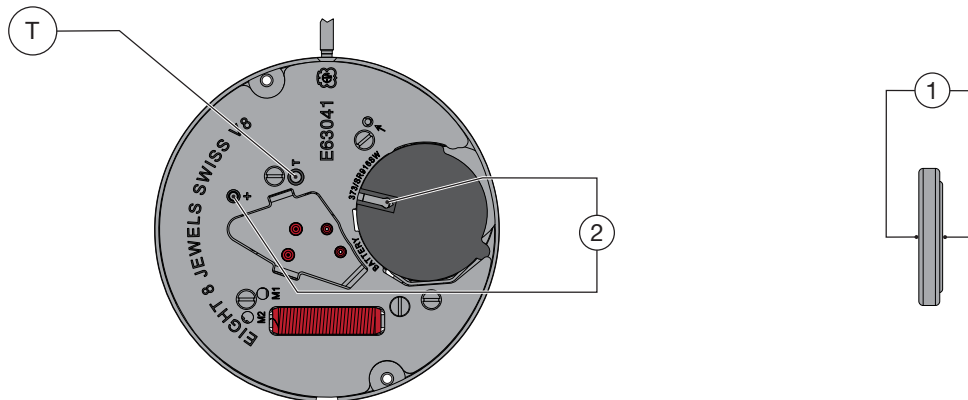

Position Messpunkt Position	Echelle de mesure Einstellung Messgerät Setting of apparatus	Mesure Messung Measurement	Contrôle Kontrolle Test	Remarques Bemerkungen Remarks
1	2 V	1,55 V	Tension de la pile Spannung der Batterie Battery voltage	
2	2 V	Le mouvement est doté du "Watchmodul C7". Das Werk ist mit dem "Watchmodul C7" ausgerüstet. The movement is fitted with a "Watchmodul C7".		
		Commande du moteur avec 30 pas/min.	Limite inférieure de la tension de fonctionnement.	Mesure sans pile, alimentation extérieure variable, en descendant de 1,55 V à l'arrêt du mouvement.
		Motorantrieb mit 30 Schritte/Min.	Untere Funktionsspannungsgrenze.	Messung ohne Batterie mit variabler Speisespannung, Spannung von 1,55 V reduzieren bis zum Stillstand des Werkes.
	Motor driven with 30 steps/min.	Lower working-voltage limit.	Measurement without battery, with variable external power supply, starting with 1.55 V, lower tension until movement stops.	
10 µA	10 µA	≤ 1,0 µA	Consommation du mouvement. Stromaufnahme Uhrwerk. Consumption of movement.	Mesure sans pile, avec alimentation extérieure 1,55 V. Messung ohne Batterie, mit externer Speisung 1,55 V. Measurement without battery, with external power supply 1.55 V.
		≤ 0,5 µA	Fonctionnement de l'interrupteur en pos. 3 de la tige de mise à l'heure. Funktion des Stopphebels, Pos. 3 der Zeigerstellwelle. Function of stop lever, pos. 3 of handsetting stem.	Mesure sans pile, avec alimentation extérieure 1,55 V. Messung ohne Batterie, mit externer Speisung 1,55 V. Measurement without battery, with external power supply 1.55 V.

REMARQUES:

Mode accéléré:

Pour des mesures et des contrôles en mode accéléré, veuillez prendre contact avec le Customer Service de la société ETA SA.

BEMERKUNGEN

Beschleunigter Modus:

Für Messungen und Kontrollen im beschleunigten Modus nehmen Sie bitte mit dem Customer Service der ETA SA Kontakt auf.

REMARKS

Accelerated mode:

For measurements and controls in accelerated mode, please contact ETA SA customer Services.

Contrôle de la marche instantanée

Pour des informations concernant le contrôle de la marche instantanée voir:

Information Habillage:

- Contrôle de la marche

Kontrolle des momentanen Ganges

Für Informationen betreffend der Kontrolle des momentanen Ganges siehe:

Fabrikanten Information:

- Gangkontrolle

Checking the intantaneous rate

For information regarding checking the instantaneous rate see:

Manufacturing information:

- Checking the rate

Identification Precidrive

Kennzeichnung Precidrive

Identification Precidrive

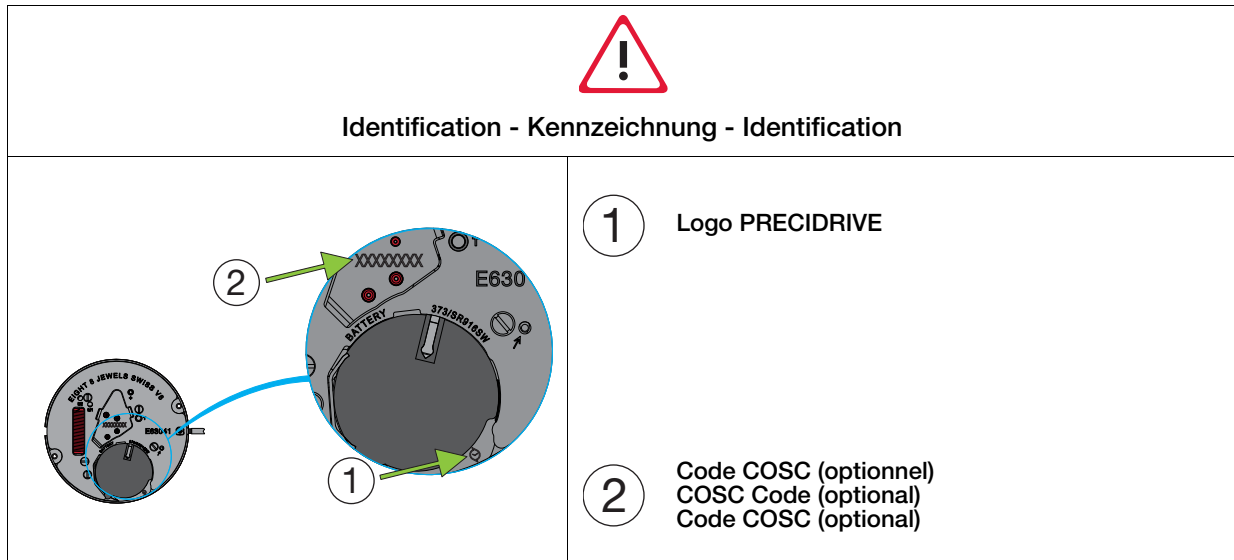

Alimentation

Pile à l'oxyde d'argent
U = 1,55 V, type "Low drain".

Ø 9,50 mm, hauteur 1,65 mm
Capacité 29 mAh (Renata)

Renata 373, Varta V373,
Energizer 373, SR 916 SW.

Ø 9,50 mm, hauteur 2,05 mm
Capacité 40 mAh (Renata)

Renata 371, Varta V371,
Energizer 371, SR 920 SW.

Stromversorgung

Silberoxyd-Batterie
U = 1,55 V, Typ "Low Drain".

Ø 9,50 mm, Höhe 1,65 mm
Kapazität 29 mAh (Renata)

Renata 373, Varta V373,
Energizer 373, SR 916 SW.

Ø 9,50 mm, Höhe 2,05 mm
Kapazität 40 mAh (Renata)

Renata 371, Varta V371,
Energizer 371, SR 920 SW.

Current supply

Silver oxide battery
U = 1.55 V, "Low Drain" type.

Ø 9.50 mm, height 1.65 mm
Capacity 29 mAh (Renata)

Renata 373, Varta V373,
Energizer 373, SR 916 SW.

Ø 9.50 mm, height 2.05 mm
Capacity 40 mAh (Renata)

Renata 371, Varta V371,
Energizer 371, SR 920 SW.

Pose de la pile

Glisser la pile contre la bride de contact ①. Presser la pile au fond de son logement ②. La bride + maintient la pile en place.

La pincette ne doit pas être conductrice d'électricité!

Batterie einsetzen

Die Batterie gegen den Batteriehaltebügel ① einlegen. Danach die Batterie in das Batteriefach drücken ②. Der Finger des Bügels + fixiert die Batterie in der Halterung.

Die Pinzette darf nicht elektrisch leitend sein!

Fitting the battery

Slide the battery against the contact strip ①. Press the battery firmly into its mounting ②. The bridle + keeps the battery in position.

The tweezers must not be electrically conductive!

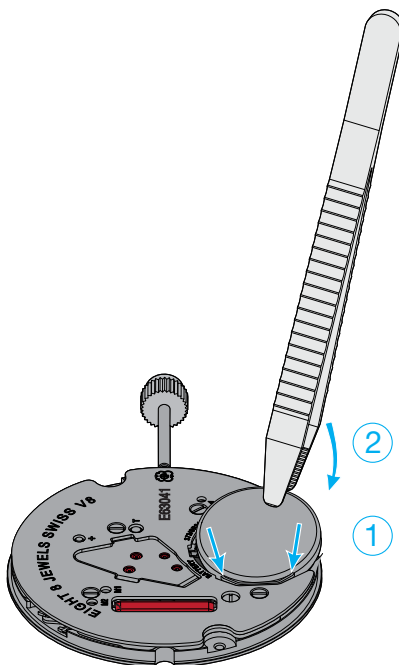

Retrait de la pile

Glisser une brucelle ① entre la platine et la pile (voir dessin) et faire levier sous celle-ci en écartant très légèrement la bride + vers le haut ②. Sortir la pile ③.

La pincette ne doit pas être conductrice d'électricité!

Batterie herausnehmen

Führen Sie eine Pinzette ① zwischen Werkplatte und Batterie ein (siehe Abbildung). Heben Sie die Batterie mit leichtem Druck nach oben ②. Nehmen Sie die Batterie ③ heraus.

Die Pinzette darf nicht elektrisch leitend sein!

Removing the battery

Insert tweezers ① between main plate and battery (see drawing) and lift out the battery by gently lifting back ②. Remove the battery ③.

The tweezers must not be electrically conductive!

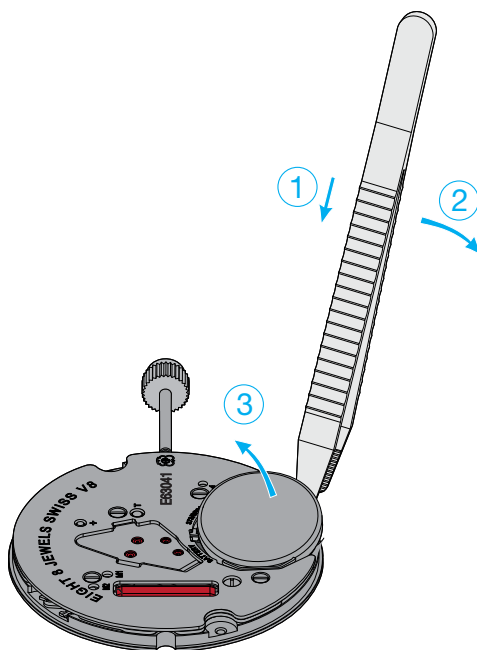

Extraction de la tige de mise à l'heure

Repousser obligatoirement la tige de mise à l'heure en position 1 (neutre) avant de presser sur le point à droite de la tirette.

Entfernen der Stellwelle

Erst die Stellwelle in Position 1 (neutral) drücken, dann zum Lösen der Stellwelle auf den Punkt rechts auf dem Winkelhebel drücken.

Extracting the stem

The handsetting stem must be pushed back to position 1 (neutral) before pressing on the point lying on the right sider of the setting lever.

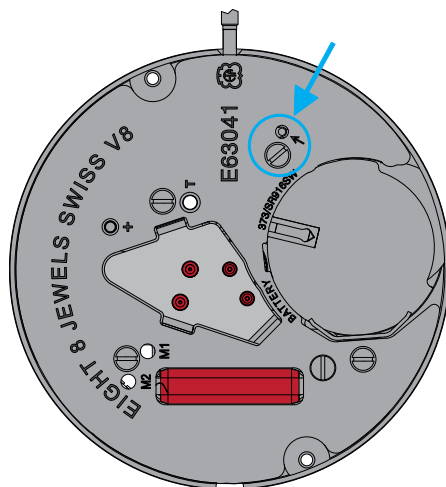



Pour des informations concernant les aiguillages voir:

Information Habillage

Plan:
AIGUILLAGES
ZEIGERWERKHÖHEN
HAND FITTING HEIGHTS



Für Informationen betreffend der Zeigerwerkhöhen siehe:

Fabrikanten Information

Zeichnung:
AIGUILLAGES
ZEIGERWERKHÖHEN
HAND FITTING HEIGHTS



For information regarding hand fitting heights see:

Manufacturing Information

Drawing:
AIGUILLAGES
ZEIGERWERKHÖHEN
HAND FITTING HEIGHTS

Cette page est laissée vide
intentionnellement en cas d'impression
au format A3.

Diese Seite wird absichtlich leer
gelassen für den Fall, dass im
A3-Format gedruckt wird.

This page has deliberately been
left blank in case of A3 format
printing.

Cette page est laissée vide
intentionnellement en cas d'impression
au format A3.

Diese Seite wird absichtlich leer
gelassen für den Fall, dass im
A3-Format gedruckt wird.

This page has deliberately been
left blank in case of A3 format
printing.

Cette page est laissée vide
intentionnellement en cas d'impression
au format A3.

Diese Seite wird absichtlich leer
gelassen für den Fall, dass im
A3-Format gedruckt wird.

This page has deliberately been
left blank in case of A3 format
printing.

**Modifications comparées aux versions
précédentes du document****Änderungen gegenüber vorher-
gehenden Dokumentversionen****Modifications compared with previous
document versions**

Version	Date Datum Date	Modification	Änderung	Modification	Page Seite Page
03	22.06.2015	Ajout symbole Precidrive	Ergänzung Symbol Precidrive	Addition symbole Precidrive	1, 17
02	11.08.2014	Nouveau plan	Neue Zeichnung	New drawing	19
01	12.04.2013	Nouveau plan	Neue Zeichnung	New drawing	19
00	18.06.2012	Version de base	Basis Version	Basic version	--

Sous réserve de toutes modifications.

Änderungen vorbehalten.

All modifications reserved.

**Ce document se trouve sur le
Support Center Portal (SCP) :****www.eta.ch**

- Support Center
- Support Center Portal
- Documents techniques

**Dieses Dokument finden Sie im
Support Center Portal (SCP):****www.eta.ch**

- Support Center
- Support Center Portal
- Technische Dokumente

**This document can be found on the
Support Center Portal (SCP):****www.eta.ch**

- Support Center
- Support Center Portal
- Technical Documents

**ETA**^{SA}MANUFACTURE HORLOGÈRE SUISSE
DEP. N. 5.1793

SC PRODUCT COMMUNICATION

Bahnhofstrasse 9
2540 Grenchen
SwitzerlandPhone +41 (0)32 655 71 11
Fax +41 (0)32 655 71 74contact@eta.ch
www.eta.ch



10 1/2" ETA E63.041

CT E63041 ESI 535323 03 22.06.2015



10 1/2" Ø 23,30 mm

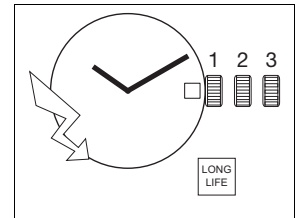

Movement height	Altura sobre máquina	Altezza sopra movimento	1,95 mm
Height on battery	Altura sobre pila	Altezza sopra pila	No 373: 2,10 mm No 371: 2,50 mm
Number of jewels	Número de piedras	Numero di pietre	8
Frequency	Frecuencia	Frequenza	32'768 Hz

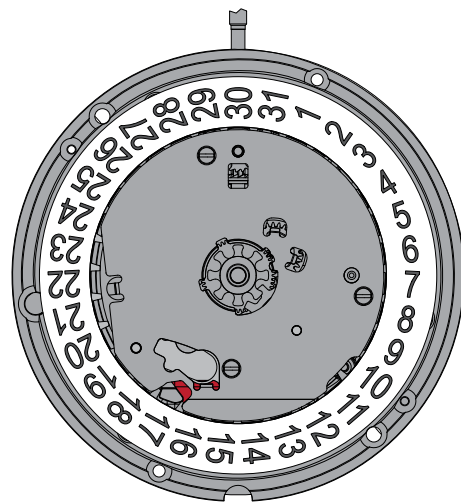
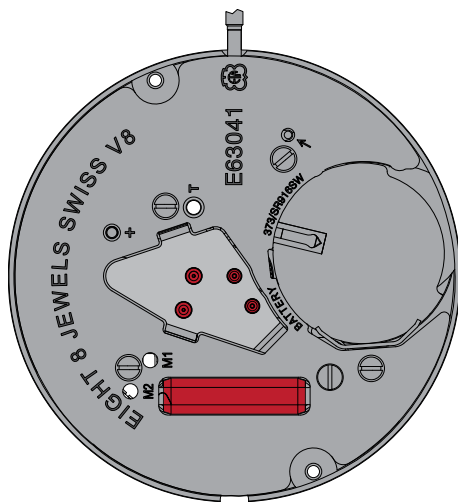

The repair and reconditioning work must only be performed by properly trained personnel.
Las tareas de reparación y revisión sólo deben ser llevadas a cabo por personal debidamente formado.
I lavori di riparazione e di revisione devono essere eseguiti esclusivamente da personale adeguatamente formato.



General information



Before starting work, please study this "Technical communication" carefully.



Eye protection is obligatory for all operations / work on the movement!



ETA SA disclaims any liability in case of damage arising from failure to observe this "Technical communication".

Environmental protection requirements



The legal provisions relating to waste handling and disposal must be observed in all operations / work on the movement!

In particular, lubricating and cleaning products harmful to the environment must be disposed of in accordance with the rules!



Substances prone to cause water pollution must be stored, transported, collected and disposed of in appropriate vessels.

Under no circumstances must they pollute the soil or be poured into sewage systems!

Explanation of symbols



Caution! Risk of material damage!

Below are some obligatory instructions for preventing any material damage!



Below is some advice for use and important information.

Información general



Esta "Comunicación técnica" deberá estudiarse muy bien **antes** de comenzar los trabajos.



Es obligatorio utilizar protección ocular para todos los trabajos en y con el reloj.



ETA SA no se hace responsable de los daños provocados como consecuencia de la inobservancia de esta "Comunicación técnica".

Normas de protección medioambiental



Deberá cumplirse la normativa legal relativa al reciclaje y la eliminación correctos de los residuos en todos los trabajos en y con el reloj.

En especial, deberán eliminarse correctamente los productos lubricantes y de limpieza peligrosos para el medio ambiente.



Las sustancias contaminantes del agua deben recogerse, almacenarse, transportarse y eliminarse en recipientes adecuados.

En ningún caso se permitirá que contaminen el suelo o que lleguen a la canalización.

Significado de los símbolos



Atención Peligro de daños materiales

Instrucciones que deberán respetarse necesariamente para evitar daños materiales.



Consejos de aplicación e información importantes.

Informazioni generali



Questa "Comunicazione Tecnica" deve essere studiata attentamente **prima** dell'inizio dei lavori.



Per tutti i lavori su e con il movimento dell'orologio è obbligatorio proteggere gli occhi!



ETA SA declina qualunque responsabilità per eventuali danni causati dalla mancata osservanza della presente "Comunicazione tecnica".

Disposizioni relative alla protezione ambientale



Per tutti i lavori su e con il movimento dell'orologio si dovranno rispettare le disposizioni di legge relative al corretto riciclaggio e smaltimento dei rifiuti!

In particolare si dovrà provvedere al corretto smaltimento di lubrificanti e detergenti nocivi per l'ambiente!



Le sostanze inquinanti per l'acqua devono essere conservate, trasportate, raccolte e smaltite in contenitori adatti.

Queste non devono inquinare il terreno o arrivare nelle canalizzazioni!

Spiegazione dei simboli



Attenzione! Pericolo di danni materiali!

Seguono importanti indicazioni che devono essere tassativamente rispettate per evitare danni materiali!



Seguono consigli per l'uso e informazioni importanti.

List of components - Lista de piezas - Lista fornitori

Pos	Article number Número de artículo Numero articolo	List of components	Lista de piezas	Lista fornitori
1	Var	Main plate, assembled	Platina, montada	Piastra, montata
2	7613226088788	Sliding pinion	Piñón corredizo	Pignone scorrevole
3	7613226088474	Handsetting stem	Tija de puesta en hora	Albero di messa all'ora
4	7613226088795	Yoke	Báscula de piñón corredizo	Bascula del pignone scorrevole
5	7613226088801	Setting lever, assembled	Tirete, montado	Tiretto, montato
6	7613226088818	Setting lever jumper	Muelle flexible de tirete	Scatto del tiretto
7	7613226088832	Time setting gear	Rueda de transmisión de puesta en hora	Rinvio di messa all'ora
8	7613226088849	Distance piece for bridle -	Tirante de brida -	Spessore della brida -
9	7613226088856	Stator	Estátor	Statore
10	7613226088863	Rotor	Rotor	Rotore
11	7613226118119	Intermediate wheel	Rueda intermedia	Ruota intermedia
12	7613226088887	Third wheel	Rueda primera	Ruota mediana
13	7613226118102	Second wheel without seconde	Rueda de segundos sin segundo	Ruota dei secondi senza secondi
14	Var	Train wheel bridge, jewelled	Puente de rodaje, empedrado	Ponte del ruotismo, con pietre
15	7613226088467	Bobine, montée	Spule, montiert	Coil, assembled
16	7613226088931	Bridle +	Brida +	Brida +
17	7613226088948	Battery insulator	Aislador de pila	Isolatore della pila
18	Var	Electronic module	Módulo electrónico	Modulo elettronico
19	7613226139237	Electronic module cover	Cubre-módulo electrónico	Copri-modulo elettronico
20	Var	Cannon pinion with driving wheel	Cañón de minutos con arrastrador	Pignone calzante con conduttore
21	7613226086418	Minute wheel, assembled	Rueda de minutería, montada	Ruota della minutería, montata
22	Var	Date indicator	Indicador de fecha	Indicatore della data
23	Var	Hour wheel, assembled	Rueda de horas, montada	Ruota delle ore, montata
24	Var	Date indicator driving wheel	Rueda de arrastre del indicador de fecha	Ruota conduttrice ell'indicatore della data
25	7613226086449	Date corrector	Corrector de fecha	Correttore della data
26	7613226086456	Date jumper	Muelle flexible de fecha	Scatta-data
27	Var	Calendar mechanism maintaining plate	Placa de sujeción del mecanismo de calendario	Placca di guardia del meccanismo del calendario
28	7613226086463	Date jumper spring	Resorte del muelle flexible de fecha	Molla dello scatta-data
29	Var	Battery	Pila	Pila
30	7613226018242	Battery limiting spring	Muelle de limitación de pila	Molla di limitazione della pila
900	7613226086524	Cylindrical head screw - Pos. 8: Screw for distance piece for bridle- 1x - Pos. 14: Screw for train wheel bridge 1x - Pos. 16: Screw for bridle + 1x	Tornillo de cabeza cilíndrica - Pos. 8: Tornillo de tirante de brida - - Pos. 14: Tornillo del puente de rodaje - Pos. 16: Tornillo de brida +	Vite a testa cilíndrica - Pos. 8: Vite del spessore della brida - - Pos. 14: Vite per ponte del ruotismo - Pos. 16: Vite per brida +
901	7613226086531	Countersunk head screw - Pos. 19: Screw for electronic module cover 3x	Tornillo de cabeza cónica - Pos. 19: Tornillo del cubre-módulo electrónico	Vite a testa conica - Pos. 19: Vite del copri-módulo elettronico
902	7613226086548	Shouldered flat head screw - Pos. 19: Screw for electronic module cover 1x	Tornillo de asiento, cabeza chata - Pos. 19: Tornillo del cubre-módulo electrónico	Vite con piano di appoggio, testa piana - Pos. 19: Vite del copri-módulo elettronico
903	7613226086555	Countersunk head screw - Pos. 27: Screw for calendar mechanism maintaining plate 3x	Tornillo de cabeza cónica - Pos. 27: Tornillo de placa de sujeción del mecanismo de calendario	Vite a testa conica - Pos. 27: Vite placca di guardia del meccanismo del calendario
-				
		Variant	Variante	Variante

**Interchangeability and variants
can be found on the
ETA ONLINE SHOP (EOS):**

www.eta.ch

- Support Center
- Support Center Portal

**La intercambiabilidad y las
variantes se encuentran en
ETA ONLINE SHOP (EOS):**

www.eta.ch

- Support Center
- Support Center Portal

**L'intercambiabilità e le varianti si
trovano sul
ETA ONLINE SHOP (EOS):**

www.eta.ch

- Support Center
- Support Center Portal

Materials - Fornituras - Forniture

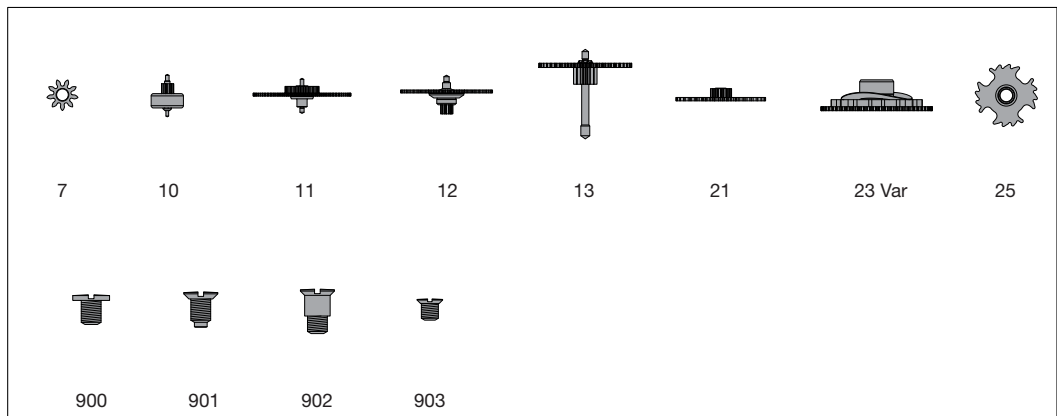
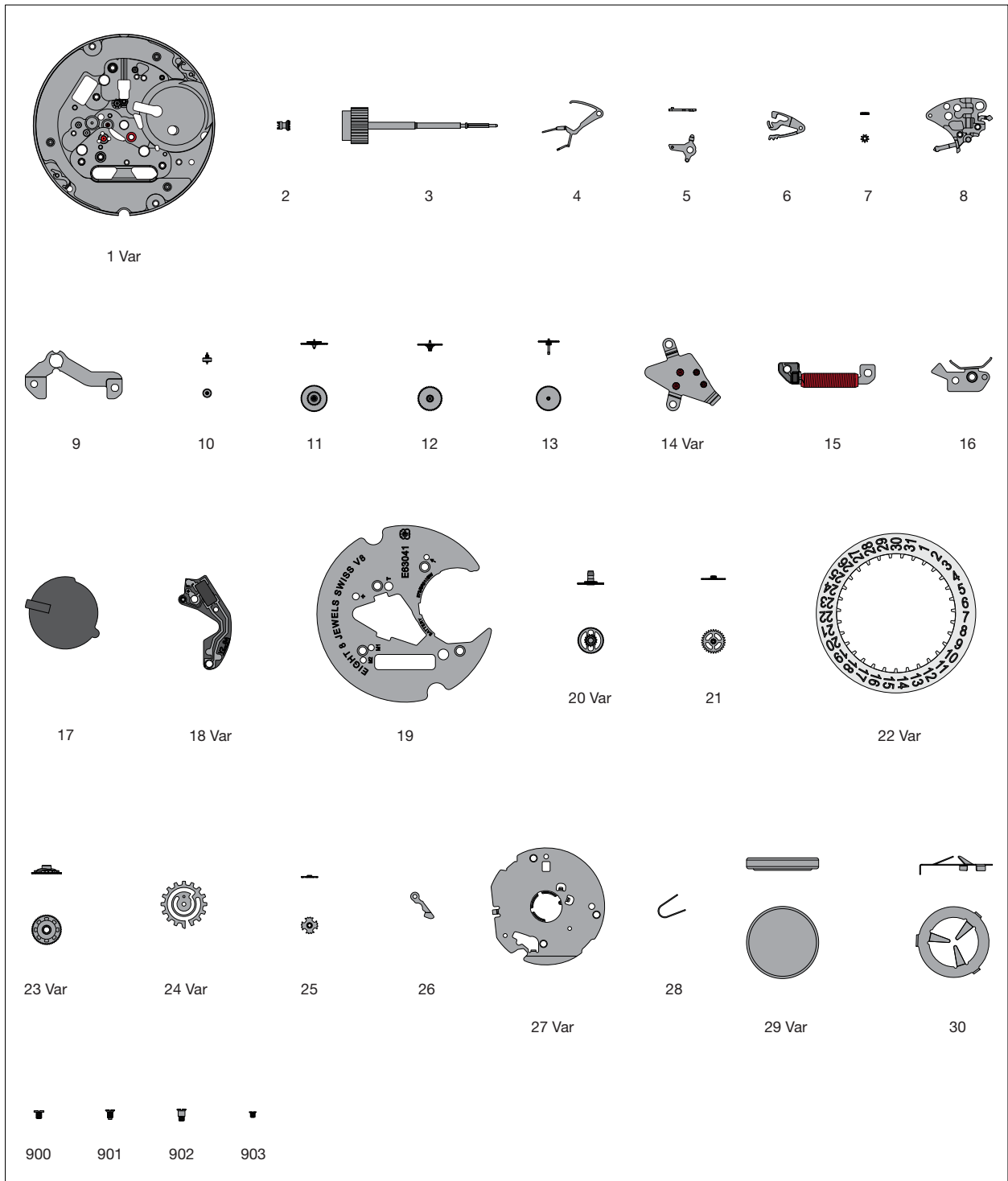

Order of assembly - Orden del montaje - Ordine dell'assemblaggio:
 Basic movement - Máquina de base - Movimento di base

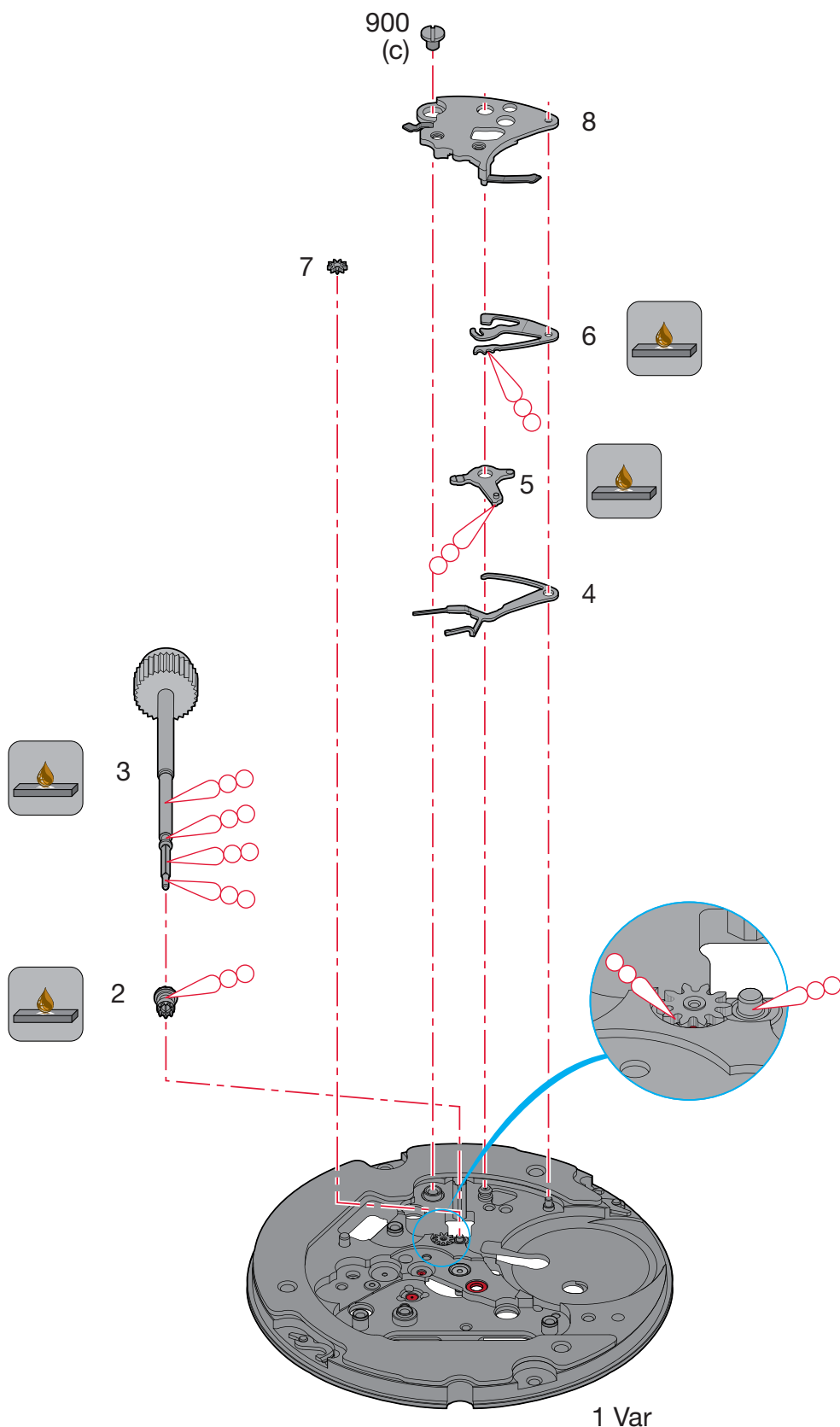

Assembling of the basic movement

(Parts listed in order of assembly)

Montaje de la máquina de base

(Lista de fornitureas por orden de ensamblado)

Montaggio del movimento di base

(Elenco delle forniture in ordine di montaggio)

1 Var	5	900 (1x)
2	6	
3	7	
4	8	

Lubrication - Lubricación - Lubrificazione



Thick oil or grease
Aceite espeso o grasa
Olio denso o grasso

**Moebius
HP-1300**
or / ó / o
Moebius D5



If the pieces to be assembled are not new, existing components must be treated with Moebius Fixodrop FK/BS 8941 before reassembly.

Si las piezas por ensamblar no son nuevas, los componentes existentes deben ser tratados con el Moebius Fixodrop FK/BS 8941.

Se non vengono montati dei nuovi pezzi, i componenti esistenti devono essere trattati prima del rimontaggio con Moebius Fixodrop FK/BS 8941.

Moebius Fixodrop FK/BS 8941



Volatile
Flüchtig
Volatile

Very volatile product!

Keep in closed and airtight containers after usage.

Producto muy volátil!

Para su uso posterior, mantener cerrados en recipientes herméticos.

Prodotto molto volatile!

Da conservare dopo l'uso in recipienti ermeticamente chiusi.

M_L Minimum torque for loosening

M_L Par mínimo para desatornillar

M_L Coppia minima per svitare

(c) 0,8 Ncm

Order of assembly - Orden del montaje - Ordine dell'assemblaggio:
Wheel train - Rodaje - Ruotismo

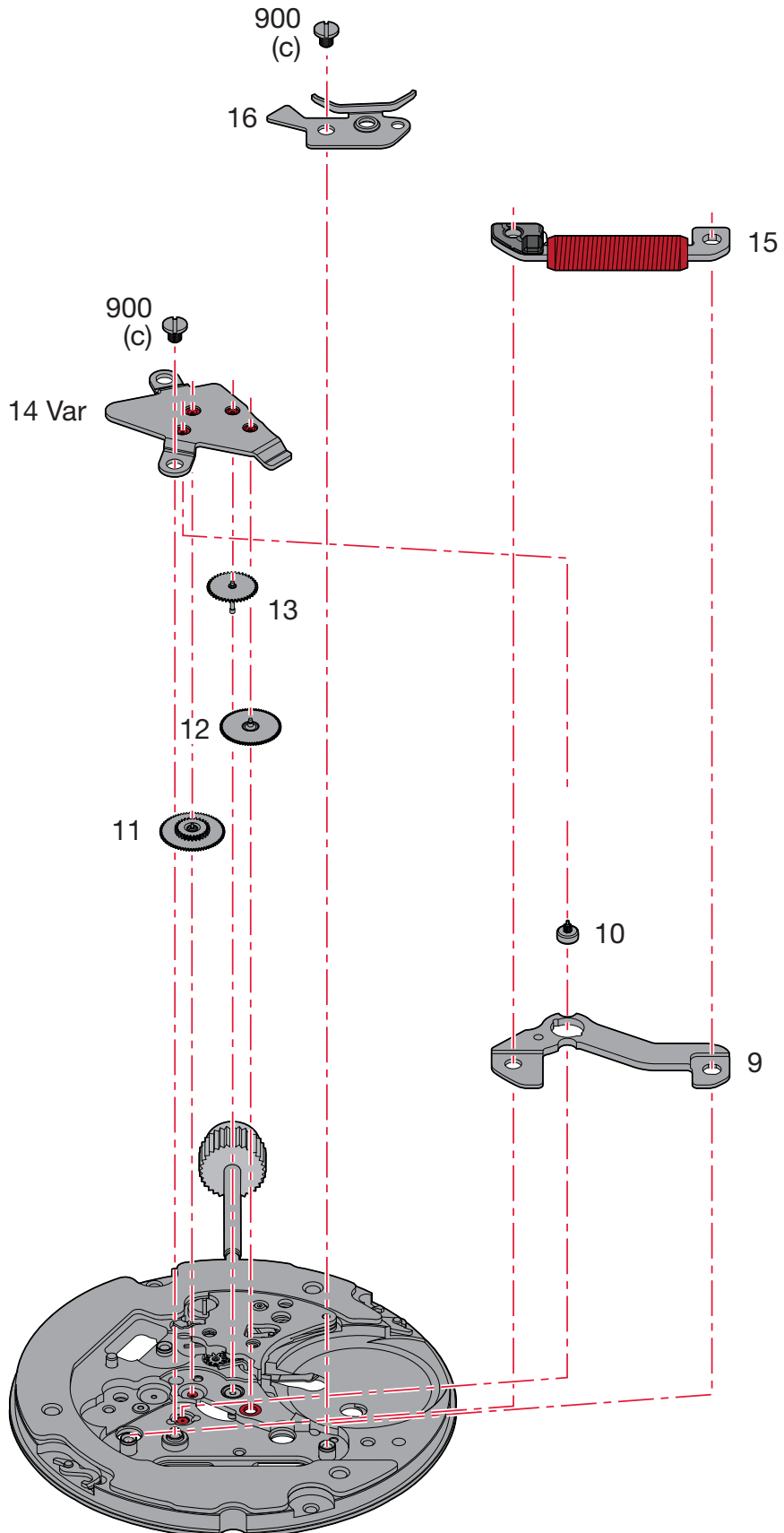

Assembling of the wheel train

(Parts listed in order of assembly)

Montaje del rodaje

(Lista de fornitureas por orden de ensamblado)

Montaggio del ruotismo

(Elenco delle forniture in ordine di montaggio)

9	13	16
10	14 Var	900 (1x)
11	900 (1x)	
12	15	

M_L Minimum torque for loosening**M_L Par mínimo para desatornillar****M_L Coppia minima per svitare**

(c) 0,8 Ncm

Order of assembly - Orden del montaje - Ordine dell'assemblaggio:
Electronic module - Módulo electrónico - Modulo elettronico

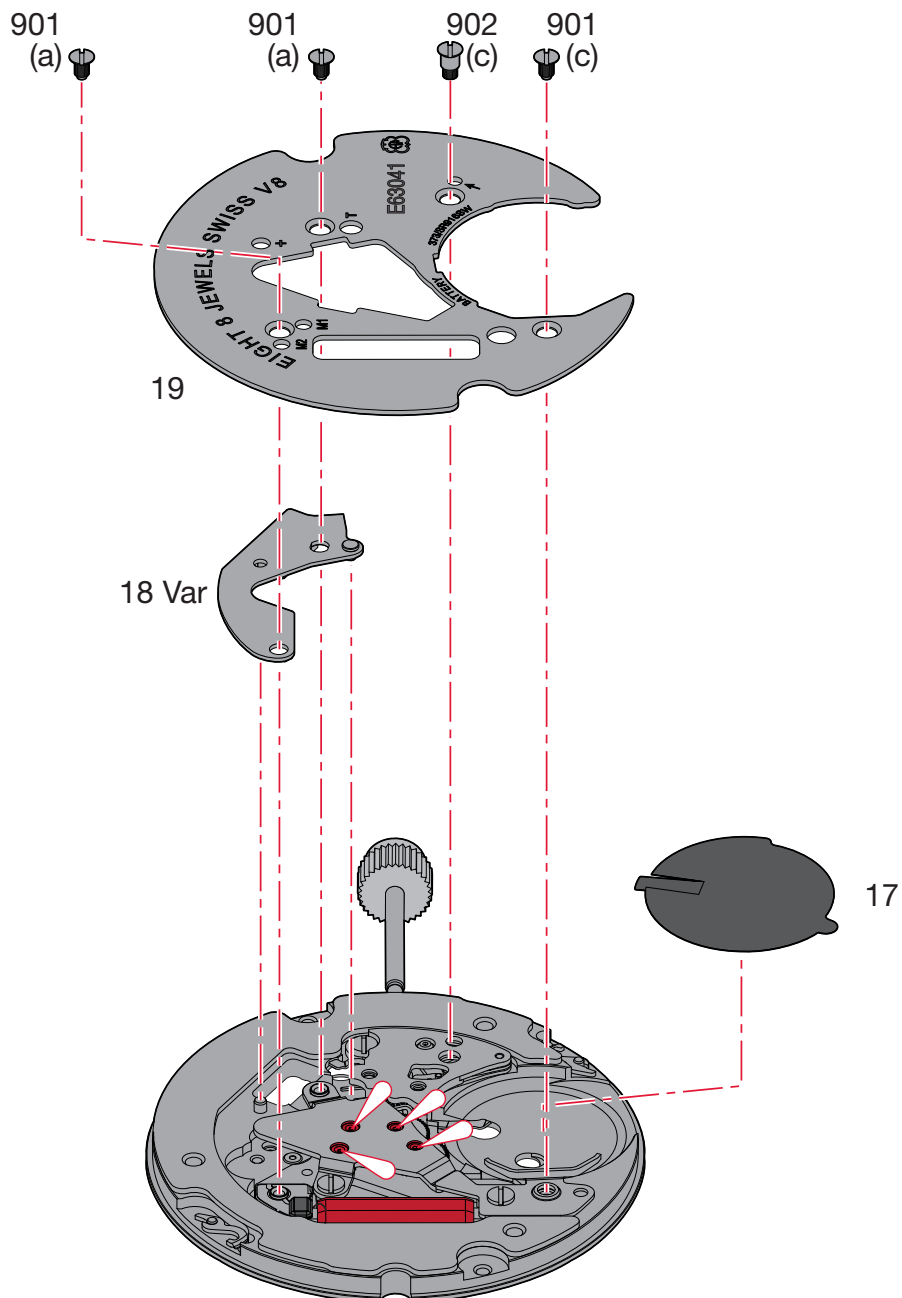

Assembling of the electronic module

(Parts listed in order of assembly)

Montaje del módulo electrónico

(Lista de fornitureas por orden de ensamblado)

Montaggio del modulo elettronico

(Elenco delle forniture in ordine di montaggio)

17	901 (3x)	
18 Var	902 (1x)	
19		

Lubrication - Lubricación - Lubrificazione

 Fine oil
Aceite fino **Moebius 9014**
Olio fluido

M_L Minimum torque for loosening**M_L Par mínimo para desatornillar****M_L Coppia minima per svitare**

- (a) 0,5 Ncm
- (c) 0,8 Ncm

Order of assembly - Orden del montaje - Ordine dell'assemblaggio:
 Handsetting mechanism and the calendar mechanism - Mecanismo de puesta en hora y de calendario -
 Meccanismo della messa all'ora e del calendario

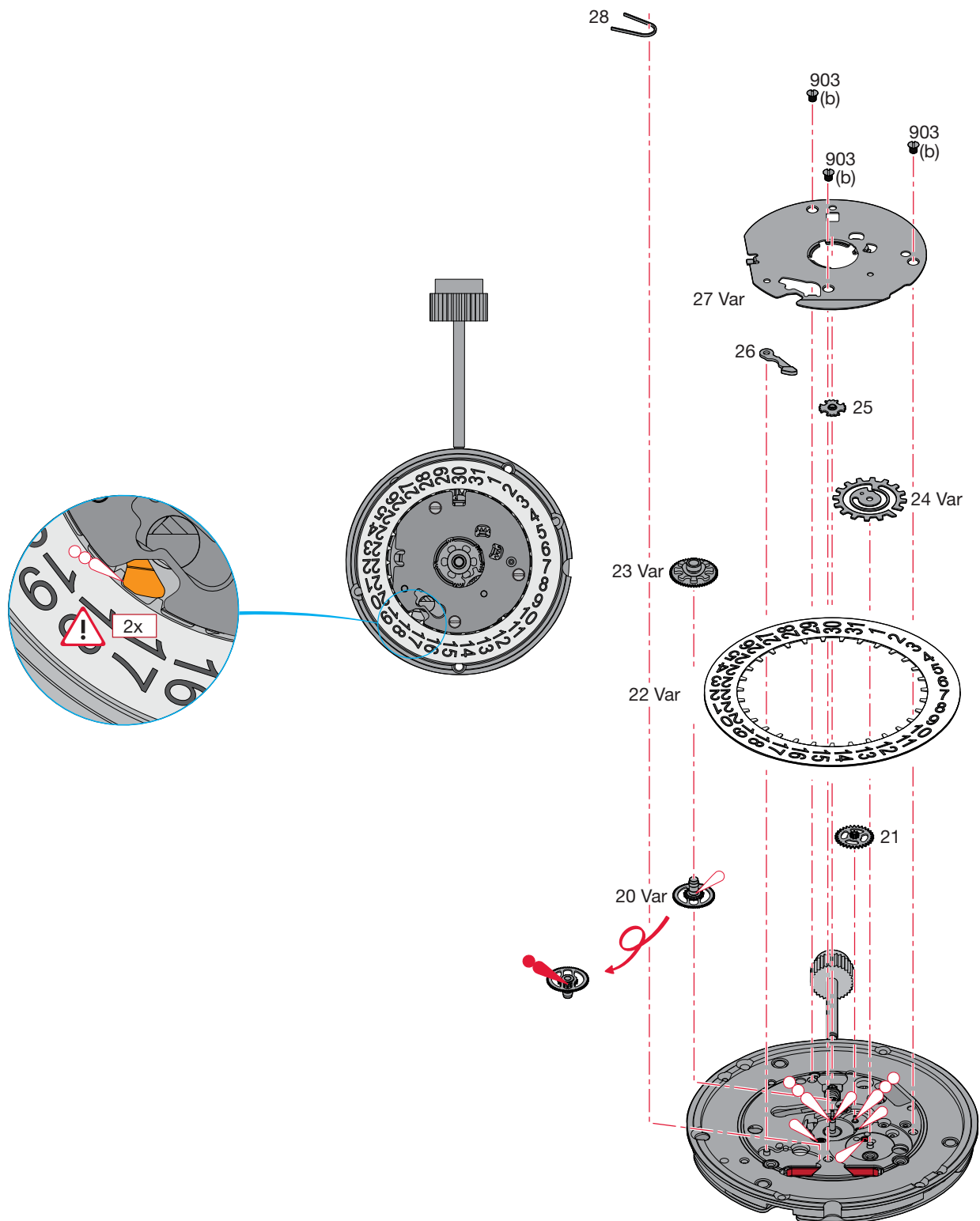

Assembling of the handsetting and the calendar mechanism

(Parts listed in order of assembly)

Montaje del mecanismo de puesta en hora y del mecanismo de calendario

(Lista de fornitureas por orden de ensamblado)

Montaggio della messa all'ora e del meccanismo del calendario

(Elenco delle forniture in ordine di montaggio)

20 Var	24 Var	903 (3x)
21	25	28
22 Var	26	
23 Var	27 Var	

Lubrication - Lubricación - Lubrificazione

 Fine oil
Aceite fino **Moebius 9014**
Olio fluido

 Grease
Grasa **Moebius 9501**
Grasso

 Thick oil or grease
Aceite espeso o grasa **Moebius HP-1300**
Olio denso o grasso **or / ó / o Moebius D5**

	Lubricate part 26. 1. Lubrique la pieza 26. Lubrificare il pezzo 26.
	Rotate part 22 approx 10 teeth with rapide correction. 2. Gire la pieza 22 unos 10 dientes con la corrección rápida. Ruotare il pezzo 22 di circa 10 denti con la correzione rapida.
	Lubricate again part 26. 3. Lubrique de nuevo la pieza 26. Lubrificare di nuovo il pezzo 26.
	Rotate part 22 approx 10 teeth with rapide correction again. 4. Gire de nuevo la pieza 22 unos 10 dientes con la corrección rápida. Ruotare di nuovo il pezzo 22 di circa 10 denti con la correzione rapida.

M_L Minimum torque for loosening**M_L Par mínimo para desatornillar****M_L Coppia minima per svitare**

(b) 0,7 Ncm

Order of assembly - Orden del montaje - Ordine dell'assemblaggio:
Battery and battery limiting spring - Pila para el muelle limitación de pila - Pila per la molla di limitazione della pila

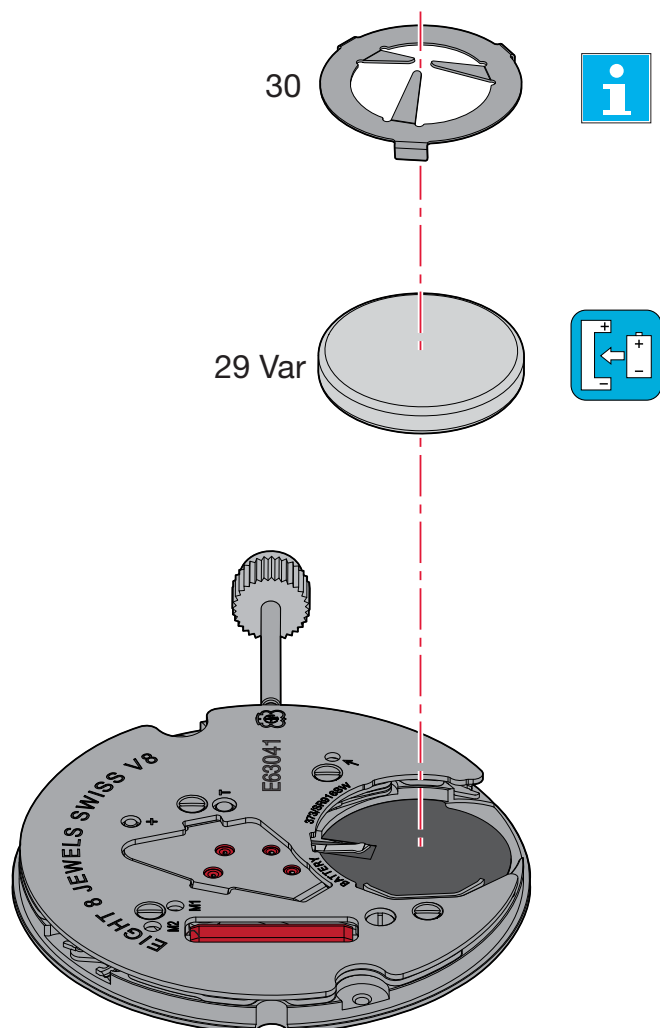

Assembling of the battery and the battery limiting spring

(Parts listed in order of assembly)

Montaje de la pila para el muelle de limitación de pila

(Lista de forniture por orden de ensamblado)

Montaggio pila per la molla di limitazione della pila

(Elenco delle forniture in ordine di montaggio)

29 Var

30

Pos 30:

The limit spring is only necessary when the distance from the battery to the base of the casing is too far.

For further details please go to:

Manufacturing Information

"FRAME FOR CASE"



El muelle de sujeción solo es necesario si la distancia entre la pila y el fondo de la caja es demasiado grande.

Para más información, véase:

Información del fabricante

"ARMAZÓN DE LA CAJA"

La molla distanziatrice è necessaria solo in caso di distanza ampia tra la batteria e il fondo della cassa.

Per dettagli, vedere:

Informazioni del produttore

"STRUTTURA PER CASSA"

Electrical tests - Controles eléctricos - Controlli elettrici

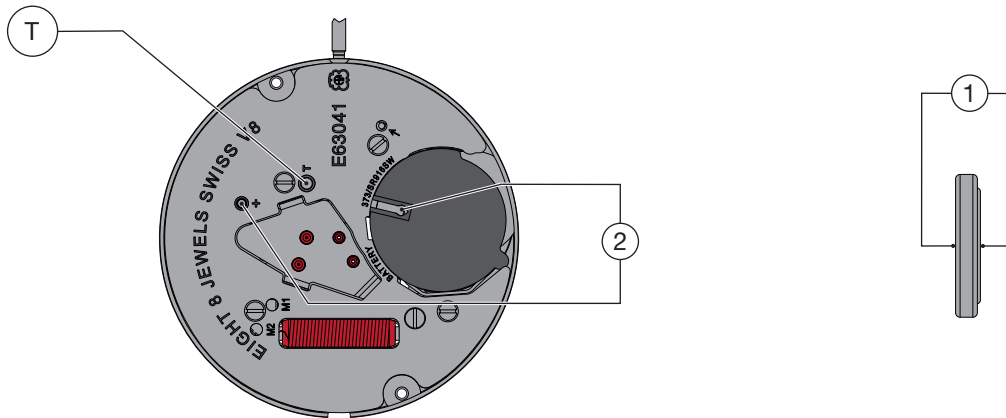

Position Posición Posizione	Setting of apparatus Escala de medición Scala di misura	Measurement Medición Misura	Test Control Controllo	Remarks Notas Osservazioni
1	2 V	1,55 V	Battery voltage Tensión de la pila Tensione de la pila	
2	2 V	The movement is fitted with a "Watchmodul C7". El movimiento está equipado con el módulo de reloj C7. Il meccanismo è dotato del modulo orologio C7.		
		Motor driven with 30 steps/min. Mando del con 30 pasos/min. Comando del motore con 30 passi/min.	Lower working-voltage limit. Limite inferior de la tensión de funcionamiento. Limite inferiore della tensione di funzionamento.	Measurement without battery, with variable external power supply, starting with 1.55 V, lower tension until movement stops. Medición sin pila, con alimentación exterior variable bajando de 1,55 V hasta la parada de la máquina. Misura senza pila con alimentazione esterna variabile, scendendo da 1,55 V fino all'arresto del movimento.
	10 µA	Consumption of movement Consumo de la máquina Consumo del movimento.	Consumption of movement Consumo de la máquina Consumo del movimento.	Measurement without battery, with external power supply 1.55 V. Medición sin pila, con alimentación exterior de 1,55 V. Misura senza pila con alimentazione esterna di 1,55 V.
		Function of stop lever, pos. 3 of handsetting stem. Funcionamiento del interruptor en pos. 3 de la tija de puesta en hora. Funzionamento dell'interruttore in posizione 3 dell'albero di messa all'ora.	Function of stop lever, pos. 3 of handsetting stem. Funcionamiento del interruptor en pos. 3 de la tija de puesta en hora. Funzionamento dell'interruttore in posizione 3 dell'albero di messa all'ora.	Measurement without battery, with external power supply 1.55 V. Medición sin pila, con alimentación exterior de 1,55 V. Misura senza pila con alimentazione esterna di 1,55 V.

REMARQUES:

Accelerated mode:

For measurements and controls in accelerated mode, please contact ETA SA customer Services.

BEMERKUNGEN

Modo acelerado:

Para mediciones y controles en modo acelerado, póngase en contacto con el servicio de atención al cliente de ETA SA.

REMARKS

Modalità accelerata:

Per misurazioni e controlli in modalità accelerata, vi invitiamo a contattare il servizio clienti di ETA SA.

Checking the instantaneous rate

For information regarding checking the instantaneous rate see:

Manufacturing Information:

- Checking the rate

Control de la marcha instantánea

Para información sobre el control de la marcha instantánea véase:

Información productor:

- Control de la march

Controllo della marcia istantánea

Per informazioni riguardo il controllo della marcia istantanea vedere:

Informazioni produttori:

- Controllo della marcia

Identification Precidrive

Identificación Precidrive

Identificazione Precidrive

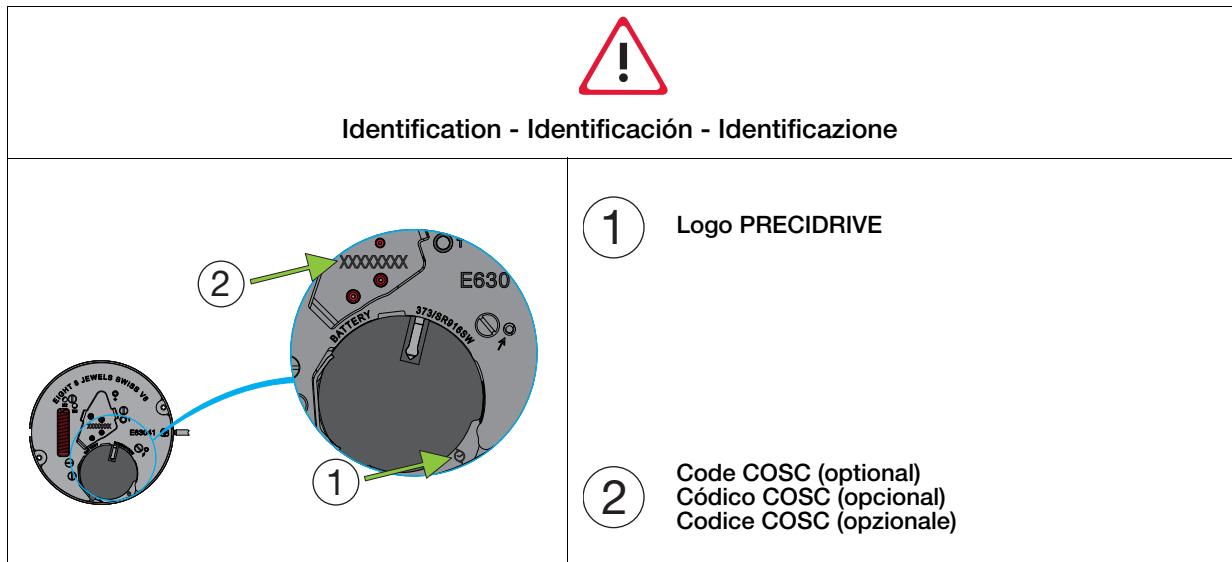

Current supply

Silver oxide battery
U = 1.55 V, "Low Drain" type.

Ø 9.50 mm, height 1.65 mm
Capacity 29 mAh (Renata).

Renata 373, Varta V373,
Energizer 373, SR 916 SW.

Ø 9.50 mm, height 2.05 mm
Capacity 40 mAh (Renata).

Renata 371, Varta V371,
Energizer 371, SR 920 SW.

Alimentación

Pila al óxido de plata.
U = 1,55 V, tipo "Low Drain".

Ø 9,50 mm, Höhe 1,65 mm
Capacidad 29 mAh (Renata).

Renata 373, Varta V373,
Energizer 373, SR 916 SW.

Ø 9,50 mm, Höhe 2,05 mm
Capacidad 40 mAh (Renata).

Renata 371, Varta V371,
Energizer 371, SR 920 SW.

Alimentazione

Pila all'ossido d'argento
U = 1,55 V, tipo "Low Drain" type.

Ø 9,50 mm, height 1,65 mm
Capacità 29 mAh (Renata).

Renata 373, Varta V373,
Energizer 373, SR 916 SW.

Ø 9,50 mm, height 2,05 mm
Capacità 40 mAh (Renata).

Renata 371, Varta V371,
Energizer 371, SR 920 SW.

Fitting the battery

Slide the battery against the contact strip
①. Press the battery firmly into its
mounting ②. The contact strip keeps the
battery in position.

*The tweezers must not be electrically con-
ductive!*

Colocación de la pila

Colocar la pila debajo de las dos lengüetas
metálicas del cubre-módulo ①. Apretar la
pila al fondo de su alojamiento ②. El dedo
del cubre-módulo sujeta la pila en
su sitio.

*Las pinzas no deben ser conductoras de la
electricidad!*

Posa della pila

Far scivolare la pila sotto le due linguette
metalliche del copri-modulo ①. Premere
la pila al fondo del suo alloggio ②. Il dito
del copri-modulo mantiene la pila nella sua
posizione.

La pinzetta non deve condurre elettricità!

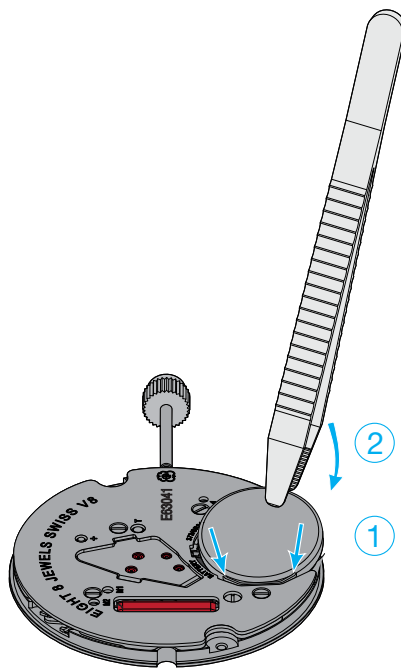

Removing the battery

Insert tweezers ① between module and
battery (see drawing) and pry out the bat-
tery by gently lifting back ② the contact
strip. Remove the battery ③.

*The tweezers must not be electrically con-
ductive!*

Retiro de la pila

Insertar unas pinzas ① entre el módulo y
la pila (véase dibujo) y palanquear la pila
apartando cuidadosamente el dedo del
cubre-módulo ②. Sacar la pila ③.

*Las pinzas no deben ser conductoras de la
electricidad!*

Ritiro della pila

Far scivolare una pinzetta ① tra il modulo
e la pila (vedi disegno) e fare leva sotto
quest'ultima allargando leggermente il dito
di sostegno verso dietro ②.
Ritirare la pila ③.

La pinzetta non deve condurre elettricità!

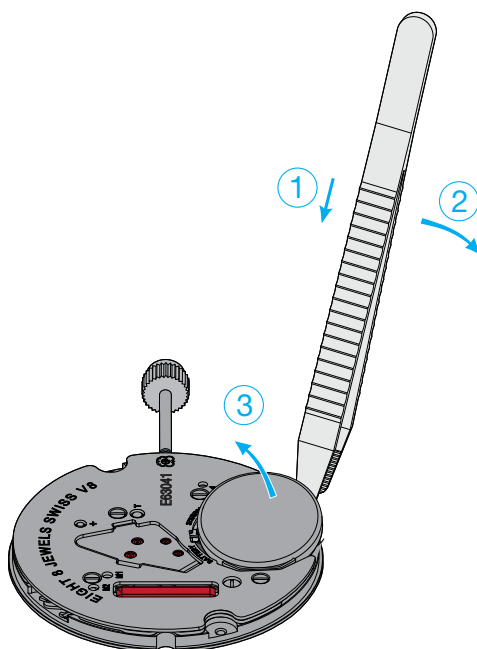

Extracting the stem

The handsetting stem must be pushed back to position 1 (neutral) before pressing on the point lying on the right sider of the setting lever.

Extracción de la tija de puesta en hora

Antes de pulsar el punto a la derecha del tirete, es obligatorio empujar la tija de puesta en hora en posición 1 (neutral).

Estrazione dell'albero di messa all'ora

Prima di premere il punto a destra del tireto, è obbligatorio premere l'albero di messa all'ora in posizione 1 (neutra).

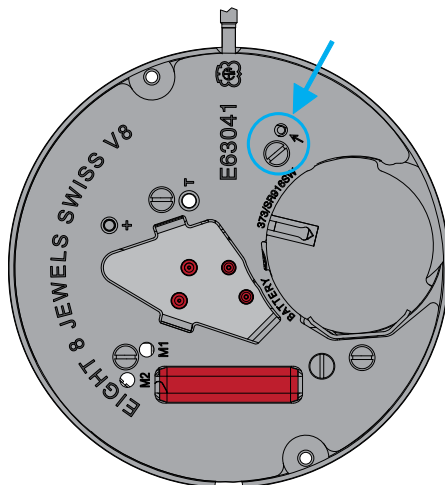



For information regarding hand fitting heights see:

Manufacturing Information

Drawing:
AIGUILLAGES
ZEIGERWERKHÖHEN
HAND FITTING HEIGHTS



Para obtener información sobre las alturas de la minutería, consulte:

Información de la producción

Plan:
AIGUILLAGES
ZEIGERWERKHÖHEN
HAND FITTING HEIGHTS



Per informazioni concernenti l'aggiustamento lancette, consultare:

Informazione di produzione

Disegno:
AIGUILLAGES
ZEIGERWERKHÖHEN
HAND FITTING HEIGHTS

This page has deliberately been left blank in case of A3 format printing.

Esta página se han dejado en blanco a propósito en caso de imprimirla en formato A3.

Questa pagina è lasciata intenzionalmente bianca in caso di stampa formato A3.

This page has deliberately been left blank in case of A3 format printing.

Esta página se han dejado en blanco a propósito en caso de imprimirla en formato A3.

Questa pagina è lasciata intenzionalmente bianca in caso di stampa formato A3.

This page has deliberately been left blank in case of A3 format printing.

Esta página se han dejado en blanco a propósito en caso de imprimirla en formato A3.

Questa pagina è lasciata intenzionalmente bianca in caso di stampa formato A3.



**TECHNICAL COMMUNICATION
COMUNICACIÓN TÉCNICA
COMUNICAZIONE TECNICA**

10 ½''' ETA E63.041

CT E63041 ESI 535323 03 22.06.2015

Modifications compared with previous document versions

Modificaciones comparadas con las versiones anteriores del documento

Modifiche comparate con le versioni precedenti del documento

Version Versión Version	Date Fecha Data	Modification	Modificación	Modifica	Page Página Pagina
03	22.06.2015	Addition symbole Precidrive	Adición símbolo Precidrive	Aggiunta simbolo Precidrive	1, 17
02	11.08.2014	New drawing	Nuevo plan	Nuovo disegno	19
01	12.04.2013	New drawing	Nuevo plan	Nuovo disegno	19
00	18.06.2012	Basic version	Versión de base	Versione di base	--

All modifications reserved.

Salvo modificación.

Con riserva di ogni eventuale modifica.

This document can be found on the Support Center Portal (SCP):

www.eta.ch

- Support Center
- Support Center Portal
- Technical Documents

Este documento se encuentran en el Support Center Portal (SCP):

www.eta.ch

- Support Center
- Support Center Portal
- Technical Documents

Il presente documento si trovano sul Support Center Portal (SCP):

www.eta.ch

- Support Center
- Support Center Portal
- Technical Documents



ETA^{SA}
MANUFACTURE HORLOGÈRE SUISSE
DEP. N. 5.1793

SC PRODUCT COMMUNICATION

Bahnhofstrasse 9
2540 Grenchen
Switzerland

Phone +41 (0)32 655 71 11
Fax +41 (0)32 655 71 74

contact@eta.ch
www.eta.ch