



8 3/4^{'''} ETA F04.111

CT F04111 FDE 296475 17 29.06.2016

8 3/4^{'''} Ø 19,40 mm

Hauteur sur mouvement	Höhe auf Werk	Movement height	2,50 mm
Hauteur sur pile	Höhe auf Batterie	Height on battery	No. 364: 2,65 mm No. 377: 3,10 mm
Nombre de rubis	Anzahl Rubine	Number of jewels	3
Fréquence	Frequenz	Frequency	32'768 Hz

Hauteur sur mouvement	Höhe auf Werk	Movement height	2,50 mm
Hauteur sur pile	Höhe auf Batterie	Height on battery	No. 364: 2,65 mm No. 377: 3,10 mm
Nombre de rubis	Anzahl Rubine	Number of jewels	3
Fréquence	Frequenz	Frequency	32'768 Hz

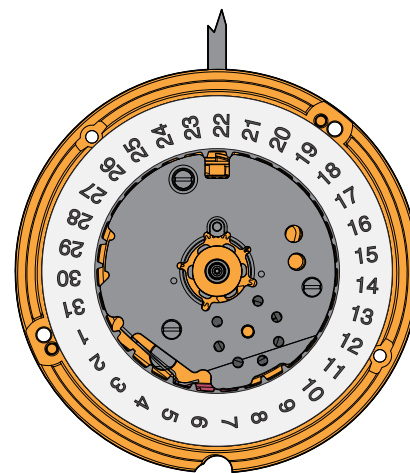
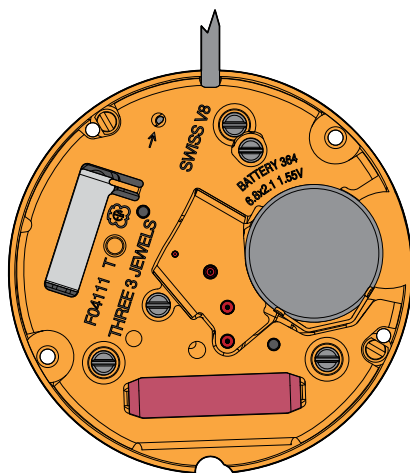

Les travaux de réparation et de révision ne doivent être effectués que par du personnel dûment formé.
Reparatur- und Revisionsarbeiten dürfen nur von ausgebildetem Fachpersonal ausgeführt werden.
The repair and reconditioning work must only be performed by properly trained personnel.



Informations générales



Avant de démarrer les travaux, veuillez svp étudier attentivement cette "*Communication technique*".



La protection des yeux est obligatoire pour toutes les interventions / tous les travaux sur le mouvement!



ETA SA décline toute responsabilité en cas de dommages du non respect de cette "*Communication technique*".

Exigences en matière de protection de l'environnement



Les dispositions légales en matière de traitement et d'élimination des déchets doivent être respectées lors de toutes les interventions / tous les travaux sur les mouvements!

En particulier, les produits de graissage et de nettoyage néfastes pour l'environnement doivent être éliminés selon les règles!



Les **substances de nature à polluer l'eau** doivent être entreposées, transportées, récupérées et éliminées dans des récipients adéquats.

Elles ne doivent en aucun cas polluer le sol ou être évacuées dans les réseaux de canalisation!

Explication des symboles



Attention! Risque de dégât matériel!

Ci-après quelques instructions à suivre obligatoirement pour éviter tout dégât matériel!



Ci-après quelques conseils d'utilisations et informations importantes.

Allgemeine Informationen



Diese "*Technische Mitteilung*" ist **vor** dem Beginn der Arbeiten genauestens zu studieren.



Für sämtliche Arbeiten am und mit dem Uhrwerk ist ein Augenschutz obligatorisch!



Für Schäden, welche durch Nichtbeachtung dieser "*Technischen Mitteilung*" entstehen, haftet die ETA SA nicht.

Umweltschutz-Vorschriften



Bei allen Arbeiten am und mit dem Uhrwerk sind die gesetzlichen Vorschriften zur ordnungsgemässen Verwertung und Beseitigung der Abfälle einzuhalten!

Insbesondere sind umweltgefährdende Schmier- und Reinigungsmittel ordnungsgemäss zu entsorgen!



Wassergefährdende Stoffe müssen in geeigneten Behältern aufbewahrt, transportiert, aufgefangen und entsorgt werden.

Diese dürfen nicht den Boden belasten oder in die Kanalisation gelangen!

Symbolerklärung



Achtung! Gefahr von Sachschäden!

Hier folgen wichtige Hinweise, die zur Vermeidung von Sachschäden unbedingt beachtet werden müssen!



Hier folgen Anwendungstipps und wichtige Informationen.

General information



Before starting work, please study this "*Technical communication*" carefully.



Eye protection is obligatory for all operations / work on the movement!



ETA SA disclaims any liability in case of damage arising from failure to observe this "*Technical communication*".

Environmental protection requirements



The legal provisions relating to waste handling and disposal must be observed in all operations / work on the movement!

In particular, lubricating and cleaning products harmful to the environment must be disposed of in accordance with the rules!



Substances prone to cause water pollution must be stored, transported, collected and disposed of in appropriate vessels.

They must not pollute the soil or be poured into sewage systems!

Explanation of symbols



Caution! Risk of material damage!

Below are some obligatory instructions for preventing any material damage!



Below are some application and important informations.

Liste des fournitures - Bestandteilliste - List of components

Pos	Numéro d'article Artikelnummer Article number		Liste des fournitures	Bestandteilliste	List of components
1	7613226008465		Platine, montée	Werkplatte, montiert	Main plate, assembled
1-1	Var	2x	Fixateur de cadran	Zifferblatthalter	Dial fastener
2	7613226042834		Pignon coulant	Kupplungstrieb	Sliding pinion
3	Var		Tige de mise à l'heure	Stellwelle	Handsetting stem
4	7613226050365		Tirette, montée	Winkelhebel, montiert	Setting lever, assembled
5	7613226005228		Bascule	Hebel	Yoke
6	7613226004764		Sautoir de tirette	Winkelhebelraste	Setting lever jumper
7	7613226013728		Stator	Stator	Stator
8	7613226015388		Entretoise du module électronique, monté	Zwischenstück für Elektronik-Baugruppe, montiert	Electronic module distance piece, assembled
9	7613226019881		Bride -	Bügel -	Bridle -
10	7613226003460		Rondelle	Unterlagscheibe	Washer
11	7613226152717		Rotor	Rotor	Rotor
12	7613226024922		Roue intermédiaire	Zwischenrad	Intermediate wheel
13	7613226030107		Roue moyenne	Kleinbodenrad	Third wheel
14	Var		Roue de seconde	Sekundenrad	Second wheel
15	7613226143753		Pont de rouage, empierré	Räderwerkbrücke, mit Steinen	Train wheel bridge, jewelled
16	7613226025097		Isolateur de pile	Isolation für Batterie	Battery insulator
17	7613226016507		Module électronique	Elektronik-Baugruppe	Electronic module
18	7613226043275		Bride +	Bügel +	Bridle +
19	7613226010284		Couvre-module électronique	Deckplatte für Elektronik-Baugruppe	Electronic module cover
20	Var		Chaussée avec roue entraîneuse	Minutenrohr mit Mitnehmerrad	Cannon pinion with driving wheel
21	7613226017276		Roue de minuterie	Wechselrad	Minute wheel
22	Var		Pont de rouage de minuterie	Wechselradbrücke	Minute train bridge
23	7613226017115		Roue des heures, montée	Stundenrad, montiert	Hour wheel, assembled
24	7613226037550		Roue entraîneuse de l'indicateur de quantité	Datumanzeiger-Mitnehmerrad	Date indicator driving wheel
25	Var		Indicateur de quantité	Datumanzeiger	Date indicator
26	7613226042605		Plaque de maintien	Halteplatte	Maintaining plate
27	Var		Pile	Batterie	Battery
28	7613226002852		Ressort de limitation de pile	Begrenzungsfeder für Batterie	Battery limiting spring
900	7613226004085	2x	Vis à tête cylindrique	Zylinderschraube	Cylindrical head screw
			- Pos. 15: Vis de pont de rouage	- Pos. 15: Schraube für Räderwerkbrücke	- Pos. 15: Screw for train wheel bridge
		3x	- Pos. 19: Vis du couvre-module électronique	- Pos. 19: Schraube für Deckplatte für Elektronik-Baugruppe	- Pos. 19: Screw for electronic module cover
901	7613226021693	1x	Vis à tête conique	Senkschraube	Countersunk head screw
			- Pos. 22: Vis de pont de rouage de minuterie	- Pos. 22: Schraube für Wechselradbrücke	- Pos. 22: Screw for minute train bridge
		3x	- Pos. 26: Vis de plaque de maintien	- Pos. 26: Schraube für Halteplatte	- Pos. 26: Screw for maintaining plate
902	7613226031937	1x	Vis à portée	Ansatzschraube	Shouldered flat head screw
			- Pos. 6: Vis de sautoir de tirette	- Pos. 6: Schraube für Winkelhebelraste	- Pos. 6: Screw for setting lever jumper
	Var		Variante	Variante	Variant

**L'interchangeabilité et les variantes se trouvent sur
ETA ONLINE SHOP (EOS) :**

www.eta.ch

- Customer Service
- Customer Service Portal

**Die Austauschbarkeit und Varianten finden Sie im
ETA ONLINE SHOP (EOS):**

www.eta.ch

- Customer Service
- Customer Service Portal

**Interchangeability and variants
can be found on the
ETA ONLINE SHOP (EOS):**

www.eta.ch

- Customer Service
- Customer Service Portal

Fournitures - Bestandteile - Materials

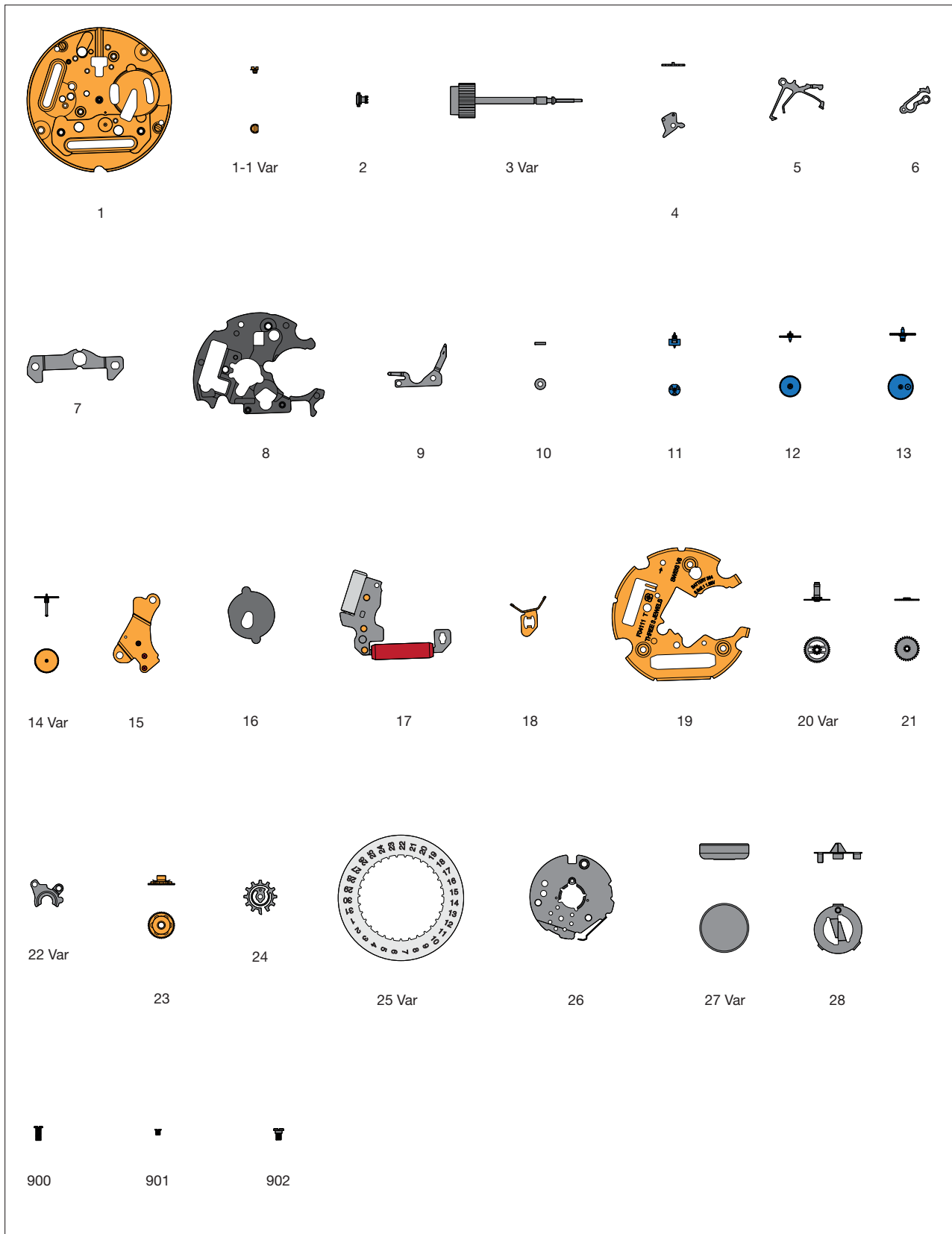

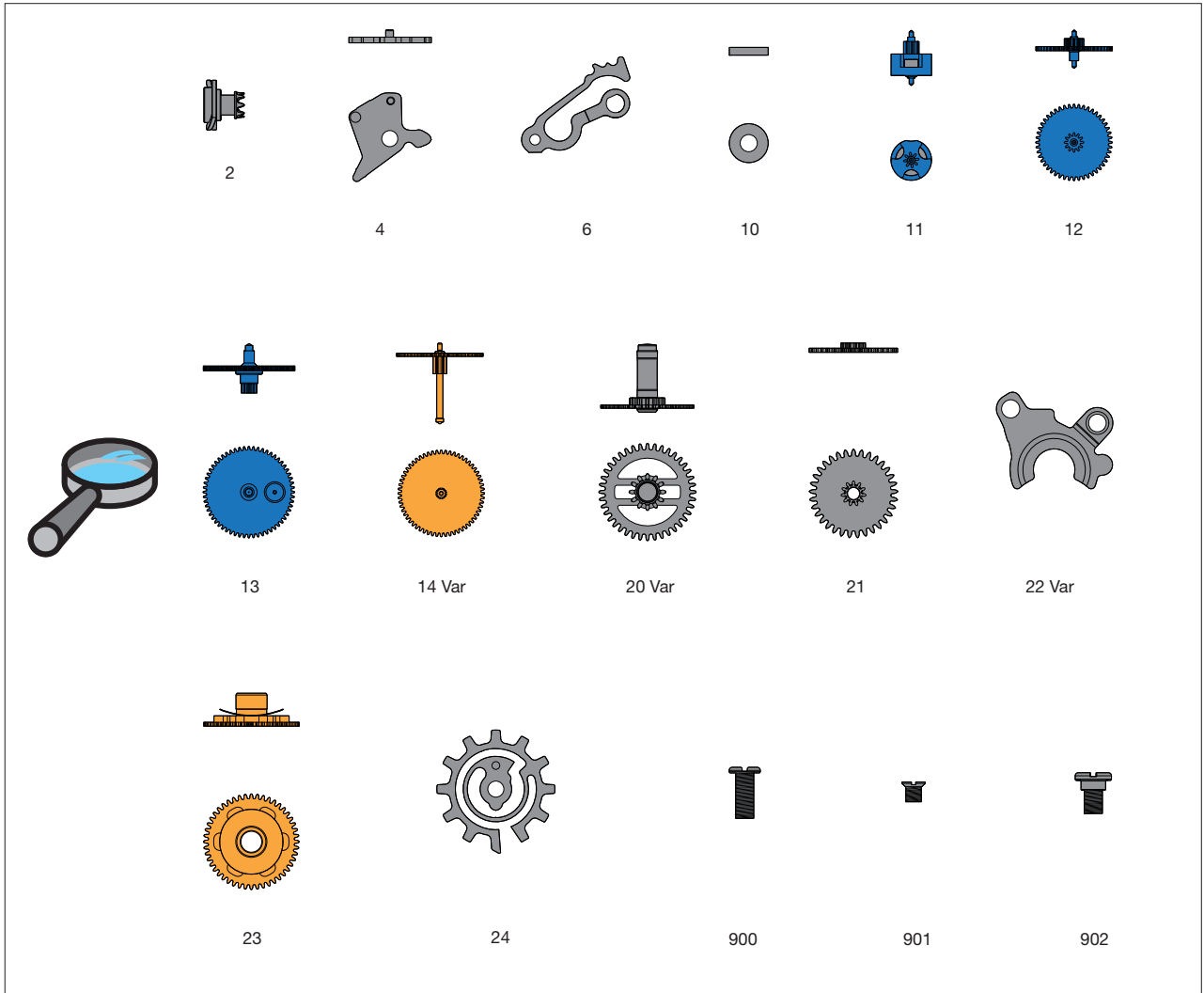

Ordre d'assemblage - Montager Reihenfolge - Order of assembly:
 Mouvement de base - Basiswerk - Basic movement

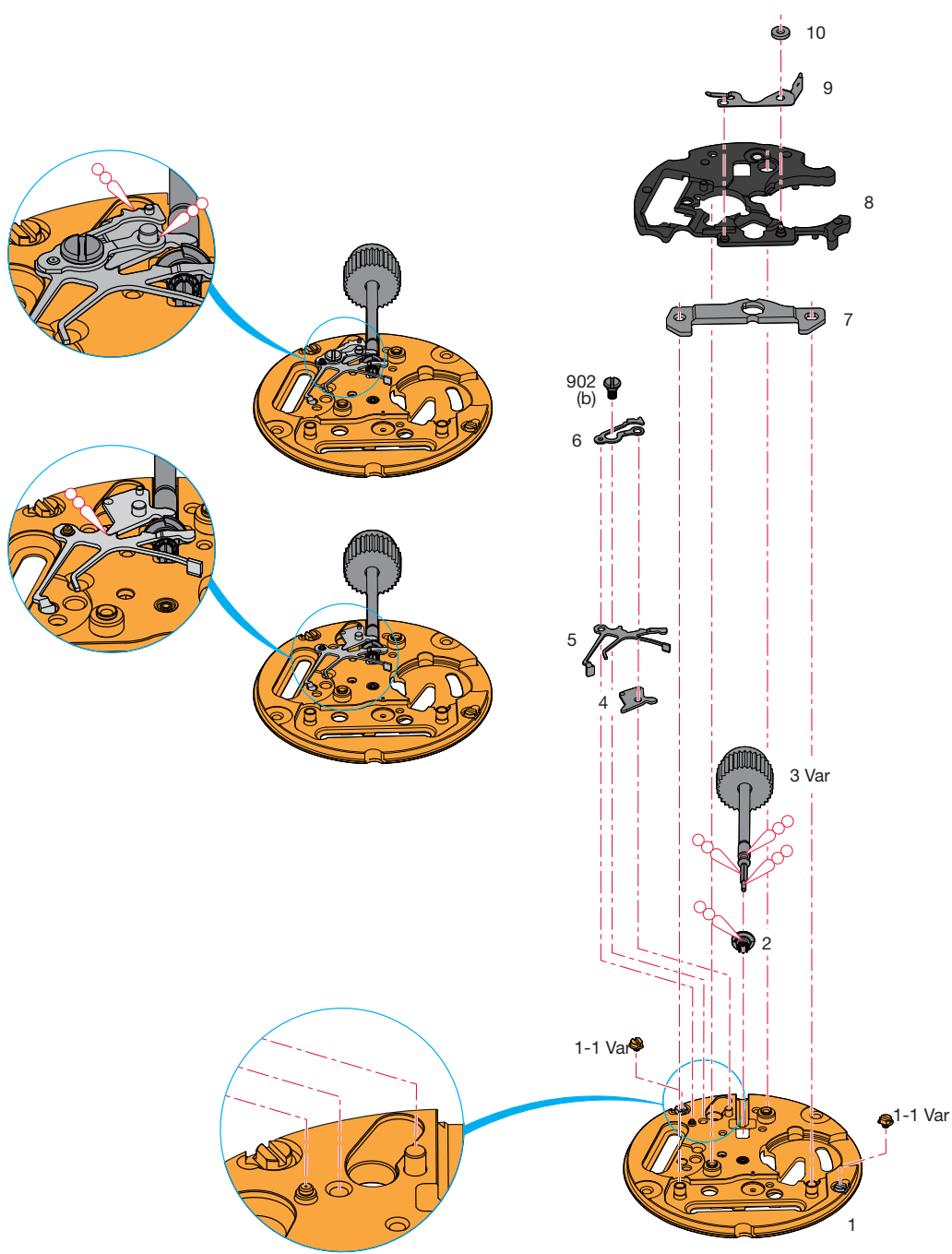

Montage du mouvement de base

(Liste des fournitures par ordre d'assemblage)

Zusammenstellen des Basiswerkes

(Bestandteilliste in Montager Reihenfolge)

Assembling of the basic movement

(Parts listed in order of assembly)

1	5	8
2	6	9
3 Var	902 (1x)	10
4	7	

Lubrification - Schmierung - Lubrication

Huile épaisse ou graisse
 Dickflüssiges Öl oder Fett
 Thick oil or grease

Moebius
HP-1300
 ou / oder / or
Moebius D5

M_L Couple minimum pour dévisser**M_L Minimales Drehmoment zum Lösen****M_L Minimum torque for loosening**

(b) 0,7 Ncm

Ordre d'assemblage - Montagerihenfolge - Order of assembly:
 Rouage - Räderwerks - Wheel train

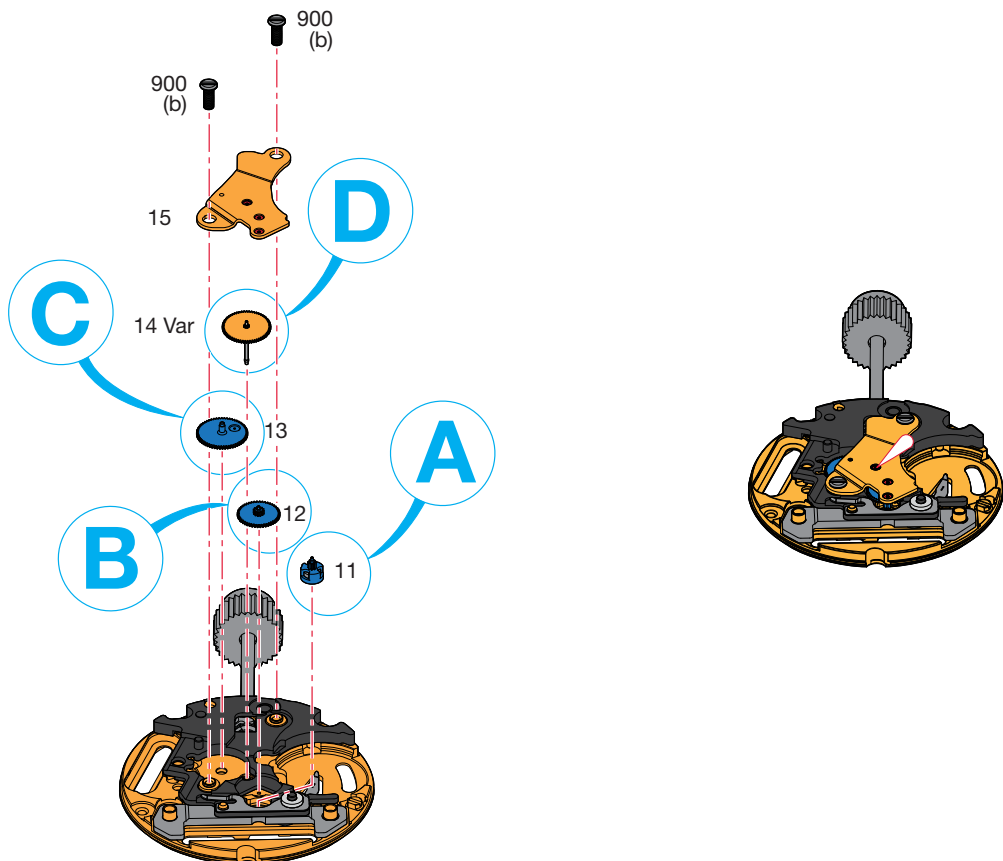
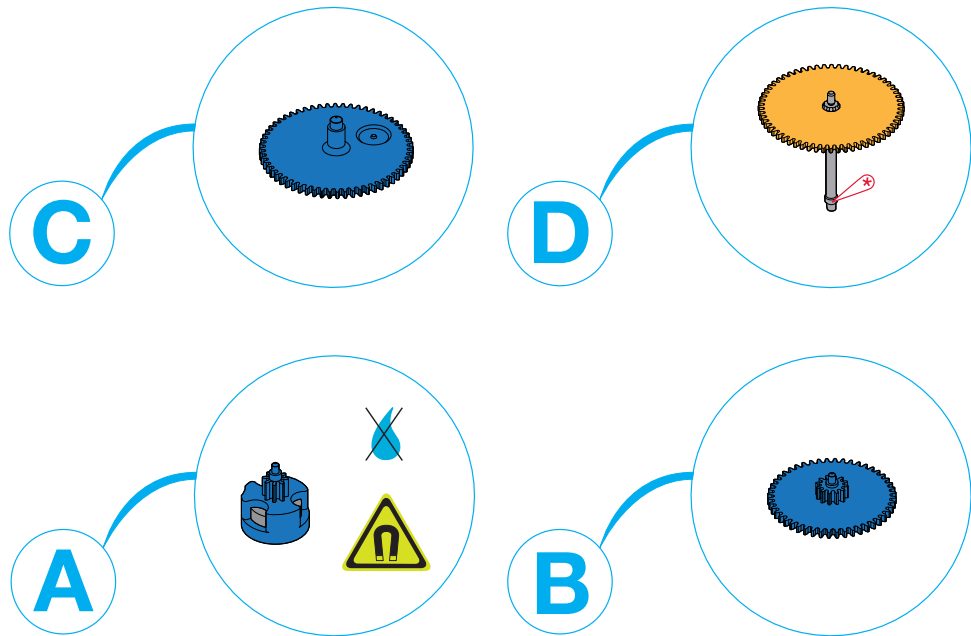

Montage du rouage

(Liste des fournitures par ordre d'assemblage)

Zusammenstellen des Räderwerks

(Bestandteilliste in Montager Reihenfolge)

Assembling of the wheel train

(Parts listed in order of assembly)

11	13	15
12	14 Var	900 (2x)

Lubrification - Schmierung - Lubrication

 Très faible quantité
Sehr kleine Menge
Very small quantity

Moebius 9014
ou / oder / or
Moebius 9034

 Huile fine
Dünnflüssiges Öl
Fine oil

Moebius 9014
ou / oder / or
Moebius 9034

 Ne pas laver. Si la pièce est très sale ou rouillée, l'échanger par une fourniture d'origine livrée pré lubrifiée par ETA SA.
Nicht waschen. Sollte das Stück sehr verschmutzt oder rostig sein, ist es gegen ein von ETA SA vorgeöltes Original-Stück zu tauschen.
Do not wash. If the part is very dirty or rusty, it should be exchanged for an original part which is lubricated and delivered by ETA SA.



Avant le montage, s'assurer qu'aucun copeau métallique ni aucune salissure n'est présent sur l'aimant.

Vor dem Montieren kontrollieren, dass keine metallischen Späne oder Verunreinigungen auf dem Magneten zurückgeblieben sind.

Before assembly, check that no metal filings or impurities have remained on the magnet.

M_L Couple minimum pour dévisser

M_L Minimales Drehmoment zum Lösen

M_L Minimum torque for loosening

(b) 0,7 Ncm

Ordre d'assemblage - Montagereihenfolge - Order of assembly:
Module électronique - Elektronik-Baugruppe - Electronic module

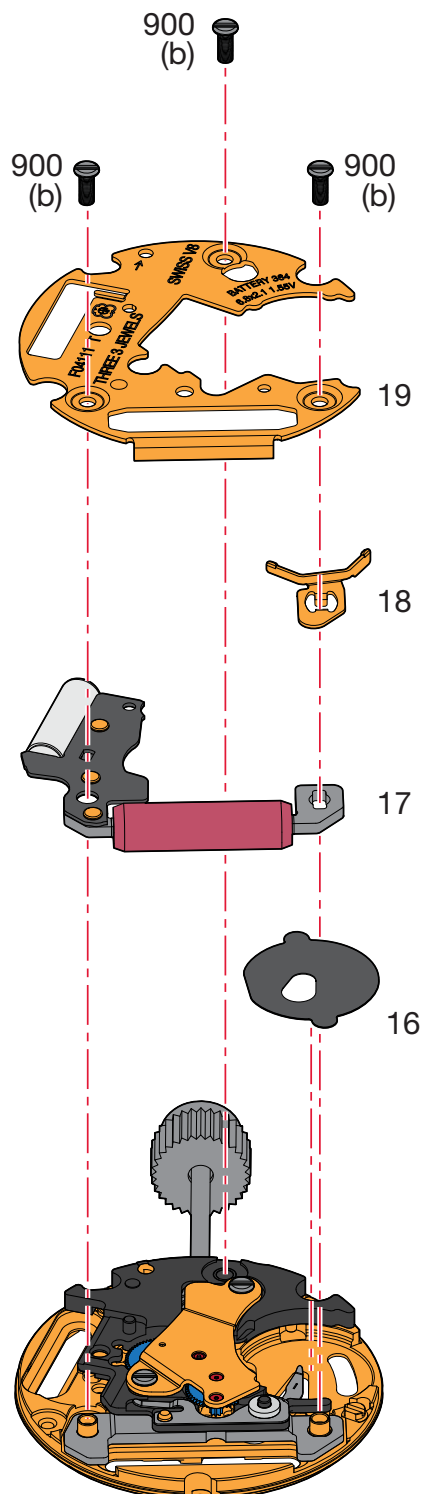

Montage du module électronique

(Liste des fournitures par ordre d'assemblage)

Zusammenstellen der Elektronik-Baugruppe

(Bestandteilliste in Montagereihenfolge)

Assembling of the electronic module

(Parts listed in order of assembly)

16	18	900 (3x)
17	19	

M_L Couple minimum pour dévisser**M_L Minimales Drehmoment zum Lösen****M_L Minimum torque for loosening**

(b) 0,7 Ncm

Ordre d'assemblage - Montager Reihenfolge - Order of assembly:
 Mécanisme de calendrier - Kalendermechanismus - Calendar mechanism

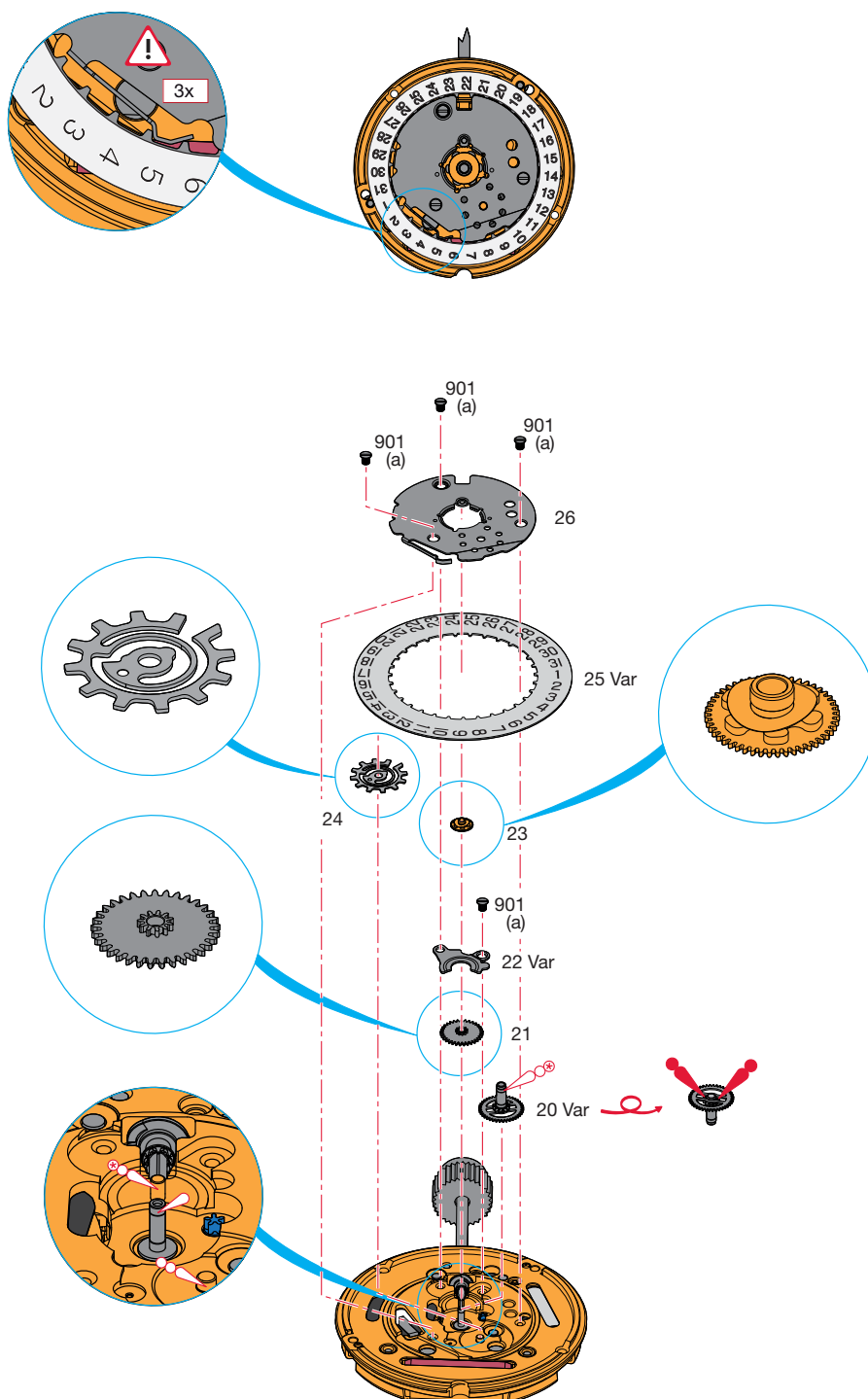

Montage du mécanisme de calendrier

(Liste des fournitures par ordre d'assemblage)

Zusammenstellen des Kalendermechanismus

(Bestandteilliste in Montagereihenfolge)

Assembling of the calendar mechanism

(Parts listed in order of assembly)

20 Var	901 (1x)	25 Var
21	23	26
22 Var	24	901 (3x)

Lubrification - Schmierung - Lubrication

 Huile fine
Dünnflüssiges Öl
Fine oil

Moebius 9014
ou / oder / or
Moebius 9034

 Huile épaisse ou graisse
Dickflüssiges Öl oder Fett
Thick oil or grease

Moebius HP-1300
ou / oder / or
Moebius D5

 Très faible quantité
Sehr kleine Menge
Very small quantity

Moebius HP-1300
ou / oder / or
Moebius D5

 Graisse
Fett
Grease

Moebius 9501
ou / oder / or
Jismaa 124

 Graisse
Fett
Grease

Molykote DX

M_L Couple minimum pour dévisser**M_L Minimales Drehmoment zum Lösen****M_L Minimum torque for loosening**

(a) 0,6 Ncm

	Lubrifier la pièce 26. 1. Teil 26 schmieren. Lubricate part 26.
	Tourner la pièce 25 d'environ 10 dents avec la correction rapide. 2. Teil 25 mit Schnellkorrektur ca. 10 Zähne drehen. Rotate part 25 approx 10 teeth with rapide correction.
	Lubrifier à nouveau la pièce 26. 3. Teil 26 nochmals schmieren. Lubricate again part 26.
	Tourner à nouveau la pièce 25 d'environ 10 dents avec la correction rapide. 4. Teil 25 nochmals mit Schnellkorrektur ca. 10 Zähne drehen. Rotate part 25 approx 10 teeth with rapide correction again.
	Lubrifier à nouveau la pièce 26. 5. Teil 26 nochmals schmieren. Lubricate again part 26.
	Tourner à nouveau la pièce 25 d'environ 10 dents avec la correction rapide. 6. Teil 25 nochmals mit Schnellkorrektur ca. 10 Zähne drehen. Rotate part 25 approx 10 teeth with rapide correction again.

Ordre d'assemblage - Montager Reihenfolge - Order of assembly:
Pile - Batterie - Battery

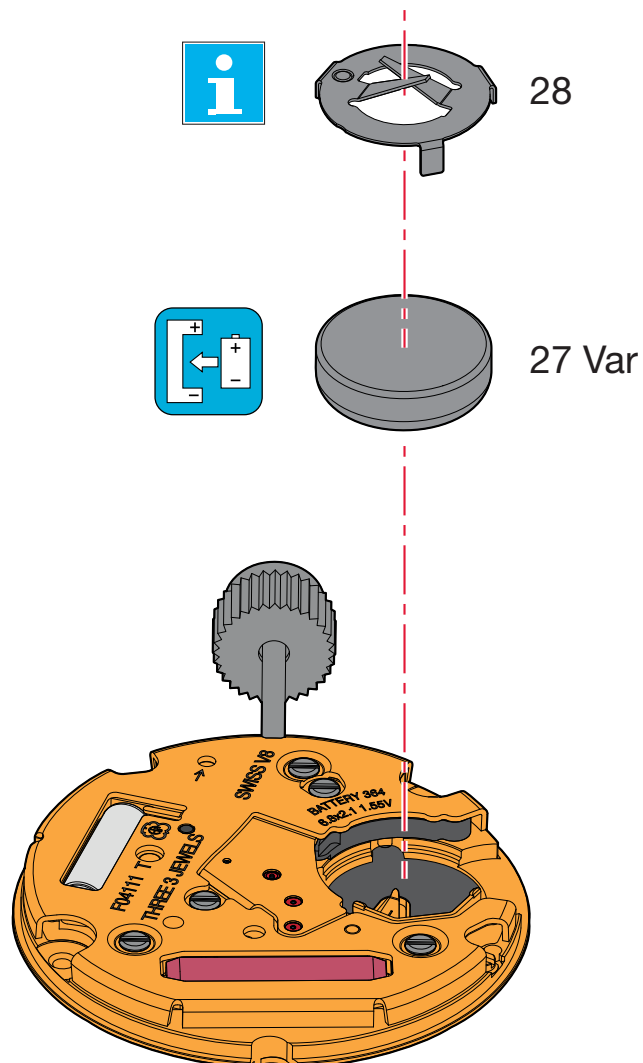

Montage de la pile

(Liste des fournitures par ordre d'assemblage)

Zusammenstellen der Batterie

(Bestandteilliste in Montagereihenfolge)

Assembling of the battery

(Parts listed in order of assembly)

27 Var

28

M_L Couple minimum pour dévisser**M_L Minimales Drehmoment zum Lösen****M_L Minimum torque for loosening**

(b) 0,7 Ncm

Pos 28:

Le ressort de limitation est nécessaire uniquement si la distance entre la pile et le fond de la boîte est trop élevée.

Pour de plus amples informations, voir:

Information Habillage
"CAGE POUR BOITE"



Die Begrenzungsfeder ist nur nötig, wenn der Abstand von der Batterie zum Gehäusoboden zu gross ist.

Für weitere Informationen siehe:

Fabrikanten Information
"UHRWERKGESTELL FÜR GEHÄUSE"

The limit spring is only necessary when the distance from the battery to the base of the casing is too far.

For further details please go to:

Manufacturing Information
"FRAME FOR CASE"

Contrôles électriques - Elektrische Kontrollen - Electrical Tests

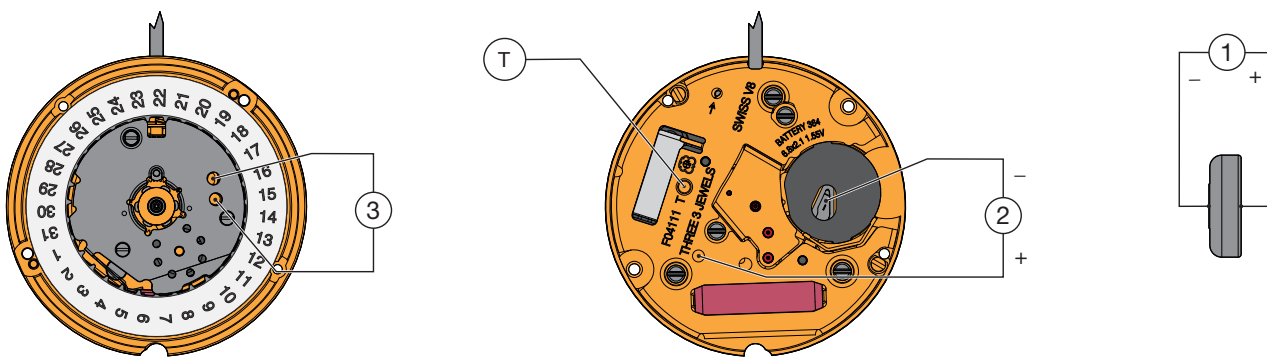

Position Messpunkt Position	Echelle de mesure Einstellung Messgerät Setting of apparatus	Mesure Messung Measurement	Contrôle Kontrolle Test	Remarques Bemerkungen Remarks
1		1,55 V	Tension de la pile Spannung der Batterie Battery voltage	
2	2 V	Saut de 4 pas toutes les 4 sec. lorsque la tension d'alimentation < 1,30 V. 4-Schritte-Sprung alle 4 Sek., wenn Speisespannung < 1,30 V. 4 steps jump every 4 sec., when feed voltage < 1.30 V.	Fonction EOL. Test de l'indication de fin de vie de pile. Funktion EOL. Test: Hinweis zur Batterieend Anzeige. EOL function. End of life test for the battery.	Mesure sans pile, avec tension d'alimentation < 1,30 V, Fonction E.O.L. après ~ 2 min. Messung ohne Batterie, mit Speisespannung < 1,30 V, E.O.L.- Funktion nach ca. 2 Min. Measurement without battery, with feed voltage < 1.30 V, E.O.L. function after about 2 min.
		Mettre en contact le point T et la piste - . Si la tension > 1,46 V, commande du moteur avec 8 pas/s. Si la tension < 1,30 V, commande du moteur avec 32 pas/s. T Punkt mit der - Spur verbinden. Wenn die Spannung > 1,46 V, Motorantrieb mit 8 Schritten/s. Wenn die Spannung < 1,30 V, Motorantrieb mit 32 Schritten/s. Connect T point with the - conductor. If the voltage is > 1,46 V, motor driven with 8 steps/s. If the voltage is < 1,30 V, motor driven with 32 steps/s.	Limite inférieure de la tension de fonctionnement. Untere Funktionsspannungsgrenze. Lower working-voltage limit.	Mesure sans pile, alimentation extérieure variable, en descendant de 1,55 V à l'arrêt du mouvement. Messung ohne Batterie mit variabler Speisung von aussen, Spannung von 1,55 V reduzieren bis zum Stillstand des Werkes. Measurement without battery, with variable external power supply, starting with 1.55 V, lower tension until movement stops.
	10 µA	≤ 1,20 µA ≤ 0,5 µA	Consommation du mouvement. Stromaufnahme Uhrwerk. Consumption of movement. Fonctionnement de l'interrupteur en pos. 3 de la tige de mise à l'heure. Funktion des Stopphebels, Pos. 3 der Zeigerstellwelle. Function of stop lever, pos. 3 of handsetting stem.	Mesure sans pile, avec alimentation extérieure 1,55 V. Messung ohne Batterie, mit Speise- gerät 1,55 V. Measurement without battery, with external power supply 1.55 V. Mesure sans pile, avec alimentation extérieure 1,55 V. Messung ohne Batterie, mit Speise- gerät 1,55 V. Measurement without battery, with external power supply 1.55 V.

Position Messpunkt Position	Echelle de mesure Einstellung Messgerät Setting of apparatus	Mesure Messung Measurement	Contrôle Kontrolle Test	Remarques Bemerkungen Remarks
3	1 V ($R_i \geq 10 \text{ k}\Omega/\text{V}$)	L'aiguille du multimètre oscille en sens + et –. Zeiger im Messgerät pulsiert im + und – Sinn. Hand of measuring apparatus oscillates in + and – direction.	Impulsion à la sortie du circuit intégré: 1 par seconde. Ausgangsimpulse am integrierten Schaltkreis: 1 pro Sekunde. Impulses at output of integrated circuit: 1 every second.	Mesure avec une pile. Messung mit Batterie. Measurement with battery.
<i>Les tests doivent être effectués dans une température ambiante entre 20° C et 25° C. Die Tests sind bei einer Umgebungstemperatur zwischen 20° C und 25° C durchzuführen. The tests must be conducted at an ambient temperature of between 20° C and 25° C.</i>				

Remarque:

Pour avoir accès aux bornes de la bobine et pouvoir détecter l'impulsion moteur, il faut venir avec deux pointes très fines contacter les deux plages selon le point 3 du dessin ci-dessus.

Bemerkung:

Um auf die Magnetspulen zugreifen und den Motorimpuls orten zu können, müssen die beiden Flächen gemäss Punkt 3 auf der oben stehenden Zeichnung mit zwei sehr feinen Spitzen berührt werden.

Note:

In order to access the stops of the spool and detect the motor pulse, use two very fine points to contact the two jumper plugs as shown in point 3 of the above diagram.

Pose de la pile

Glisser la pile contre la bride de contact ①. Presser la pile au fond de son logement ②. La bride + maintient la pile en place.

La pincette ne doit pas être conductrice d'électricité!

Batterie einsetzen

Die Batterie gegen den Batteriehaltebügel ① einlegen. Danach die Batterie in das Batteriefach drücken ②. Der Finger des Bügels + fixiert die Batterie in der Halterung.

Die Pinzette darf nicht elektrisch leitend sein!

Fitting the battery

Slide the battery against the contact strip ①. Press the battery firmly into its mounting ②. The bridle + keeps the battery in position.

The tweezers must not be electrically conductive!

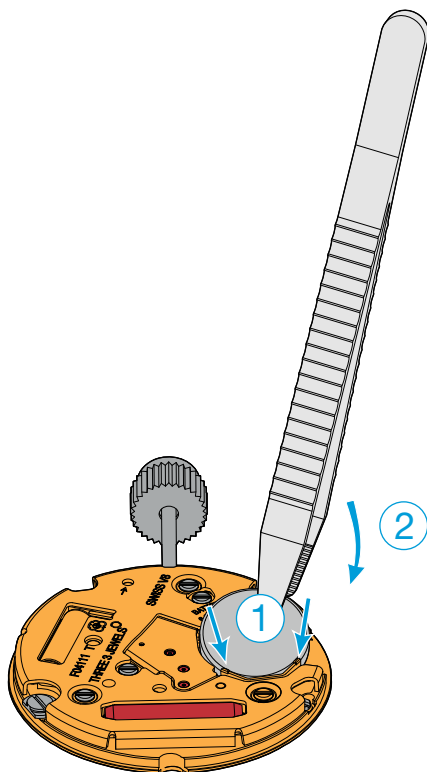

Retrait de la pile

Glisser une brucelle ① entre la platine et la pile (voir dessin) et faire levier sous celle-ci en écartant très légèrement la bride + vers le haut ②. Sortir la pile ③.

La pincette ne doit pas être conductrice d'électricité!

Batterie herausnehmen

Führen Sie eine Pinzette ① zwischen Werkplatte und Batterie ein (siehe Abbildung). Heben Sie die Batterie mit leichtem Druck nach oben ②. Nehmen Sie die Batterie ③ heraus.

Die Pinzette darf nicht elektrisch leitend sein!

Removing the battery

Insert tweezers ① between main plate and battery (see drawing) and lift out the battery by gently lifting back ②. Remove the battery ③.

The tweezers must not be electrically conductive!

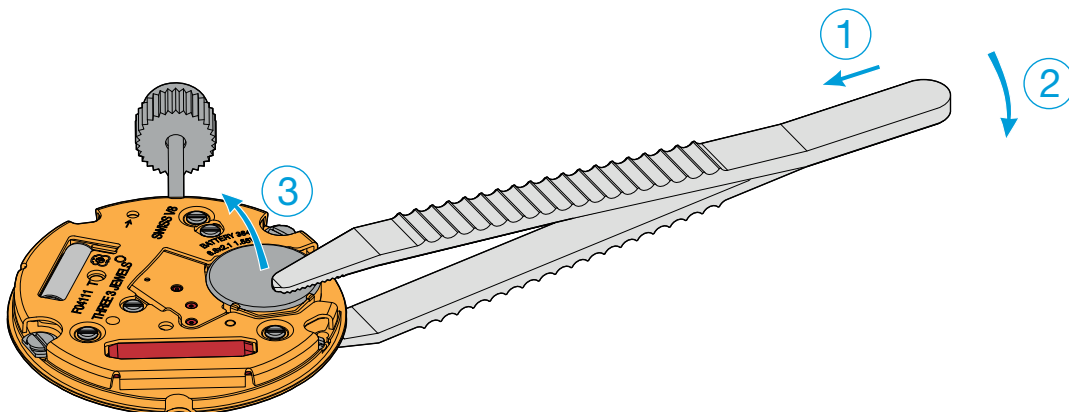

Extraction de la tige de mise à l'heure

Repousser obligatoirement la tige de mise à l'heure en position 1 (neutre) avant de presser sur le point à gauche de la tirette.

Entfernen der Stellwelle

Erst die Stellwelle in Position 1 (neutral) drücken, dann zum Lösen der Stellwelle auf den Punkt links auf dem Winkelhebel drücken.

Extracting the stem

The handsetting stem must be pushed back to position 1 (neutral) before pressing on the point lying on the left sider of the setting lever.

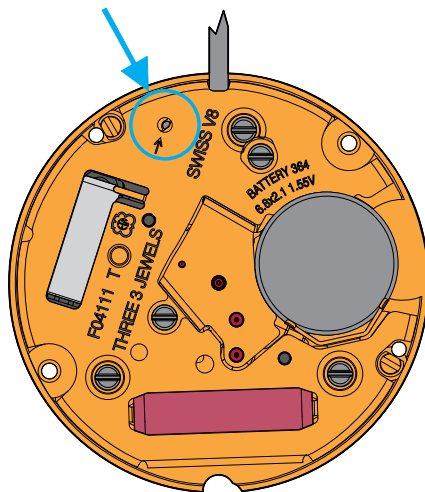



Pour des informations concernant les aiguillages voir:

Information Habillage

Plan:
*AIGUILLAGES
ZEIGERWERKHÖHEN
HAND FITTING HEIGHTS*



Für Informationen betreffend der Zeigerwerkhöhen siehe:

Fabrikanten Information

Zeichnung:
*AIGUILLAGES
ZEIGERWERKHÖHEN
HAND FITTING HEIGHTS*



For information regarding hand fitting heights see:

Manufacturing Information

Drawing:
*AIGUILLAGES
ZEIGERWERKHÖHEN
HAND FITTING HEIGHTS*

Cette page est laissée vide
intentionnellement en cas d'impression
au format A3.

Diese Seite wird absichtlich leer
gelassen für den Fall, dass im
A3-Format gedruckt wird.

This page has deliberately been
left blank in case of A3 format
printing.

Cette page est laissée vide
intentionnellement en cas d'impression
au format A3.

Diese Seite wird absichtlich leer
gelassen für den Fall, dass im
A3-Format gedruckt wird.

This page has deliberately been
left blank in case of A3 format
printing.

Cette page est laissée vide
intentionnellement en cas d'impression
au format A3.

Diese Seite wird absichtlich leer
gelassen für den Fall, dass im
A3-Format gedruckt wird.

This page has deliberately been
left blank in case of A3 format
printing.

**Modifications comparées aux versions
précédentes du document****Änderungen gegenüber vorher-
gehenden Dokumentversionen****Modifications compared with previous
document versions**

Version	Date Datum Date	Modification	Änderung	Modification	Page Seite Page
17	29.06.2016	Fournitures pos. 13	Bestandteile Pos. 13	Materials pos. 13	4-5
16	17.09.2015	Chapitre contrôles électriques	Kapitel Elektrische Leistungen	Chapter electrical tests	16
15	06.08.2014	Nouveaux plans	Neue Zeichnungen	New drawings	20-21
14	30.06.2014	Nouveau plan	Neue Zeichnung	New drawing	20
		Adaptation variante et numéro GTIN	Anpassung Variante und GTINnr.	Adaptation variant and GTIN number	3-6, 10
13	10.01.2014	Correction texte	Textkorrektur	Text correction	13
12	25.09.2013	Correction ordre des fournitures	Reihenfolge Bestandteile	Order of spare parts correction	3
		Nouvelles illustrations	Neue Illustrationen	New illustrations	1, 4-14
		Nouveau chapitre	Neues Kapitel	New chapter	18-19
11	03.04.2013	Ajout lubrification sur dessin	Zusatz Schmierem auf Zeichnung	Addition lubrication on drawing	10-11
		Nouveaux plans	Neue Zeichnungen	New drawings	14-15
10	14.01.2013	Nouveaux plans	Neue Zeichnungen	New drawings	14
09	19.06.2012	Nouveau plan	Neue Zeichnung	New drawing	14
08	28.01.2011	Corrections position 2	Messpunkt 2 Korrekturen	Position 2 corrections	12
		Correction EOL: position 2	Korrektur EOL: Messpunkt 2	Correction EOL: position 2	12
07	30.11.2010	Modification impulsions	Änderung Impulse	Modification impulses	12
06	04.11.2009	Ajout des no GTIN	Ergänzung Nr. GTIN	Addition number GTIN	2
05	08.04.2009	Ajout bride et rondelle	Ergänzung Bügel und Unterlagsscheibe	Addition bridle and washer	2-3
		Nouveau dessin (pièce No 8)	Neue Zeichnung (Teil Nr. 8)	New drawing (Part No 8)	3
		Nouvelles illustrations	Neue Illustrationen	New illustrations	4-6

Sous réserve de toutes modifications.

Änderungen vorbehalten.

All modifications reserved.

**Ce document se trouve sur le
Customer Service Portal (CSP) :****www.eta.ch**

- Customer Service
- Customer Service Portal
- Documents techniques

**Dieses Dokument finden Sie im
Customer Service Portal (CSP) :****www.eta.ch**

- Customer Service
- Customer Service Portal
- Technische Dokumente

**This document can be found on the
Customer Service Portal (CSP):****www.eta.ch**

- Customer Service
- Customer Service Portal
- Technical Documents



ETA^{SA}
MANUFACTURE HORLOGÈRE SUISSE
DEPUI 5.1793

SC MARKETING & COMMUNICATION

Bahnhofstrasse 9
2540 Grenchen
Switzerland

Phone +41 (0)32 655 71 11
Fax +41 (0)32 655 71 74

contact@eta.ch
www.eta.ch



8 3/4" ETA F04.111

CT F04111 ESI 451577 17 29.06.2016

8 3/4" Ø 19,40 mm

Movement height	Altura sobre máquina	Altezza sopra movimento	2,50 mm
Height on battery	Altura sobre pila	Altezza sopra pila	No. 364: 2,65 mm No. 377: 3,10 mm
Number of jewels	Número de piedras	Numero di pietre	3
Frequency	Frecuencia	Frequenza	32'768 Hz

Movement height	Altura sobre máquina	Altezza sopra movimento	2,50 mm
Height on battery	Altura sobre pila	Altezza sopra pila	No. 364: 2,65 mm No. 377: 3,10 mm
Number of jewels	Número de piedras	Numero di pietre	3
Frequency	Frecuencia	Frequenza	32'768 Hz

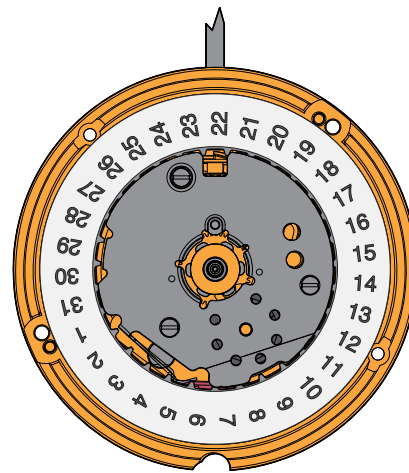
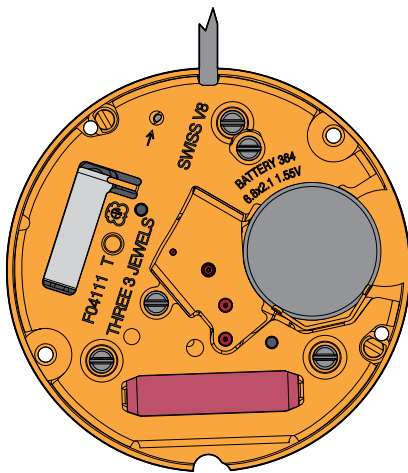

The repair and reconditioning work must only be performed by properly trained personnel.
Las tareas de reparación y revisión sólo deben ser llevadas a cabo por personal debidamente formado.
I lavori di riparazione e di revisione devono essere eseguiti esclusivamente da personale adeguatamente formato.



General information



Before starting work, please study this "Technical communication" carefully.



Eye protection is obligatory for all operations / work on the movement!



ETA SA disclaims any liability in case of damage arising from failure to observe this "Technical communication".

Environmental protection requirements



The legal provisions relating to waste handling and disposal must be observed in all operations / work on the movement!

In particular, lubricating and cleaning products harmful to the environment must be disposed of in accordance with the rules!



Substances prone to cause water pollution must be stored, transported, collected and disposed of in appropriate vessels.

They must not pollute the soil or be poured into sewage systems!

Explanation of symbols



Caution! Risk of material damage!

Below are some obligatory instructions for preventing any material damage!



Below are some application tips and important informations.

Información general



Esta "Comunicación técnica" deberá estudiarse muy bien **antes** de comenzar los trabajos.



Es obligatorio utilizar protección ocular para todos los trabajos en y con el reloj.



ETA SA no se hace responsable de los daños provocados como consecuencia de la inobservancia de esta "Comunicación técnica".

Normas de protección medioambiental



Deberá cumplirse la normativa legal relativa al reciclaje y la eliminación correctos de los residuos en todos los trabajos en y con el reloj.

En especial, deberán eliminarse correctamente los productos lubricantes y de limpieza peligrosos para el medio ambiente.



Las sustancias contaminantes del agua deben recogerse, almacenarse, transportarse y eliminarse en recipientes adecuados.

En ningún caso se permitirá que contaminen el suelo o que lleguen a la canalización.

Significado de los símbolos



Atención Peligro de daños materiales

Instrucciones que deberán respetarse necesariamente para evitar daños materiales.



Consejos de aplicación e información importantes.

Informazioni generali



Questa "Comunicazione Tecnica" deve essere studiata attentamente **prima** dell'inizio dei lavori.



Per tutti i lavori su e con il movimento dell'orologio è obbligatorio proteggere gli occhi!



ETA SA declina qualunque responsabilità per eventuali danni causati dalla mancata osservanza della presente "Comunicazione tecnica".

Disposizioni relative alla protezione ambientale



Per tutti i lavori su e con il movimento dell'orologio si dovranno rispettare le disposizioni di legge relative al corretto riciclaggio e smaltimento dei rifiuti!

In particolare si dovrà provvedere al corretto smaltimento di lubrificanti e detergenti nocivi per l'ambiente!



Le sostanze inquinanti per l'acqua devono essere conservate, trasportate, raccolte e smaltite in contenitori adatti.

Queste non devono inquinare il terreno o arrivare nelle canalizzazioni!

Spiegazione dei simboli



Attenzione! Pericolo di danni materiali!

Seguono importanti indicazioni che devono essere tassativamente rispettate per evitare danni materiali!



Seguono consigli per l'uso e informazioni importanti.

List of components - Lista de piezas - Lista fornitori

Pos	Article number Número de artículo Numero articolo		List of components	Lista de piezas	Lista fornitori
1	7613226008465		Main plate, montée	Platina, montiert	Piastra, assembled
1-1	Var	2x	Dial fastener	Sujetador de cuadrante	Ferma-quadrante
2	7613226042834		Sliding pinion	Piñón corredizo	Pignone scorrevole
3	Var		Handsetting stem	Tija de puesta en hora	Albero di messa all'ora
4	7613226050365		Setting lever, assembled	Tirete, ajustado	Tiretto, montato
5	7613226005228		Yoke	Báscula de piñón corredizo	Bascula del pignone scorrevole
6	7613226004764		Setting lever jumper	Muelle flexible de tirete	Scatto del tiretto
7	7613226013728		Stator	Estator	Statore
8	7613226015388		Electronic module distance piece, assembled	Tirante del módulo electrónico, montado	Spessore del modulo elettronico, montato
9	7613226019881		Bridle -	Brida -	Brida -
10	7613226003460		Washer	Rodaja	Rondella
11	7613226152717		Rotor	Rotor	Rotore
12	7613226024922		Intermediate wheel	Rueda intermedia	Ruota intermedia
13	7613226030107		Third wheel	Rueda primera	Ruota mediana
14	Var		Second wheel	Rueda de segundos	Ruota dei secondi
15	7613226143753		Train wheel bridge, jewelled	Puente de rodaje, empedrado	Ponte del ruotismo, con pietre
16	7613226025097		Battery insulator	Aislador de pila	Isolatore della pila
17	7613226016507		Electronic module	Módulo electrónico	Modulo elettronico
18	7613226043275		Bridle +	Brida +	Brida +
19	7613226010284		Electronic module cover	Cubre-módulo electrónico	Copri-modulo elettronico
20	Var		Cannon pinion with driving wheel	Cañón con rueda de arrastre	Pignone calzante con ruota conduttrice
21	7613226017276		Minute wheel	Rueda de minutería	Ruota della minuteria
22	Var		Minute train bridge	Puente del rodaje de minutería	Ponte del ruotismo di minuteria
23	7613226017115		Hour wheel, assembled	Rueda de horas, ajustada	Ruota delle ore, montata
24	7613226037550		Date indicator driving wheel	Rueda de arrastre del indicador de fecha	Ruota conduttrice dell'indicatore della data
25	Var		Date indicator	Indicador de fecha	Indicatore della data
26	7613226042605		Maintaining plate	Placa de sujeción	Placca di guardia
27	Var		Battery	Pila	Pila
28	7613226002852		Battery limiting spring	Muelle de limitación de pila	Molla di limitazione della pila
900	7613226004085	2x 3x	Cylindrical head screw - Pos. 15: Screw for train wheel bridge - Pos. 19: Screw for electronic module cover	Tornillo de cabeza cilíndrica - Pos. 15: Tornillo del puente de rodaje - Pos. 19: Tornillo del cubre-módulo electrónico	Vite a testa cilíndrica - Pos. 15: Vite del ponte del ruotismo - Pos. 19: Vite del copri-modulo elettronico
901	7613226021693	1x	Countersunk head screw - Pos. 22: Screw for minute train bridge	Tornillo de cabeza cónica - Pos. 22: Tornillo del puente de rodaje de minutería	Vite a testa cónica - Pos. 22: Vite del ponte del ruotismo di minuteria
902	7613226031937	3x 1x	Shouldered flat head screw - Pos. 26: Screw for maintaining plate - Pos. 6: Screw for setting lever jumper	Tornillo de asiento, cabeza chata - Pos. 26: Tornillo de placa de sujeción - Pos. 6: Tornillo de muelle flexible de tirete	Vite con piano di appoggio, testa piana - Pos. 26: Vite della placca di guardia - Pos. 6: Vite del scatto del tiretto
	Var		Variant	Variante	Variante

Interchangeability and variants can be found on the ETA ONLINE SHOP (EOS):

www.eta.ch

- Customer Service
- Customer Service Portal

La intercambiabilidad y las variantes se encuentran en ETA ONLINE SHOP (EOS):

www.eta.ch

- Customer Service
- Customer Service Portal

L'intercambiabilità e le varianti si trovano sul ETA ONLINE SHOP (EOS):

www.eta.ch

- Customer Service
- Customer Service Portal

Materials - Fornituras - Forniture

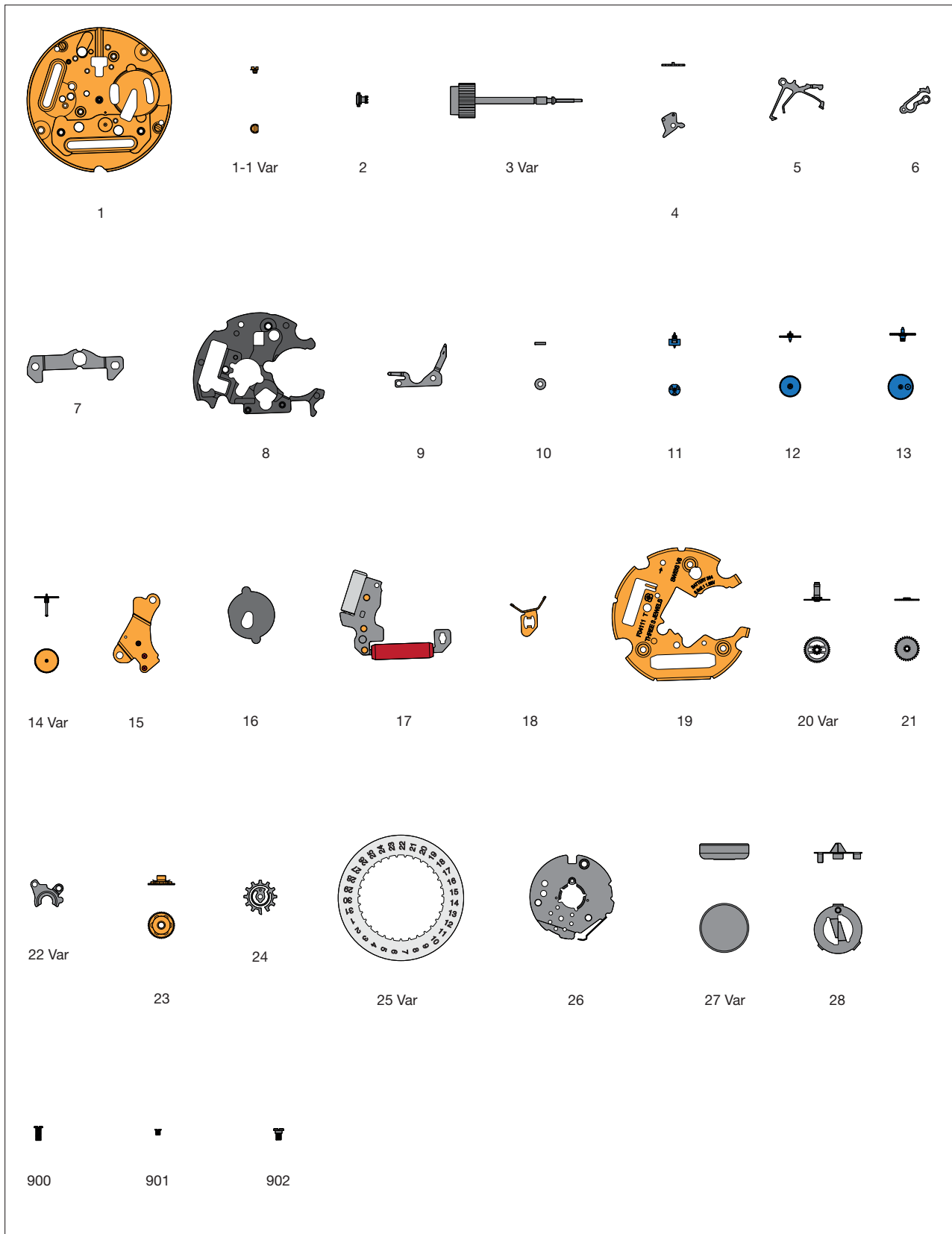

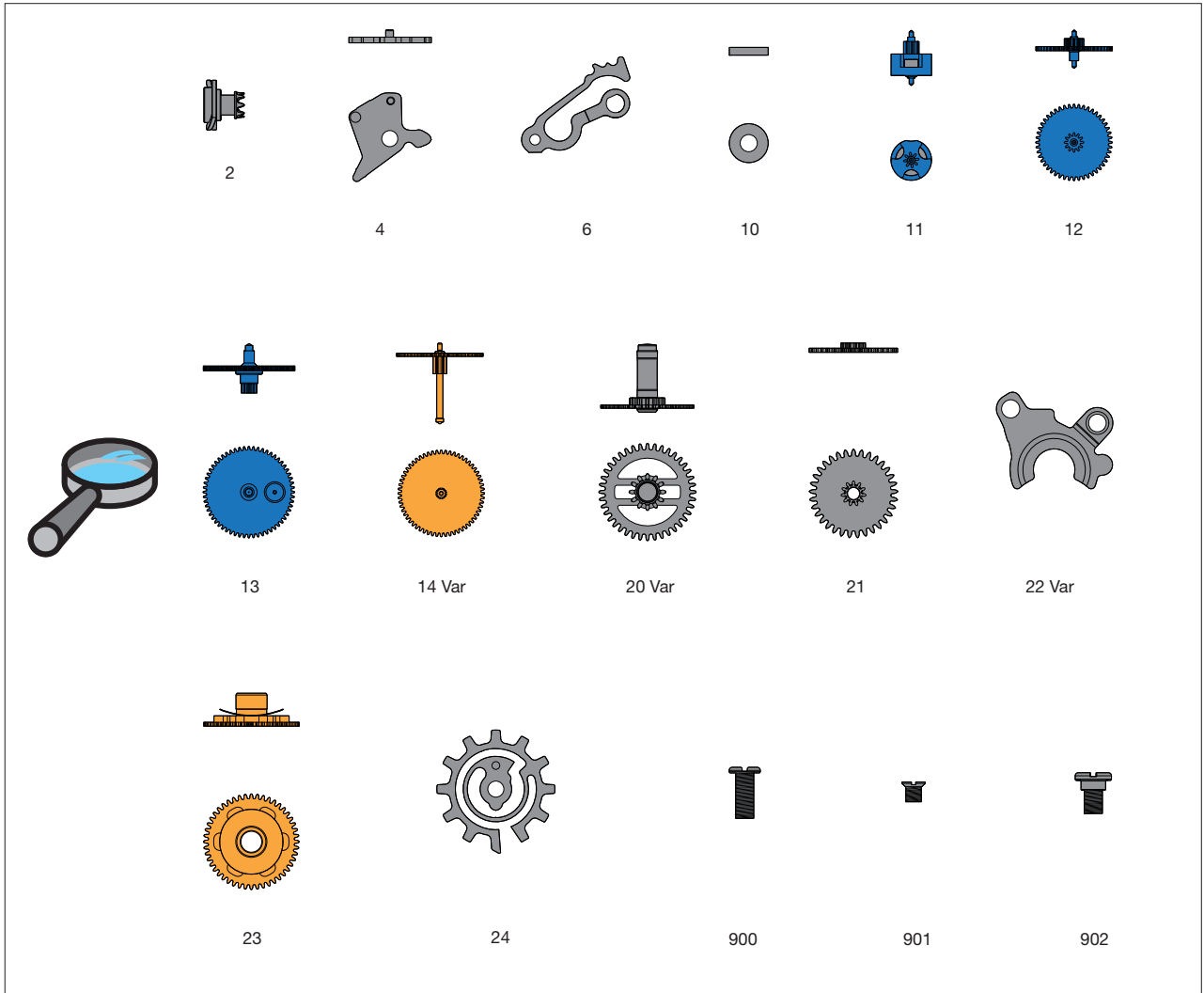

Order of assembly - Orden del montaje - Ordine dell'assemblaggio:
 Basic movement - Máquina de base - Movimento di base

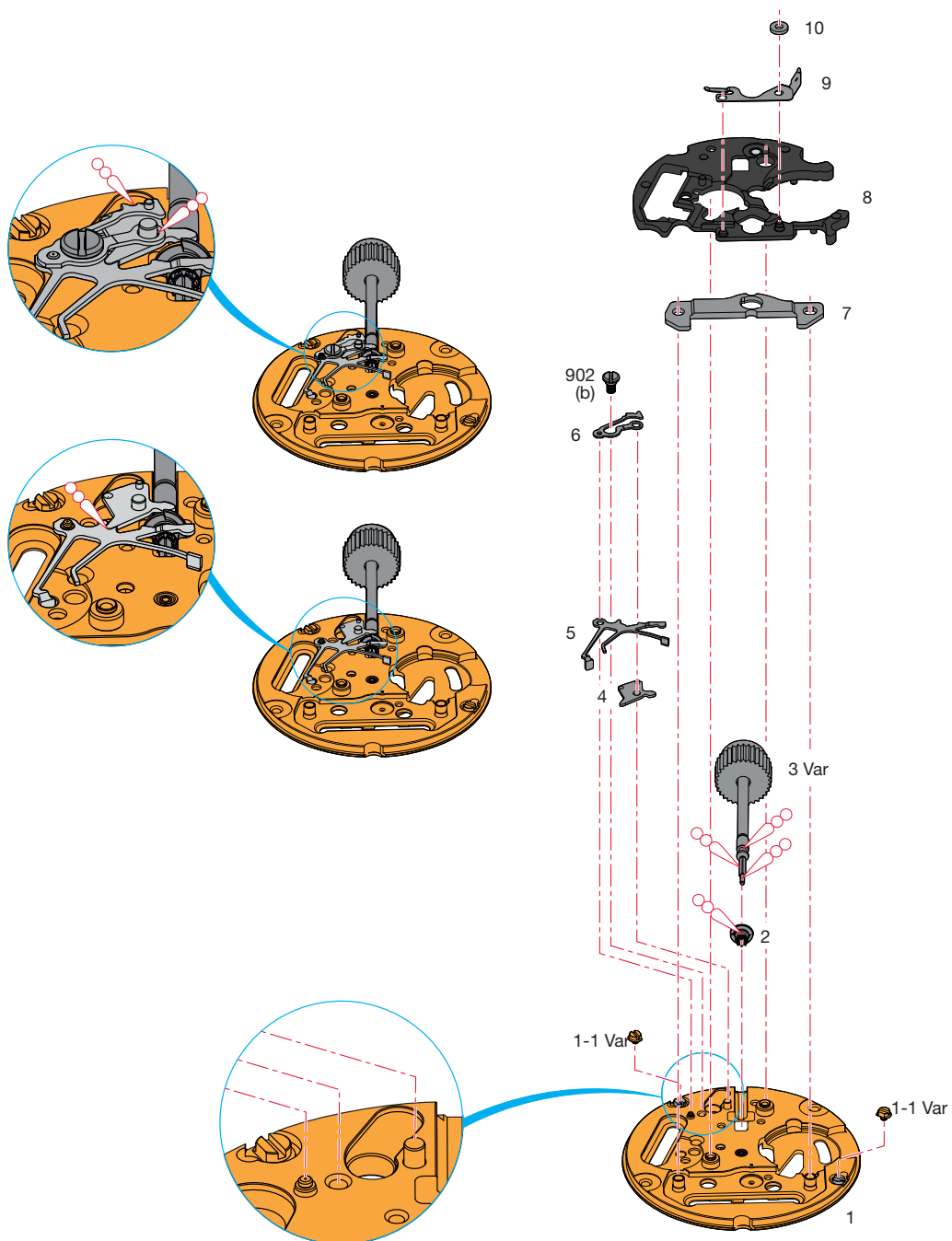

Assembling of the basic movement

(Parts listed in order of assembly)

Montaje de la máquina de base

(Lista de fornitureas por orden de ensamblado)

Montaggio del movimento di base

(Elenco delle forniture in ordine di montaggio)

1	5	8
2	6	9
3 Var	902 (1x)	10
4	7	

Lubrication - Lubricación - Lubrificazione

Thick oil or grease
Aceite espeso o grasa
Olio denso o grasso

Moebius
HP-1300
or / ó / o
Moebius D5

M_L Minimum torque for loosening**M_L Par mínimo para desatornillar****M_L Coppia minima per svitare**

(b) 0,7 Ncm

Order of assembly - Orden del montaje - Ordine dell'assemblaggio:
 Wheel train - Rodaje - Ruotismo

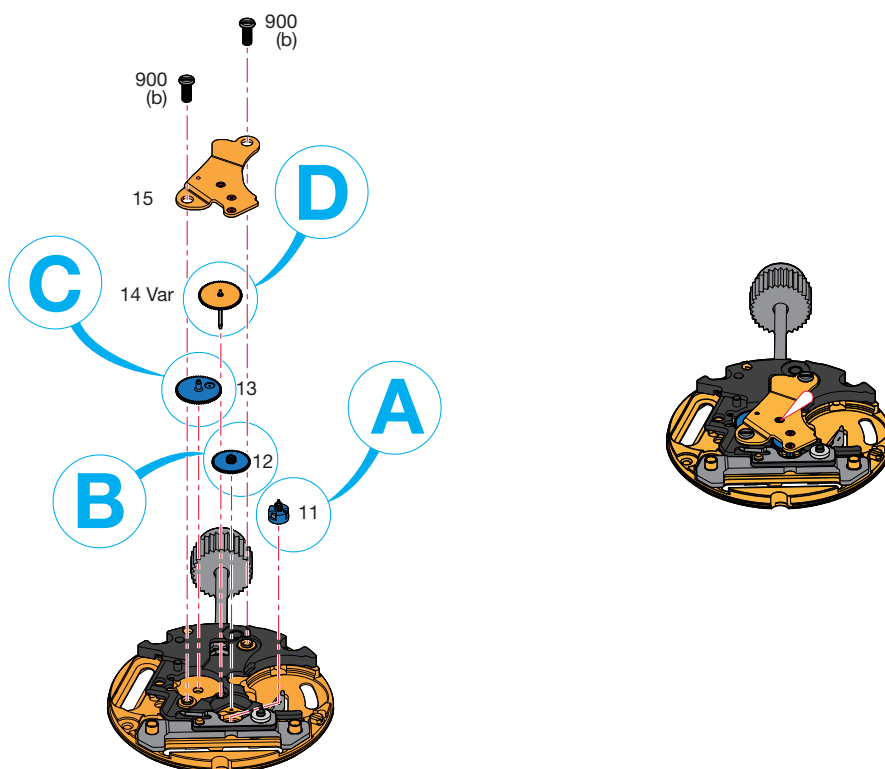
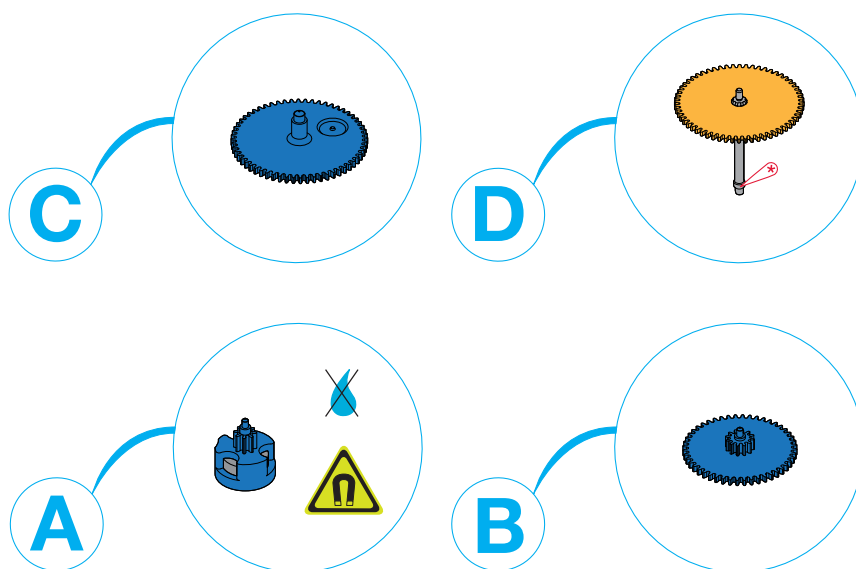

Assembling of the wheel train

(Parts listed in order of assembly)

Montaje del rodaje

(Lista de fornitureas por orden de ensamblado)

Montaggio del ruotismo

(Elenco delle forniture in ordine di montaggio)

11	13	15
12	14 Var	900 (2x)

Lubrication - Lubricación - Lubrificazione

 Very small quantity **Moebius 9014**
Cantidad muy pequeña or / ó / o
Piccolissima quantità **Moebius 9034**

 Fine oil **Moebius 9014**
Aceite fino or / ó / o
Olio fluido **Moebius 9034**



Do not wash. If the part is very dirty or rusty, it should be exchanged for an original part which is lubricated and delivered by ETA SA.

Na lavar. Si la pieza está muy sucia o herrumbrosa, cambiar por una forniturea de origen entregada lubricada por ETA SA.

Non lavare. Se il pezzo è molto sporco arrugginito, sostituire con una forniturea di origine fornita lubrificata da ETA SA.



Before assembly, check that no metal filings or impurities have remained on the magnet.

Antes del montaje, compruebe que no hayan quedado limaduras metálicas o impurezas en el imán.

Prima del montaggio, assicurarsi che non siano rimasti trucioli metallici o altre impurità sur magnete.

M_L Minimum torque for loosening

M_L Par mínimo para desatornillar

M_L Coppia minima per svitare

(b) 0,7 Ncm

Order of assembly - Orden del montaje - Ordine dell'assemblaggio:
Electronic module - Módulo electrónico - Modulo elettronico

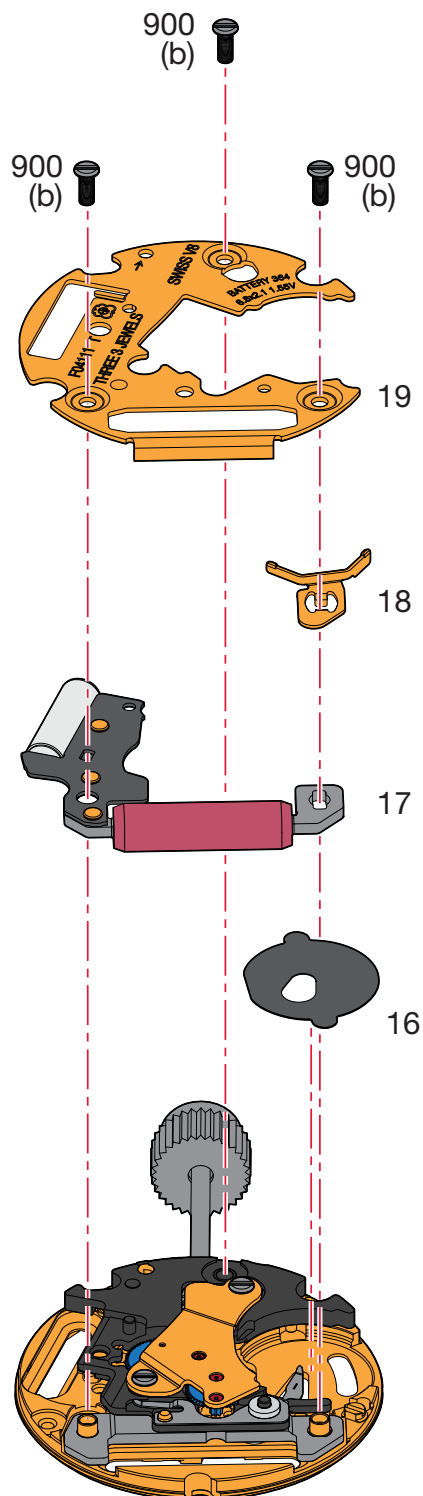

Assembling of the electronic module

(Parts listed in order of assembly)

Montaje del módulo electrónico

(Lista de fornitureas por orden de ensamblado)

Montaggio del modulo elettronico

(Elenco delle forniture in ordine di montaggio)

16	18	900 (3x)
17	19	

M_L Minimum torque for loosening

M_L Par mínimo para desatornillar

M_L Coppia minima per svitare

(b) 0,7 Ncm

Order of assembly - Orden del montaje - Ordine dell'assemblaggio:
 Calendar mechanism - Mecanismo de calendario - Meccanismo del calendario

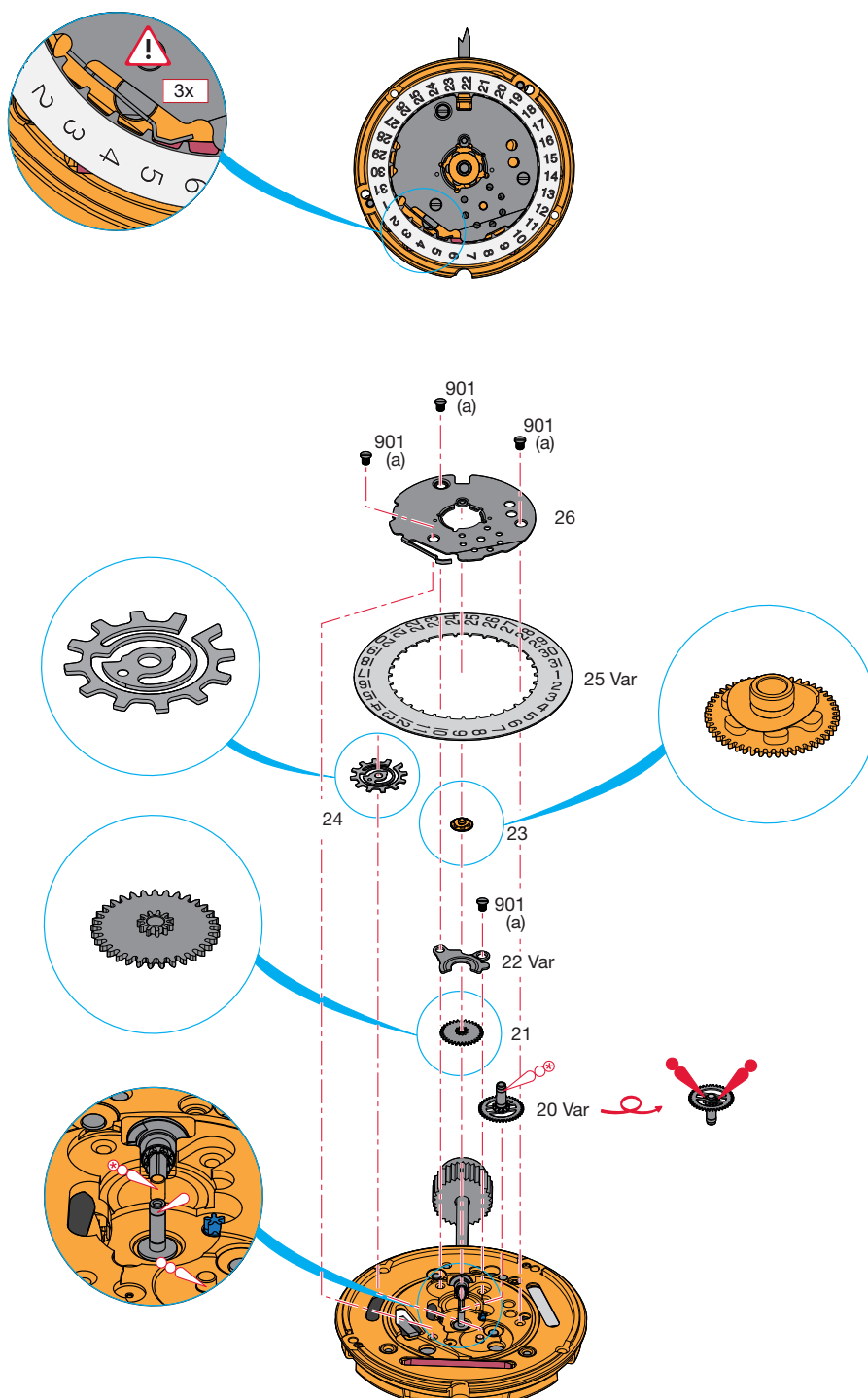

Assembling of the calendar mechanism

(Parts listed in order of assembly)

Montaje del mecanismo de calendario

(Lista de fornitureas por orden de ensamblado)

Montaggio del meccanismo del calendario

(Elenco delle forniture in ordine di montaggio)

20 Var	901 (1x)	25 Var
21	23	26
22 Var	24	901 (3x)

Lubrication - Lubricación - Lubrificazione

Fine oil
Aceite fino
Olio fluido

Moebius 9014
or / ó / o
Moebius 9034



Thick oil or grease
Aceite espeso o grasa
Olio denso o grasso

Moebius HP-1300
or / ó / o
Moebius D5



Very small quantity
Cantidad muy pequeña
Piccolissima quantità

Moebius HP-1300
or / ó / o
Moebius D5



Grease
Grasa
Grasso

Moebius 9501
or / ó / o
Jismaa 124



Grease
Grasa
Grasso

Molykote DX

M_L Minimum torque for loosening**M_L Par mínimo para desatornillar****M_L Coppia minima per svitare**

(a) 0,6 Ncm

	Lubricate part 26. 1. Lubrique la pieza 26. Lubrificare il pezzo 26.
	Rotate part 25 approx 10 teeth with rapide correction. 2. Gire la pieza 25 unos 10 dientes con la corrección rápida. Ruotare il pezzo 25 di circa 10 denti con la correzione rapida.
	Lubricate again part 26. 3. Lubrique de nuevo la pieza 26. Lubrificare di nuovo il pezzo 26.
	Rotate part 25 approx 10 teeth with rapide correction again. 4. Gire de nuevo la pieza 25 unos 10 dientes con la corrección rápida. Ruotare di nuovo il pezzo 25 di circa 10 denti con la correzione rapida.
	Lubricate again part 26. 5. Lubrique de nuevo la pieza 26. Lubrificare di nuovo il pezzo 26.
	Rotate part 25 approx 10 teeth with rapide correction again. 6. Gire de nuevo la pieza 25 unos 10 dientes con la corrección rápida. Ruotare di nuovo il pezzo 25 di circa 10 denti con la correzione rapida.

Order of assembly - Orden del montaje - Ordine dell'assemblaggio:
Battery - Pila - Pila

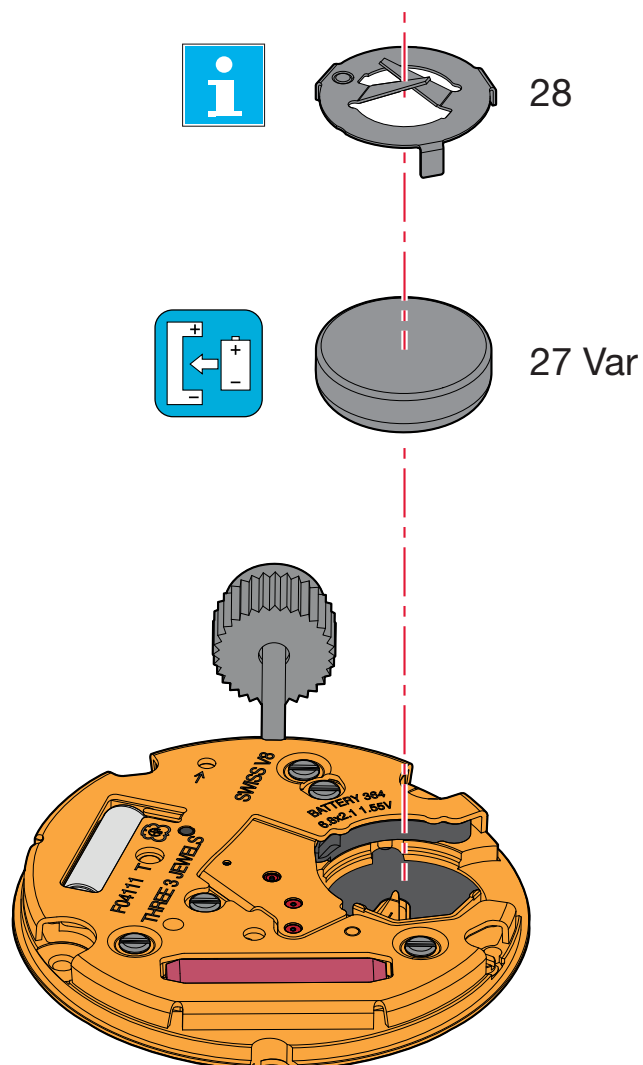

Assembling of the battery

(Parts listed in order of assembly)

Montaje de la pila

(Lista de fornitureas por orden de ensamblado)

Montaggio pila

(Elenco delle forniture in ordine di montaggio)

27 Var

28

M_L Minimum torque for loosening**M_L Par mínimo para desatornillar****M_L Coppia minima per svitare**

(b) 0,7 Ncm

Pos 28:

The limit spring is only necessary when the distance from the battery to the base of the casing is too far.

For further details please go to:

Manufacturing Information

"FRAME FOR CASE"



El muelle de sujeción solo es necesario si la distancia entre la pila y el fondo de la caja es demasiado grande.

Para más información, véase:

Información del fabricante

"ARMAZÓN DE LA CAJA"

La molla distanziatrice è necessaria solo in caso di distanza ampia tra la batteria e il fondo della cassa.

Per dettagli, vedere:

Informazioni del produttore

"STRUTTURA PER CASSA"

Electrical tests - Controles eléctricos - Controlli elettrici

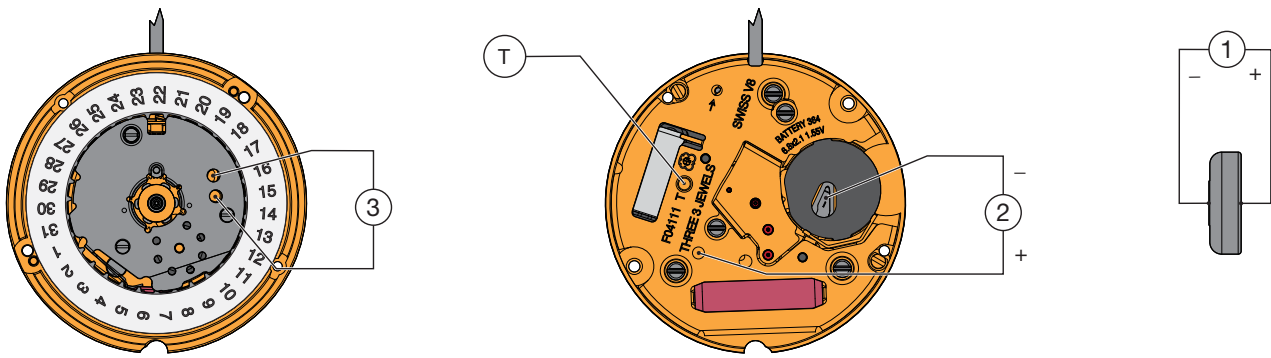

Position Posición Posizione	Setting of apparatus Escala de medición Scala di misura	Measurement Medición Misura	Test Control Controllo	Remarks Notas Osservazioni
1		1,55 V	Battery voltage Tensión de la pila Tensione della pila	
2	2 V	4 steps jump every 4 sec., when feed voltage < 1,30 V. Salto de 4 pasos cada 4 segundos, con tensión de alimentación < 1,30 V. Scatto di 4 passi ogni 4 secondi quando la tensione di alimentazione < 1,30 V.	EOL function. Enf of life test for the battery. Función EOL. Prueba de indicación de fin de vida de la pila. Funzione EOL. Prova dell'indicazione di fine vita della pila.	Measurement without battery, with feed voltage < 1,30 V. E.O.L. function after about 2 min. Medición sin pila, con tensión de alimentación < 1,30 V. E.O.L. funcionamiento después de ~ 2 minutos. Misura senza pila, con tensione di alimentazione < 1,30 V. E.O.L.-funzionamento dopo ~ 2 minuti.
		Connect T point with the – conductor. If the voltage is > 1,46 V, motor driven with 8 steps/s. If the voltage is < 1,30 V, motor driven with 32 steps/s. Conectar el punto T con la pista –. Si la tensión > 1,46 V, mando del motor a 8 pasos/s. Si la tensión < 1,30 V, mando del motor a 32 pasos/s. Mettere in contatto il punto T con la pista –. Se la tensione > 1,46 V, comanda del motore con 8 passi/s. Se la tensione < 1,30 V, comanda del motore con 32 passi/s.	Lower working-voltage limit. Límite inferior de la tensión de funcionamiento. Limite inferiore della tensione di funzionamento.	Measurement without battery, with variable external power supply, starting with 1,55 V, lower tension until movement stops. Medición sin pila, con alimentación exterior variable bajando de 1,55 V hasta que la máquina se detenga. Misura senza pila con alimentazione esterna variabile, scendendo da 1,55 V fino all'arresto del movimento.
			Consumption of movement. Consumo de la máquina. Consumo del movimento.	
	10 µA		Function of stop lever, pos. 3 of handsetting stem. Funcionamiento del interruptor en pos. 3 de la tija de puesta en hora. Funzionamento dell'interruttore in posizione 3 dell'albero di messa all'ora.	Measurement without battery, with external power supply 1,55 V. Medición sin pila, con alimentación exterior 1,55 V. Misura senza pila, con alimentazione esterna di 1,55 V.

Position Posición Posizione	Setting of apparatus Escala de medición Scala di misura	Measurement Medición Misura	Test Control Controllo	Remarks Notas Osservazioni
3	1 V ($R_i \geq 10 \text{ k}\Omega/V$)	Hand of measuring apparatus oscillates in + and - direction. La aguja del multímetro oscila en sentido + y -. La lancette del multímetro oscila nel senso + e -.	Impulses at output of integrated circuit: 1 every second. Impulsos a la salida del circuito integrado: 1 por segundo. Impulsi all'uscita del circuito integrato: 1 per secondo.	Measurement with battery. Medición con una pila. Misura con una pila.
<p><i>The test must be conducted at an ambient temperature of between 20°C and 25°C. Las pruebas deben realizarse a una temperatura ambiente comprendida entre 20°C y 25°C. I test devono essere effettuati a temperatura ambiente compresa tra 20°C e 25°C.</i></p>				

Note:

In order to access the stops of the spool and detect the motor pulse, use two very fine points to contact the two jumper plugs as shown in point 3 of the above diagram.

Observación:

Para acceder a los bornes de la bobina y detectar el impulso motor, es necesario hacer contacto con las dos zonas mediante dos puntas muy finas como se indica en el punto 3 del dibujo presentado arriba.

Osservazione:

Per avere accesso alle bobine magnetiche e individuare l'impulso motore, le due superfici devono essere toccate con due punte finissime, come illustrato al punto 3 nel disegno di sopra.

Fitting the battery

Slide the battery against the contact strip ①. Press the battery firmly into its mounting ②. The contact strip keeps the battery in position.

The tweezers must not be electrically conductive!

Colocación de la pila

Deslice la pila hasta la brida de fijación ①. A continuación, presione la pila hacia dentro de su alojamiento ②. La brida + mantiene la pila en su posición.

Las pinzas no deben ser conductoras de la electricidad!

Posa della pila

Inserire la batteria nelle staffe di contatto ①. E quindi premerla nell'apposito vano ②. La staffa + tiene la batteria in posizione.

La pinzetta non deve condurre elettricità!

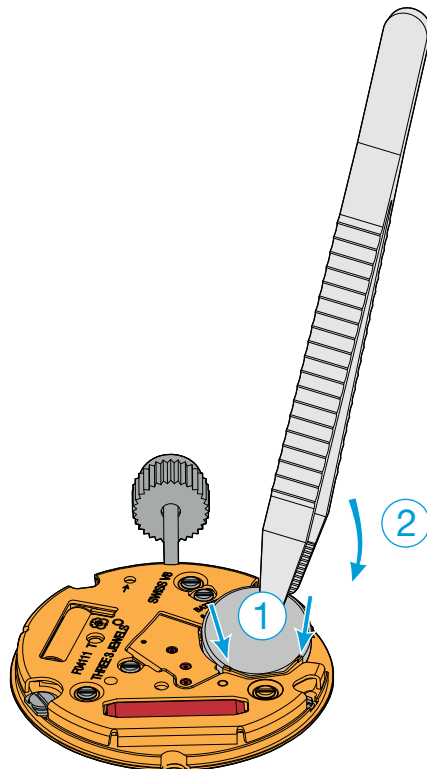

Removing the battery

Insert tweezers ① between module and battery (see drawing) and pry out the battery by gently lifting back ② the contact strip. Remove the battery ③.

The tweezers must not be electrically conductive!

Retiro de la pila

Insertar unas pinzas ① entre el módulo y la pila (véase dibujo) y palanquear la pila apartando cuidadosamente el dedo del cubre-módulo ②. Sacar la pila ③.

Las pinzas no deben ser conductoras de la electricidad!

Ritiro della pila

Far scivolare una pinzetta ① tra il modulo e la pila (vedi disegno) e fare leva sotto quest'ultima allargando leggermente il dito di sostegno verso dietro ②. Ritirare la pila ③.

La pinzetta non deve condurre elettricità!

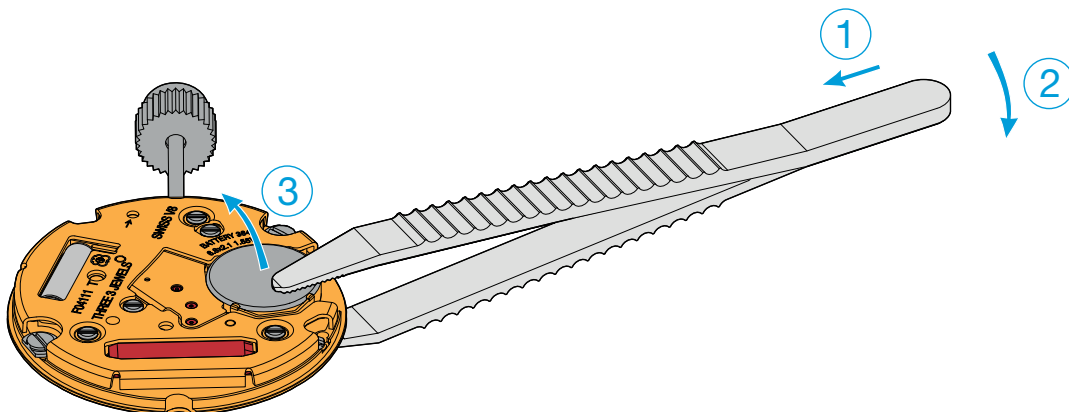

Extracting the stem

The handsetting stem must be pushed back to position 1 (neutral) before pressing on the point lying on the right sider of the setting lever.

Extracción de la tija de puesta en hora

Antes de pulsar el punto a la derecha del tirete, es obligatorio empujar la tija de puesta en hora en posición 1 (neutral).

Estrazione dell'albero di messa all'ora

Prima di premere il punto a destra del tireto, è obbligatorio premere l'albero di messa all'ora in posizione 1 (neutra).

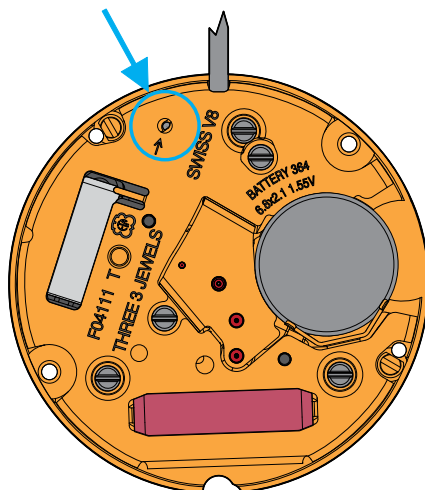



For information regarding hand fitting heights see:

Manufacturing Information

Drawing:
AIGUILLAGES
ZEIGERWERKHÖHEN
HAND FITTING HEIGHTS



Para obtener información sobre las alturas de la minutería, consulte:

Información de la producción

Plan:
AIGUILLAGES
ZEIGERWERKHÖHEN
HAND FITTING HEIGHTS



Per informazioni concernenti l'aggiustamento lancette, consultare:

Informazione di produzione

Disegno:
AIGUILLAGES
ZEIGERWERKHÖHEN
HAND FITTING HEIGHTS

This page has deliberately been left blank in case of A3 format printing.

Esta página se han dejado en blanco a propósito en caso de imprimirla en formato A3.

Questa pagina è lasciata intenzionalmente bianca in caso di stampa formato A3.

This page has deliberately been left blank in case of A3 format printing.

Esta página se han dejado en blanco a propósito en caso de imprimirla en formato A3.

Questa pagina è lasciata intenzionalmente bianca in caso di stampa formato A3.

This page has deliberately been left blank in case of A3 format printing.

Esta página se han dejado en blanco a propósito en caso de imprimirla en formato A3.

Questa pagina è lasciata intenzionalmente bianca in caso di stampa formato A3.

Modifications compared with previous document versions**Modificaciones comparadas con las versiones anteriores del documento****Modifiche comparate con le versioni precedenti del documento**

Version Versión Versione	Date Fecha Data	Modification	Modificación	Modifica	Page Página Pagina
17	29.06.2016	Materials pos. 13	Fornituras pos. 13	Forniture pos. 13	4-5
16	17.09.2015	Chapter electrical tests	Sección controles eléctricos	Sezione controlli elettrici	16
15	05.08.2014	New drawings	Nuevos planos	Nuovi disegni	20-21
14	01.07.2014	New drawing	Nuevo plan	Nuovo disegno	20
		Adaptation variant and GTIN number	Adaptación variante y número GTIN	Adattamento variante e numero GTIN	3-6, 10
13	10.01.2014	Text correction	Corrección texto	Correzione testo	13
12	25.09.2013	Order of spare parts correction	Corrección del orden de piezas	Correzioni ordine delle forniture	3
		New illustrations	Nuevas ilustraciones	Nuove illustrazioni	1, 4-14
		New chapter	Nuevo capítulo	Nuovo capitolo	18-19
11	03.04.2013	Addition lubrication on drawing	Lubrificación adicional según dibujo	Aggiunta lubrificazione come sul disegno	10-11
		New drawings	Nuevos planos	Nuovi disegni	14-15
10	14.01.2013	New drawing	Nuevo plan	Nuovo disegno	14
09	19.06.2012	New drawing	Nuevo plan	Nuovo disegno	14
08	28.01.2011	Position 2 corrections	Correcciones de posición 2	Correzione posizione 2	12
		Correction EOL: position 2	Corrección EOL: posición 2	Correzione EOL: posizione 2	12
07	30.11.2010	Modification impulses	Modificación impulsos	Modifica impulsi	13
06	04.11.2009	Addition number GTIN	Adición número GTIN	Aggiunta dei numeri GTIN	2
05	08.04.2009	Addition bridle - and washer	Brida - y washer adicional	Aggiungere brida - e rondella	2-3
		New drawing (Part No 8)	Nuevo plano (pieza No 8)	Nuovo disegno (pezzo No 8)	3
		New illustrations	Nuevas ilustraciones	Nuove illustrazioni	4-6

All modifications reserved.

Salvo modificación.

Con riserva di ogni eventuale modifica.

This document can be found on the Customer Service Portal (CSP):www.eta.ch

- Customer Service
- Customer Service Portal
- Technical Documents

Este documento se encuentran en el Customer Service Portal (CSP):www.eta.ch

- Customer Service
- Customer Service Portal
- Technical Documents

Il presente documento si trovano sul Customer Service Portal (CSP):www.eta.ch

- Customer Service
- Customer Service Portal
- Technical Documents



ETA^{SA}
MANUFACTURE HORLOGÈRE SUISSE
DEPUIS 1793

SC MARKETING & COMMUNICATION

Bahnhofstrasse 9
2540 Grenchen
Switzerland

Phone +41 (0)32 655 71 11
Fax +41 (0)32 655 71 74

contact@eta.ch
www.eta.ch