

A

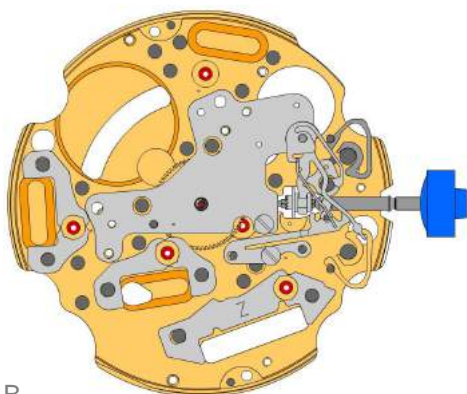
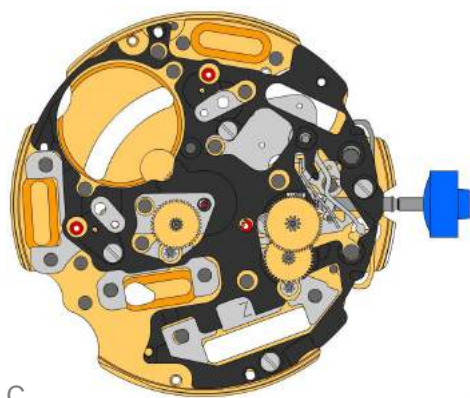

B

2000.574.G 1.		Platine
3305.282.CO 2.		Chaussée avec entraîneur (Aig.2)
3301.244 3.		Roue des heures (cpt 24h)
2030.024.CO 4.		Pont de centre Pont de centre tenue par 1 vis 4000.250.
4000.250 5.		Vis
3001.055.FI 6.		Pignon coulant
3000.177.CO 7.		Tige de mise à l'heure
3017.049 8.		Tirette
3905.049 9.		Sautoir de tirette (3 positions) Sautoir de tirette tenue par 1 vis 4000.250.
4000.250 10.		Vis
3015.081 11.		Bascule (3 positions)
3905.067 12.		Ressort de bascule Mise en tension du ressort.
3406.030 13.		Sautoir de poussoir B Fixer le sautoir de poussoir gris entre les deux piliers plus loin.
3406.038 14.		Sautoir de poussoir A Fixer le sautoir de poussoir jaune entre les deux piliers plus proche.
3622.040 15.		Stator Marquage [Z] sur le stator.
3622.039 16.		Stator (cpt 6h, 9h, chrono)
3622.039 17.		Stator (cpt 6h, 9h, chrono)

C

3603.079
18.  **Potence plastique**
Potence plastique tenue par 4 vis 4000.250.

4000.250
19.  **Vis**

3715.094.RK
20.  **Rotor**

3715.094.RK
21.  **Rotor**

3147.046.CO
22.  **Roue intermédiaire**

3136.142.CO
23.  **Roue de seconde (longue)**

3147.047.CO
24.  **Roue intermédiaire (chrono)**

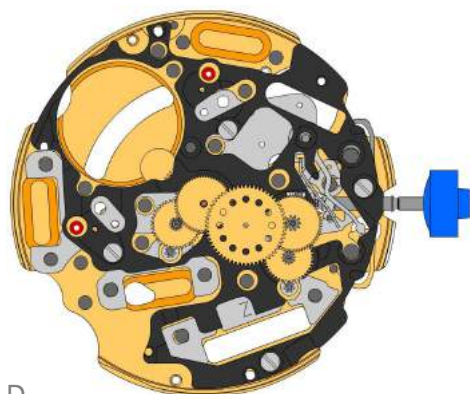
D

3136.144.CO
25.  **Roue de chronographe (Aig.2)**

3122.056.CO
26.  **Roue moyenne**

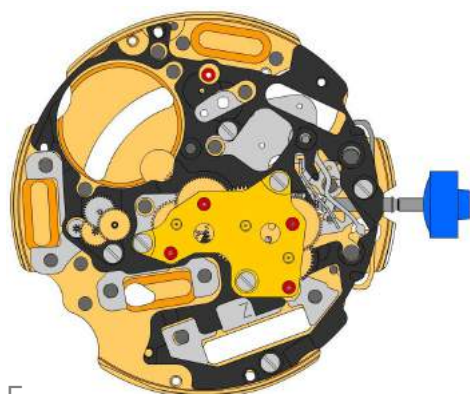

E

2020.148.G
27.  **Pont de rouage**
Pont de rouage tenue par 3 vis 4000.250.

4000.250
28.  **Vis**









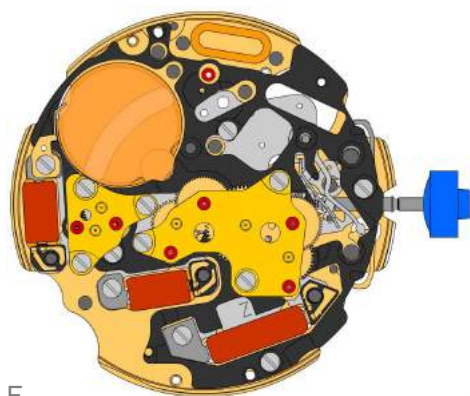
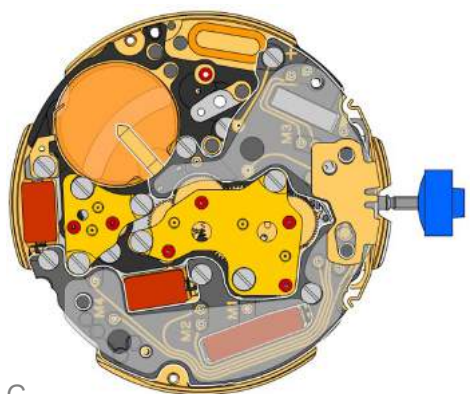
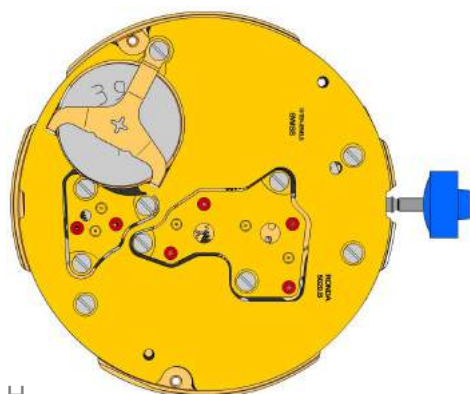







3715.095.RK
29.  **Rotor**

3147.048.CO
30.  **Roue intermédiaire (cpt)**









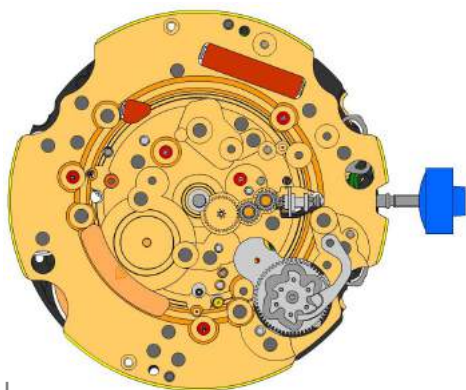
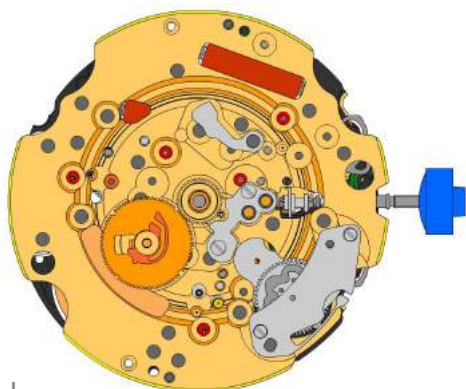





3007.056.CO
31.  **Roue de minuterie (cpt 24h)**

3402.008.CO
32.  **Roue compteuse de minutes (24h)**

F

G

H

2020.149.G 33.		Pont de rouage compteur Pont de rouage compteur tenue par 3 vis 4000.250.
4000.250 34.		Vis
3621.053.RK 35.		Bobine Attention: Prendre la bobine uniquement par le noyau de bobine gris. Bobine tenue par 1 vis 4000.250.
3621.054.RK 36.		Bobine (cpt 9h, chrono) Attention: Prendre la bobine uniquement par le noyau de bobine gris. Bobine tenue par 1 vis 4000.250.
3621.054.RK 37.		Bobine (cpt 9h, chrono) Attention: Prendre la bobine uniquement par le noyau de bobine gris. Bobine tenue par 1 vis 4000.250.
3601.118 38.		Bride contact Bride contact tenue par 1 vis 4000.250.
4000.250 39.		Vis
3503.054 40.		Tube
3603.034 41.		Isolateur pile
3612.144.5020 42.		Module électronique Module électronique tenue par 5 vis 4000.248. Les mesures électroniques peuvent être réaliser maintenant.
4000.248 43.		Vis
3603.069 44.		Isolateur de circuit
3601.107.G 45.		Ressort contact pousoirs
2130.138.G.M01.5020B 46.		Couvre-module électronique Couvre-module électronique tenue par 3 vis 4000.250.
3600.010.HGF 47.		Pile 395
3601.109.G 48.		Bride + Bride tenue par 1 vis 4000.250.
4000.250 49.		Vis

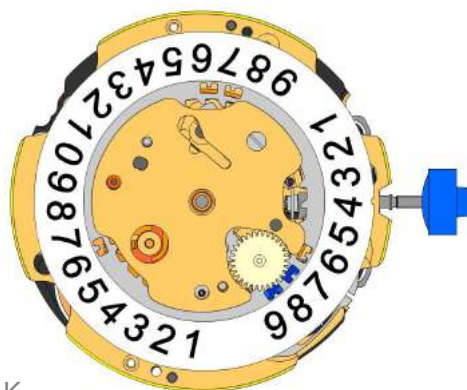
I

J



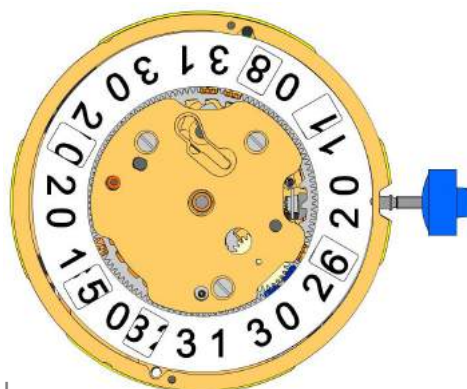

2000.574.G 50.		Platine
3004.164 51.		Renvoi
3004.164 52.		Renvoi
3007.054.CO 53.		Roue de minuterie
2130.143 54.		Pont du rouage de minuterie Pont du rouage de minuterie tenue par 2 vis 4000.305.
4000.305 55.		Vis
3004.227 56.		Roue entraîneuse des dizaines Positionnement de la dent courte de la roue entraîneuse des dizaines en direction le centre du mouvement.
3500.075 57.		Sautoir des dizaines
2130.142 58.		Plaque de maintien du sautoir des dizaines Plaque maintien sautoir des dizaines tenue par 2 vis 4000.306. Mise en tension du ressort en mettant le bras derrière du sautoir des dizaines.
4010.306 59.		Vis
3301.242 60.		Roue des heures (Aig.2)
3315.016 61.		Clinquant
3004.224.CO 62.		Roue entraîneuse de quantième
3500.049 63.		Sautoir de quantième



K

3504.214.AD.1.A 64.		Indicateur des unités (standard) Marquage de l'indicateur à 3 heures.
3147.054 65.		Roue intermédiaire dizaines
2130.141 66.		Plaque de maintien de l'indicateur de quantième Plaque maintien indicateur de quantième tenue par 1 vis 4000.250.
3905.070 67.		Ressort sautoir de quantième Insertion du ressort sautoir de quantième dans l'ouverture.

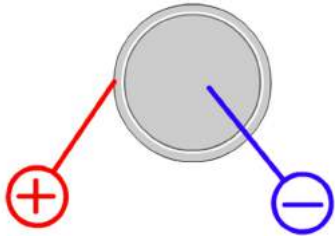

L

3504.215.AD.1.A 68.		Indicateur des dizaines (standard) Marquage de l'indicateur à 3 heures.
2130.140.G 69.		Plaque de maintien du mécanisme de quantième Plaque maintien mécanisme de quantième tenue par 2 vis 4000.250.
4000.250 70.		Vis
3506.072.G 71.		Support de cadran

8200 72.		Moebius 8200
9014 73.		Moebius 9014
124 74.		Jismaa 124
9020 75.		Moebius 9020

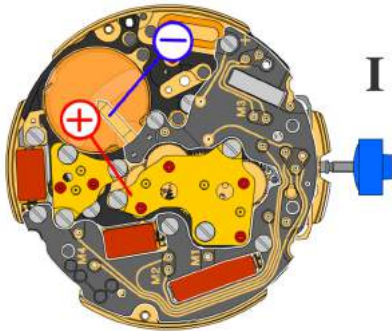

Pile	395
Tension	1.55 V



Tige de mise à l'heure en position I, calendrier hors engrenage, intervalle de mesure 60 s pour la marche et la consommation:

Consommation typique	1.32 μA
Consommation maximale	1.65 μA
Marche	-10s/M. .. +20s/M.
Limite inférieure de la tension de fonctionnement	1.20 V

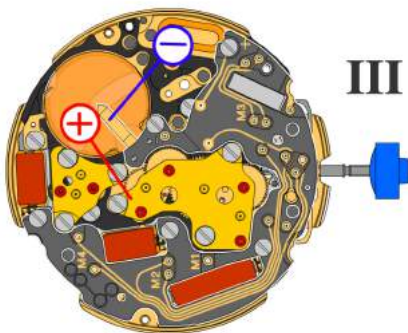

Tige de mise à l'heure en position III, intervalle de mesure 60 s:

Typical consumption	0.10 μA
Maximal consumption	0.30 μA

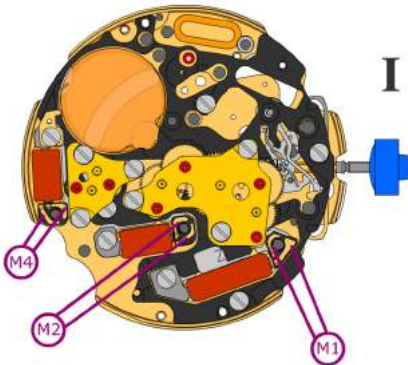

Résistance de la bobine M1 **1.90 kΩ .. 2.10 kΩ**

Résistance de la bobine M2 **1.68 kΩ .. 1.88 kΩ**

Résistance de la bobine M4 **1.68 kΩ .. 1.88 kΩ**

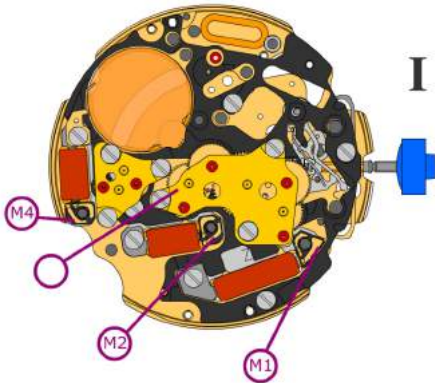

Isolation de la bobine M1/M2/M4 **∞ kΩ**

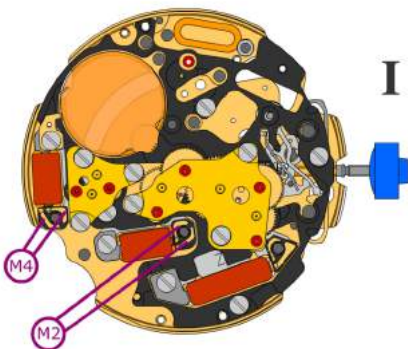

Générateur d'impulsion
(4.9 ms, 8 Hz):

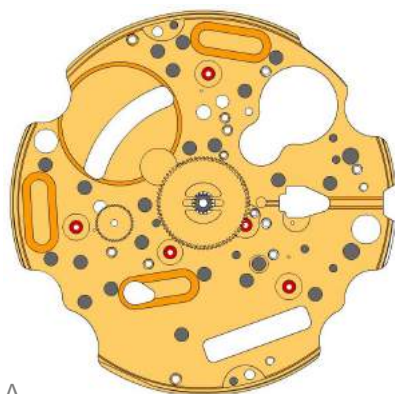

Limite inférieure de la tension de
fonctionnement M2/M4 **1.20 V**

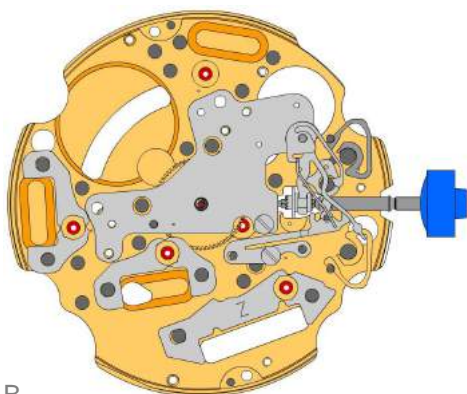

A



B

2000.574.G 1.		Main plate
3305.282.CO 2.		Cannon pinion with driver (Aig.2)
3301.244 3.		Hour wheel (counter 24h)
2030.024.CO 4.		Centre bridge Centre bridge held by 1 screw 4000.250.
4000.250 5.		Screw
3001.055.FI 6.		Sliding pinion
3000.177.CO 7.		Setting stem
3017.049 8.		Setting lever
3905.049 9.		Setting lever jumper (3 positions) Setting lever jumper held by 1 screw 4000.250.
4000.250 10.		Screw
3015.081 11.		Yoke (3 positions)
3905.067 12.		Yoke spring Tensioning the spring arm.
3406.030 13.		Pusher jumper B Put the grey jumper between the two posts on the further side.
3406.038 14.		Pusher jumper A Put the yellow jumper between the two posts on the closer side.
3622.040 15.		Stator Mark [Z] on stator.
3622.039 16.		Stator (counter 6h, 9h, chrono)
3622.039 17.		Stator (counter 6h, 9h, chrono)

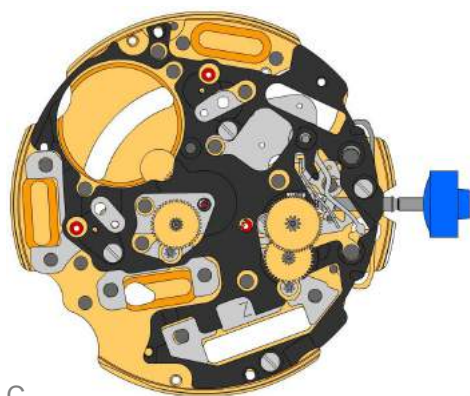
C

3603.079
18.  **Plastic bracket**
Plastic bracket held by 4 screws 4000.250.

4000.250
19.  **Screw**

3715.094.RK
20.  **Rotor**

3715.094.RK
21.  **Rotor**

3147.046.CO
22.  **Intermediate wheel**

3136.142.CO
23.  **Second wheel (long)**

3147.047.CO
24.  **Intermediate wheel (chrono)**

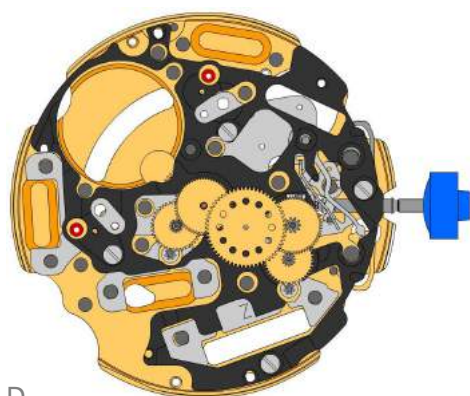
D

3136.144.CO
25.  **Chronograph wheel (Aig.2)**

3122.056.CO
26.  **Third wheel**

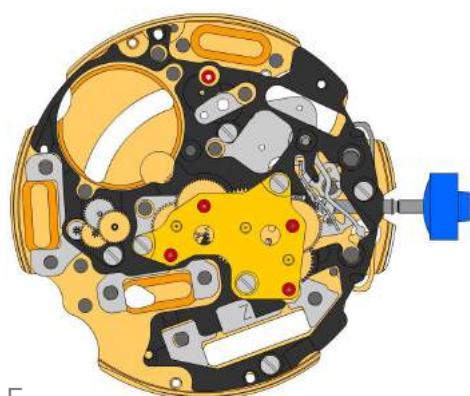
E

2020.148.G
27.  **Train wheel bridge**
Train wheel bridge held by 3 screws 4000.250.

4000.250
28.  **Screw**









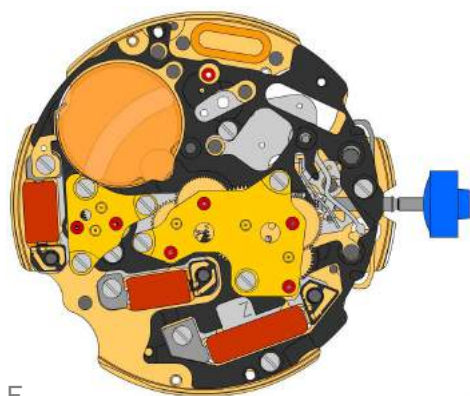
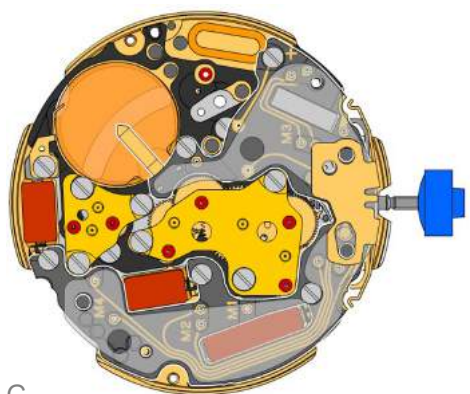
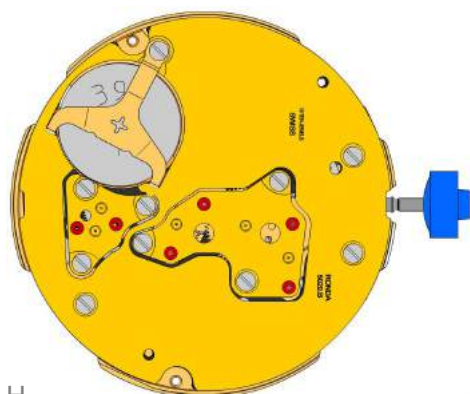







3715.095.RK
29.  **Rotor**

3147.048.CO
30.  **Intermediate wheel (counter)**









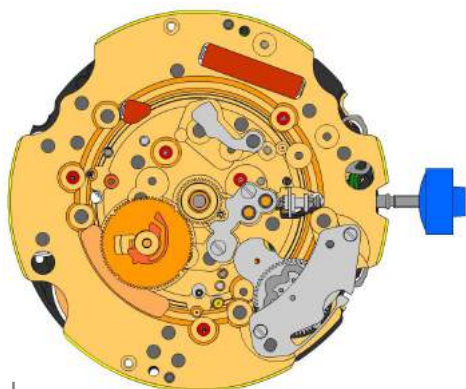
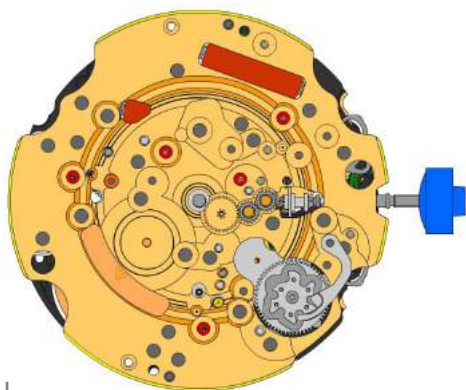





3007.056.CO
31.  **Minute wheel (counter 24h)**

3402.008.CO
32.  **Minute counting wheel (24h)**

F

G

H

2020.149.G 33.		Counter train wheel bridge Counter train wheel bridge held by 3 screws 4000.250.
4000.250 34.		Screw
3621.053.RK 35.		Coil Attention: Please hold the coil only on the grey coil core. Coil held by 1 screw 4000.250.
3621.054.RK 36.		Coil (counter 9h, chrono) Attention: Please hold the coil only on the grey coil core. Coil held by 1 screw 4000.250.
3621.054.RK 37.		Coil (counter 9h, chrono) Attention: Please hold the coil only on the grey coil core. Coil held by 1 screw 4000.250.
3601.118 38.		Contact strip Contact strip held by 1 screw 4000.250.
4000.250 39.		Screw
3603.034 40.		Battery insulator
3503.054 41.		Tube
3612.144.5020 42.		Electronic module Electronic module tenue par 5 vis 4000.248. Electronic measurements may be realised now.
4000.248 43.		Screw
3603.069 44.		Circuit insulator
3601.107.G 45.		Pusher contact spring
2130.138.G.M01.5020B 46.		Electronic module cover Electronic module cover held by 3 screws 4000.250.
3600.010.HGF 47.		Battery 395
3601.109.G 48.		Bridle + Bridle held by 1 screw 4000.250.
4000.250 49.		Screw

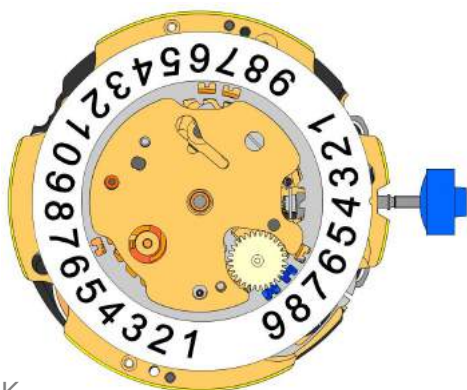





2000.574.G 50.		Main plate
3004.164 51.		Setting wheel
3004.164 52.		Setting wheel
3007.054.CO 53.		Minute wheel
2130.143 54.		Minute train bridge Minute train bridge held by 1 screw 4000.305.
4000.305 55.		Screw
3004.227 56.		Tens indicator driving wheel The short tooth of the tens indicator driving wheel must point to the center of the movement.
3500.075 57.		Tens jumper
2130.142 58.		Tens jumper maintaining plate
4010.306 59.		Screw
3301.242 60.		Hour wheel (Fig.2)
3315.016 61.		Friction spring
3004.224.CO 62.		Date indicator driving wheel
3500.049 63.		Date jumper

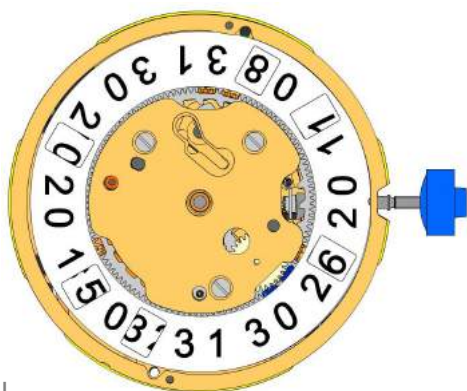









K



L

3504.214.AD.1.A 64.		Units indicator (standard) Nick of the indicator at 3 o'clock.
3147.054 65.		Tens intermediate wheel
2130.141 66.		Date indicator maintaining plate Nick of the indicator at 3 o'clock.
3905.070 67.		Date jumper spring Insert the date jumper spring in the provided opening.

3504.215.AD.1.A 68.		Tens indicator (standard) Nick of the indicator at 3 o'clock.
2130.140.G 69.		Date mechanism maintaining plate Date mechanism maintaining plate held by 2 screws 4000.250.
4000.250 70.		Screw
3506.072.G 71.		Dial support

8200 72.		Moebius 8200
9014 73.		Moebius 9014
124 74.		Jismaa 124
9020 75.		Moebius 9020

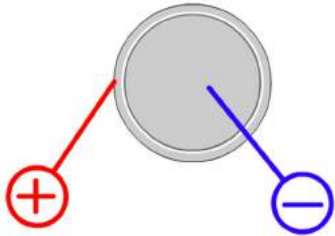

Battery	395
Voltage	1.55 V

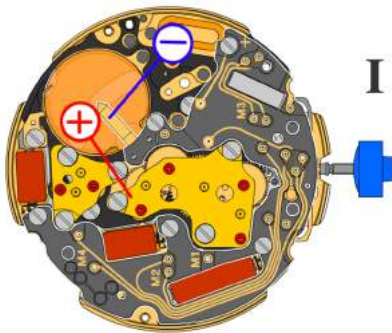

*Setting stem in position I, calendar not in gear,
60 s measuring interval for rate and consumption:*

Typical consumption	1.32 μA
Maximal consumption	1.65 μA
Rate	-10s/M. .. +20s/M.
Lower working voltage limit	1.20 V

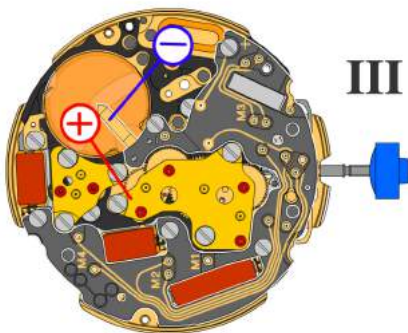

Setting stem in position III, 60 s measuring interval:

Typical consumption	0.10 μA
Maximal consumption	0.30 μA

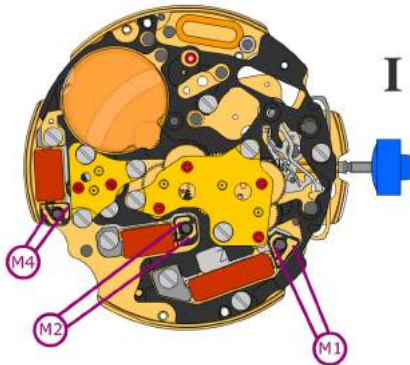

Coil resistance M1 **1.90 k Ω .. 2.10 k Ω**

Coil resistance M2 **1.68 k Ω .. 1.88 k Ω**

Coil resistance M4 **1.68 k Ω .. 1.88 k Ω**

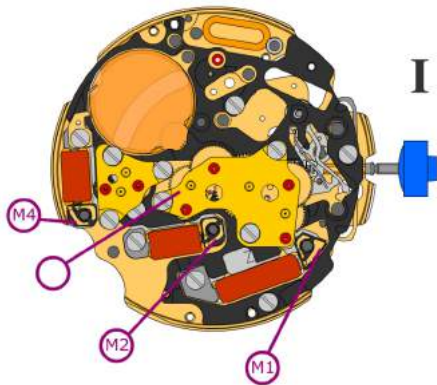

Coil isolation M1/M2/M4 **∞ k Ω**

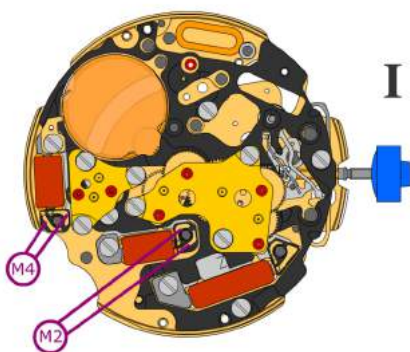

Signal generator (4.9 ms, 8 Hz):

Lower working voltage limit M2/M4 **1.20 V**

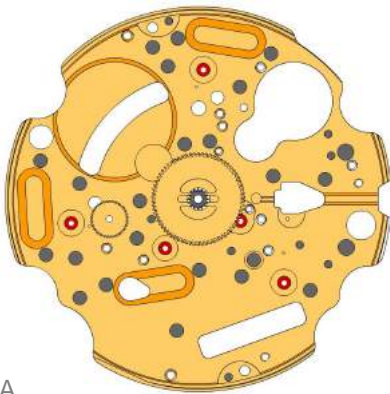

A

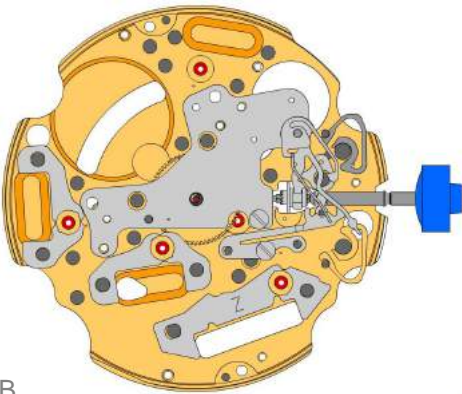

B

2000.574.G 1.		Werkplatte
3305.282.CO 2.		Minutenrohr mit Mitnehmer (Aig.2)
3301.244 3.		Stundenrad (Zähler 24h)
2030.024.CO 4.		Zentrumbrücke Zentrumbrücke gehalten durch 1 Schraube 4000.250.
4000.250 5.		Schraube
3001.055.FI 6.		Kupplungstrieb
3000.177.CO 7.		Stellwelle
3017.049 8.		Winkelhebel
3905.049 9.		Winkelhebelraste (3 Positionen) Winkelhebelraste gehalten durch 1 Schraube 4000.250.
4000.250 10.		Schraube
3015.081 11.		Wippe (3 Positionen)
3905.067 12.		Wippenfeder Den Federarm spannen.
3406.030 13.		Drückerraste B Graue Drückerraste zwischen den beiden Säulen auf der entfernteren Seite platzieren.
3406.038 14.		Drückerraste A Gelbe Drückerraste zwischen den beiden Säulen auf der näheren Seite platzieren.
3622.040 15.		Stator Markierung [Z] auf Stator.
3622.039 16.		Stator (Zähler 6h, 9h, Chrono)
3622.039 17.		Stator (Zähler 6h, 9h, Chrono)

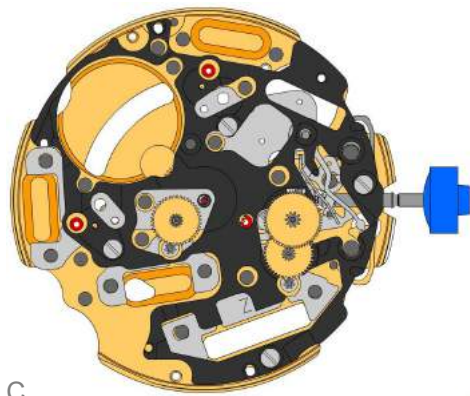

C

3603.079
18.  Kunststoffhalterung
Kunststoffhalterung gehalten durch 4 Schrauben 4000.250.

4000.250
19.  Schraube

3715.094.RK
20.  Rotor

3715.094.RK
21.  Rotor

3147.046.CO
22.  Zwischenrad

3136.142.CO
23.  Sekundenrad (lang)

3147.047.CO
24.  Zwischenrad (Chrono)

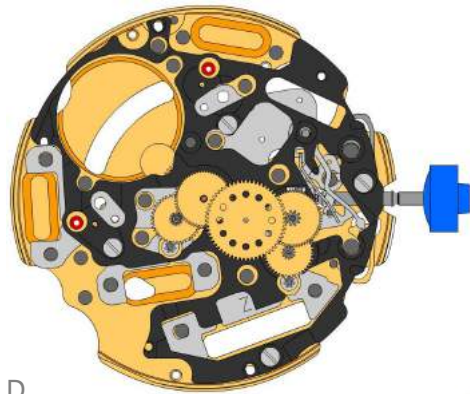

D

3136.144.CO
25.  Chrono-Zentrumrad (Aig.2)

3122.056.CO
26.  Kleinbodenrad

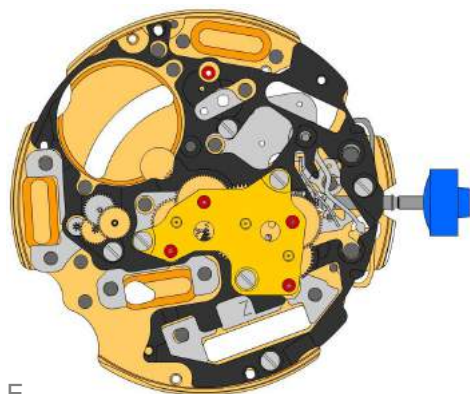

E

2020.148.G
27.  Räderwerkbrücke
Räderwerkbrücke gehalten durch 3 Schrauben 4000.250.

4000.250
28.  Schraube

3715.095.RK
29.  Rotor

3147.048.CO
30.  Zwischenrad (Zähler)

3007.056.CO
31.  Wechselrad (Zähler 24h)

3402.008.CO
32.  Minutenzählrad (24h)

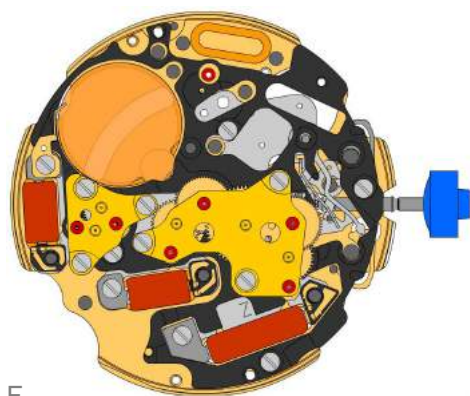



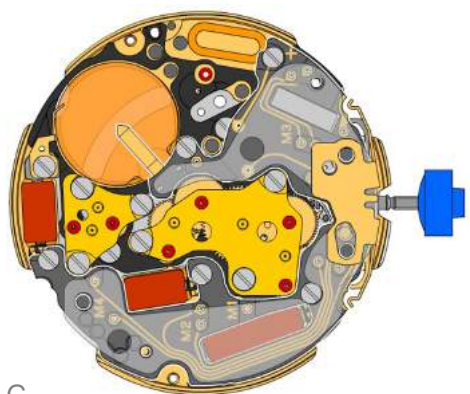



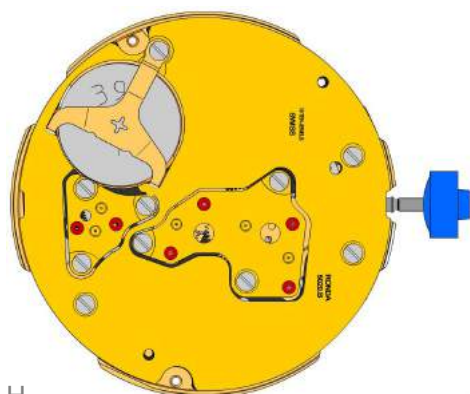





F



G



H

2020.149.G 33.		Zähler-Räderwerkbrücke Zähler-Räderwerkbrücke gehalten durch 3 Schrauben 4000.250.
4000.250 34.		Schraube
3621.053.RK 35.		Spule Achtung: Spule nur am grauen Spulenkern halten. Spule gehalten durch 1 Schraube 4000.250.
3621.054.RK 36.		Spule (Zähler 9h, Chrono) Achtung: Spule nur am grauen Spulenkern halten. Spule gehalten durch 1 Schraube 4000.250.
3621.054.RK 37.		Spule (Zähler 9h, Chrono) Achtung: Spule nur am grauen Spulenkern halten. Spule gehalten durch 1 Schraube 4000.250.
3601.118 38.		Kontaktbügel Kontaktbügel gehalten durch 1 Schraube 4000.250.
4000.250 39.		Schraube
3603.034 40.		Isolation für Batterie
3503.054 41.		Lagerrohr
3612.144.5020 42.		Elektronikmodul Elektronikmodul gehalten durch 5 Schrauben 4000.248. Elektronische Messungen können nun vorgenommen werden.
4000.248 43.		Schraube
3603.069 44.		Isolation für Schaltung
3601.107.G 45.		Drückerkontaktfeder
2130.138.G.M01.5020B 46.		Deckplatte für Elektronikmodul Deckplatte für Elektronikmodul gehalten durch 3 Schrauben 4000.250.
3600.010.HGF 47.		Batterie 395
3601.109.G 48.		Bügel + Bügel gehalten durch 1 Schraube 4000.250.
4000.250 49.		Schraube

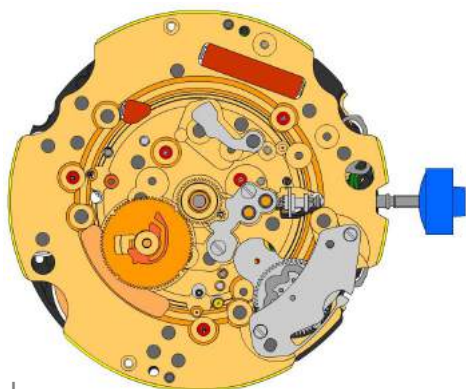
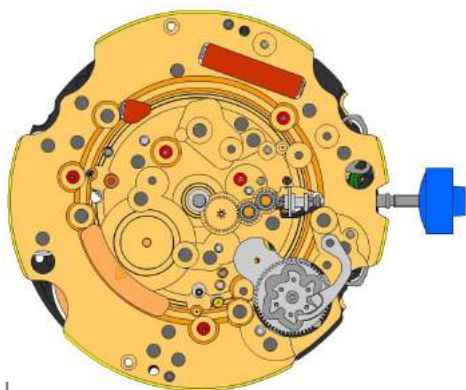

2000.574.G 50.		Werkplatte
3004.164 51.		Zeigerstellrad
3004.164 52.		Zeigerstellrad
3007.054.CO 53.		Wechselrad
2130.143 54.		Wechselradbrücke Wechselradbrücke gehalten durch 2 Schrauben 4000.305.
4000.305 55.		Schraube
3004.227 56.		Zehnermitnehmerrad Kurzer Zahn des Zehnermitnehmerrades in Richtung Werkszentrum positionieren.
3500.075 57.		Zehnerraste
2130.142 58.		Halteplatte für Zehnerraste Den Federarm spannen. Halteplatte für Zehnerraste gehalten durch 2 Schrauben 4000.306.
4010.306 59.		Schraube
3301.242 60.		Stundenrad (Aig.2)
3315.016 61.		Frikionsfeder
3004.224.CO 62.		Datumanzeiger-Mitnehmerrad
3500.049 63.		Datumraste

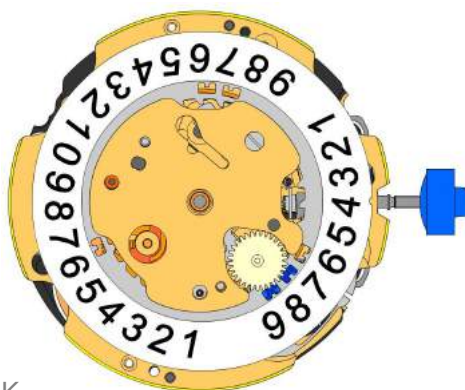



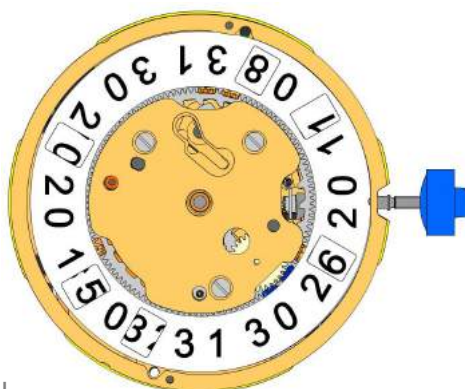

K

3504.214.AD.1.A 64.		Einer Anzeiger (Standard) Einbuchtung im Disc bei 3 Uhr.
3147.054 65.		Zehnerzwischenrad
2130.141 66.		Halteplatte für Datumanzeige Halteplatte für Datumanzeige gehalten durch 1 Schraube 4000.250.
3905.070 67.		Feder für Datumraste Feder für Datumsraste in die Öffnung einfügen.



L

3504.215.AD.1.A 68.		Zehner Anzeiger (Standard) Einbuchtung im Disc bei 3 Uhr.
2130.140.G 69.		Halteplatte für Datum-Mechanismus Halteplatte für Datum-Mechanismus gehalten durch 2 Schrauben 4000.250.
4000.250 70.		Schraube
3506.072.G 71.		Träger für Zifferblatt

8200 72.		Moebius 8200
9014 73.		Moebius 9014
124 74.		Jismaa 124
9020 75.		Moebius 9020

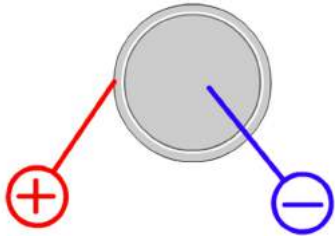

Batterie	395
Spannung	1.55 V

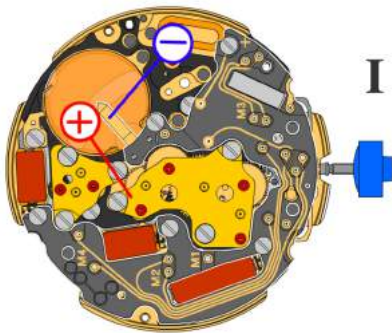

*Stellwelle in Position I, Kalender nicht im Eingriff,
60 s Messintervall für Gang und Verbrauch:*

Typischer Verbrauch	1.32 μA
Maximaler Verbrauch	1.65 μA
Gang	-10s/M. .. +20s/M.
Untere Funktionsspannungsgrenze	1.20 V

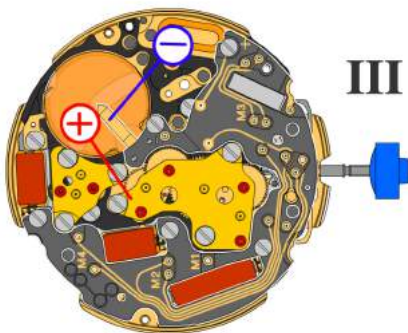

Stellwelle in Position III, 60 s Messintervall:

Typischer Verbrauch	0.10 μA
Maximaler Verbrauch	0.30 μA

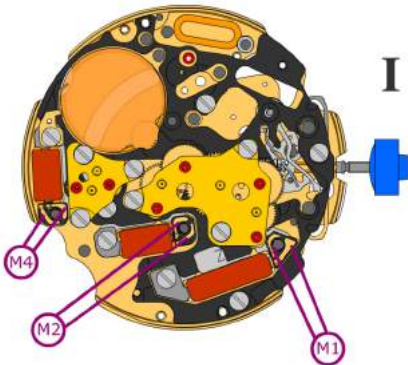

Spulenwiderstand M1 **1.90 k Ω .. 2.10 k Ω**

Spulenwiderstand M2 **1.68 k Ω .. 1.88 k Ω**

Spulenwiderstand M4 **1.68 k Ω .. 1.88 k Ω**

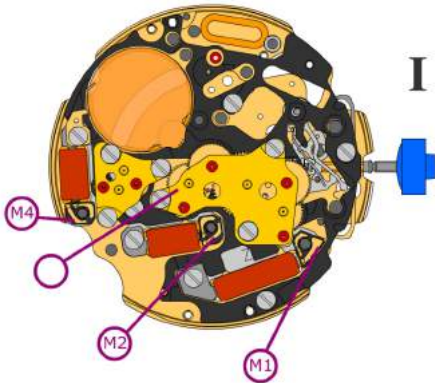

Spulenisolation M1/M2/M4 **∞ k Ω**

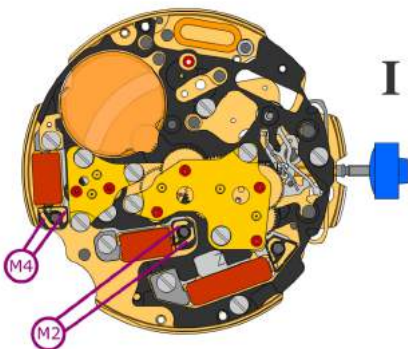

Pulsgenerator (4.9 ms, 8 Hz):

Untere Funktionsspannungsgrenze M2/M4 **1.20 V**