

Micro-forets SPIREC en HSS-E, acier rapide.



Préciser le Ø lors de votre commande.

Exemples :

MSA22.630-0.05 pour Ø 0.05 mm

MSA22.630-1.50 pour Ø 1.50 mm

MSA22.630-2.00 pour Ø 2.00 mm

MSA	Longueur	Ø tige	Ø	Progression	Kg
22.630-0.05	25 mm	1.00 mm	0.05 mm	0.01 mm	0.001
...
22.630-0.79	25 mm	1.00 mm	0.79 mm	0.01 mm	0.001
22.630-0.80	25 mm	1.50 mm	0.80 mm	0.01 mm	0.001
...
22.630-1.00	25 mm	1.50 mm	1.00 mm	0.01 mm	0.001
22.630-1.05	25 mm	1.50 mm	1.05 mm	0.05 mm	0.001
...
22.630-1.45	25 mm	1.50 mm	1.45 mm	0.05 mm	0.001
=====					
22.630-1.50	38 mm	2.00 mm	1.50 mm	-	0.001
22.630-1.55	38 mm	2.00 mm	1.55 mm	-	0.001
22.630-1.58	38 mm	2.00 mm	1.587 mm	-	0.001
22.630-1.60	38 mm	2.00 mm	1.60 mm	0.05 mm	0.001
...
22.630-1.95	38 mm	2.00 mm	1.95 mm	0.05 mm	0.001
22.630-1.98	38 mm	2.00 mm	1.984 mm	-	0.001
=====					
22.630-2.00	43 mm	2.50 mm	2.00 mm	0.05 mm	0.001
...
22.630-2.35	43 mm	2.50 mm	2.35 mm	0.05 mm	0.001
22.630-2.38	43 mm	2.50 mm	2.384 mm	-	0.001
22.630-2.40	43 mm	2.50 mm	2.40 mm	-	0.001
22.630-2.45	43 mm	2.50 mm	2.45 mm	-	0.001
=====					
22.630-2.50	46 mm	3.00 mm	2.50 mm	0.05 mm	0.001
...
22.630-2.75	46 mm	3.00 mm	2.75 mm	0.05 mm	0.001
22.630-2.77	46 mm	3.00 mm	2.778 mm	-	0.001
22.630-2.80	46 mm	3.00 mm	2.80 mm	0.05 mm	0.001
...
22.630-3.00	46 mm	3.00 mm	3.00 mm	0.05 mm	0.001
22.630-3.17	46 mm	3.00 mm	3.175 mm	-	0.001

Micro-forets TITEX en HSS, standard pour utilisation universelle.



Préciser le Ø lors de votre commande.

Exemples :

MSA22.660-020 pour Ø 0.20 mm

MSA22.660-205 pour Ø 2.05 mm

MSA22.660-1000 pour Ø 10.00 mm

MSA	Ø	Progression	Kg
22.660-020	0.20 mm	0.01 mm	0.001
...
22.660-200	2.00 mm	0.01 mm	0.001
=====			
22.660-205	2.05 mm	0.05 mm	0.001
...
22.660-995	9.95 mm	0.05 mm	0.001
=====			
22.660-1000	10.00 mm	0.10 mm	0.001
...
22.660-1690	16.90 mm	0.10 mm	0.001

Micro-forets YAMAMOTO en HSS.



Préciser le Ø lors de votre commande.

Exemples :

MSA22.670-010 pour Ø 0.10 mm

MSA22.670-076 pour Ø 0.76 mm

MSA22.670-135 pour Ø 1.35 mm

MSA	Ø tige	Ø	Progression	Kg
22.670-010	1.00 mm	0.10 mm	0.01 mm	0.001
...
22.670-075	1.00 mm	0.75 mm	0.01 mm	0.001
=====	=====	=====	=====	=====
22.670-076	1.50 mm	0.76 mm	0.01 mm	0.001
...
22.670-125	1.50 mm	1.25 mm	0.01 mm	0.001
=====	=====	=====	=====	=====
22.670-130	1.50 mm	1.30 mm	-	0.001
=====	=====	=====	=====	=====
22.670-135	2.00 mm	1.35 mm	0.05 mm	0.001
...
22.670-150	2.00 mm	1.50 mm	0.05 mm	0.001

Micro-forets SPIREC en métal dur.

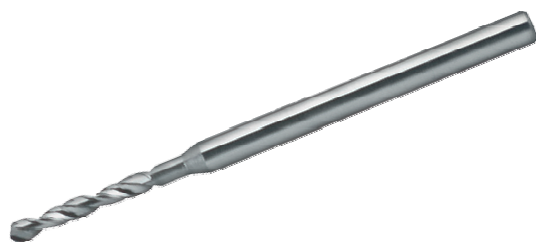

Préciser le Ø lors de votre commande.

Exemples :

MSA22.640-0.05 pour Ø 0.05 mm

MSA22.640-0.80 pour Ø 0.80 mm

MSA22.640-1.51 pour Ø 1.51 mm

MSA	Ø tige	Ø	Progression	Longueur totale	Kg
22.640-0.05	1.00 mm	0.05 mm	0.01 mm	25 mm	0.001
...
22.640-0.79	1.00 mm	0.79 mm	0.01 mm	25 mm	0.001
=====	=====	=====	=====	=====	=====
22.640-0.80	1.50 mm	0.80 mm	0.01 mm	25 mm	0.001
...
22.640-1.50	1.50 mm	1.50 mm	0.01 mm	25 mm	0.001
=====	=====	=====	=====	=====	=====
22.640-1.51	2.00 mm	1.51 mm	0.01 mm	38 mm	0.001
...
22.640-2.00	2.00 mm	2.00 mm	0.01 mm	38 mm	0.001

Forets en acier à outils trempé type 58PM, tige Ø 2.35 mm.



MSA	Ø	Kg	MSA	Ø	Kg
22.610-005	0.50 mm	0.001	22.610-015	1.50 mm	0.001
22.610-006	0.60 mm	0.001	22.610-016	1.60 mm	0.001
22.610-007	0.70 mm	0.001	22.610-017	1.70 mm	0.001
22.610-008	0.80 mm	0.001	22.610-018	1.80 mm	0.001
22.610-009	0.90 mm	0.001	22.610-019	1.90 mm	0.001
22.610-010	1.00 mm	0.001	22.610-020	2.00 mm	0.001
22.610-011	1.10 mm	0.001	22.610-021	2.10 mm	0.001
22.610-012	1.20 mm	0.001	22.610-022	2.20 mm	0.001
22.610-013	1.30 mm	0.001	22.610-023	2.30 mm	0.001
22.610-014	1.40 mm	0.001			

Forets en carbure de tungstène type 58MD, tige Ø 2.35 mm.



MSA	Ø	Kg	MSA	Ø	Kg
22.412-005	0.50 mm	0.001	22.412-015	1.50 mm	0.001
22.412-006	0.60 mm	0.001	22.412-016	1.60 mm	0.001
22.412-007	0.70 mm	0.001	22.412-017	1.70 mm	0.001
22.412-008	0.80 mm	0.001	22.412-018	1.80 mm	0.001
22.412-009	0.90 mm	0.001	22.412-019	1.90 mm	0.001
22.412-010	1.00 mm	0.001	22.412-020	2.00 mm	0.001
22.412-011	1.10 mm	0.001	22.412-021	2.10 mm	0.001
22.412-012	1.20 mm	0.001	22.412-022	2.20 mm	0.001
22.412-013	1.30 mm	0.001	22.412-023	2.30 mm	0.001
22.412-014	1.40 mm	0.001			

Forets diamantés, tige Ø 2.35 mm.



MSA	Ø	Kg
22.650-080	0.80 mm	0.003
22.650-090	0.90 mm	0.003
22.650-100	1.00 mm	0.003
22.650-110	1.10 mm	0.003
22.650-130	1.30 mm	0.003
22.650-140	1.40 mm	0.003
22.650-150	1.50 mm	0.003

Forets en métal dur pour équilibrer les balanciers.

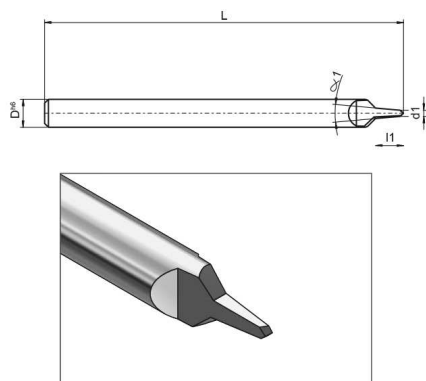

MSA	d1	Dh6	Angle	l1	L	Kg
22.572-017	0.17 mm	1.50 mm	16°	0.6 mm	21 mm	0.001
22.572-018	0.18 mm	1.50 mm	16°	0.6 mm	21 mm	0.001
22.572-019	0.19 mm	1.50 mm	16°	0.6 mm	21 mm	0.001
22.572-020	0.20 mm	1.50 mm	16°	0.6 mm	21 mm	0.001
22.572-021	0.21 mm	1.50 mm	16°	0.6 mm	21 mm	0.001
22.572-022	0.22 mm	1.50 mm	16°	0.6 mm	21 mm	0.001